

# IBM PC Troubleshooting & Repair Guide

Robert C. Brenner



A MICROTREND BOOK



© 1985 by Robert C. Brenner

FIRST EDITION  
SECOND PRINTING — 1985

All rights reserved. No part of this book shall be reproduced, stored in a retrieval system, or transmitted by any means, electronic, mechanical, photocopying, recording, or otherwise, without written permission from the publisher. No patent liability is assumed with respect to the use of the information contained herein. While every precaution has been taken in the preparation of this book, the publisher assumes no responsibility for errors or omissions. Neither is any liability assumed for damages resulting from the use of the information contained herein.

International Standard Book Number: 0-672-22358-9  
Library of Congress Catalog Card Number: 84-52214

Edited by: *Microtrend, Inc.*  
Interior Book Design by Michael Kelly, *Microtrend, Inc.*

*Printed in the United States of America.*



# IBM PC Troubleshooting & Repair Guide

*by*

**Robert C. Brenner**

**Howard W. Sams & Co., Inc.**

A Subsidiary of Macmillan, Inc.

4300 West 62nd Street, Indianapolis, Indiana 46268 U.S.A.

LEARNING RESOURCES & CURRICULUM DEPT.

CALIF. POLY. STATE UNIV. LIBRARY

San Luis Obispo, CA 93407



# Contents

<b>INTRODUCTION</b> .....	13
Why an IBM Repair Guide? .....	13
How To Use This Guide. ....	14
<b>CHAPTER 1 — THE IBM PC DESCRIBED</b> .....	17
The Structure of the PC System .....	18
Inside the System Unit .....	19
Video and Sound .....	22
Mass Storage .....	22
System Configuration .....	23
<b>CHAPTER 2 — IBM PC OPERATIONS</b> .....	25
The Basic Parts of the IBM PC .....	25
Chip Location Scheme .....	27
Central Processing Unit .....	27
Memory Design .....	32
The IBM PC Bus Structure .....	36
Input and Output .....	39
The Power Supply .....	52
How the System Works .....	54
Software Structure .....	55
Summary .....	56

<b>CHAPTER 3— BASIC TROUBLESHOOTING</b> .....	57
Introduction to Troubleshooting .....	57
Component Recognition .....	58
Component Failures .....	63
How Disk Drives Fail .....	63
How Displays Fail .....	64
Repair-Generated Failures .....	64
How To Localize Failures and Make Repairs .....	65
If You Must Use a Service Center .....	72
Safety Precautions During Troubleshooting and Repair .....	72
Summary .....	73
<b>CHAPTER 4— SPECIFIC TROUBLESHOOTING &amp; REPAIR FOR THE IBM PC</b> .....	75
Troubleshooting Index .....	76
Start-up Problems .....	76
Run Problems .....	81
Display Problems .....	95
Monochrome Monitor and Adapter Card .....	95
Color/Graphics Monitor and Adapter Card .....	106
Keyboard Problems .....	121
Other I/O Problems .....	125
Summary .....	134
<b>CHAPTER 5— ROUTINE PREVENTIVE MAINTENANCE</b> .....	135
Contributors to System Failure .....	136
Heat .....	136
Cold .....	127
Dust and Other Particles .....	137
Noise Interference .....	139
Power-Line Problems .....	145
Corrosion .....	148
Magnetism .....	149
Disk Maintenance .....	150
Disk Drive Maintenance .....	152
Using Heat To Spot Potential Troubles .....	158
Display Screens and Health Problems .....	159
Summary .....	160

<b>CHAPTER 6—ADVANCED TROUBLESHOOTING TECHNIQUES</b> .....	161
Tools of the Trade .....	161
Components and How They Fail .....	168
Using Tools To Find Failed Components .....	170
Other Troubleshooting Techniques .....	172
Soldering and Unsoldering .....	175
Circuit Board Repair .....	178
Recommended Troubleshooting and Repair Equipment . . . .	178
Spare Parts .....	178
Summary .....	179
<b>APPENDIX</b> .....	181
IBM PC Data Sheet .....	181
IBM PC Chip Information Chart .....	182
IBM PC System Unit Disassembly Instructions .....	184
IBM PC System Unit Reassembly Instructions .....	185
Keyboard Disassembly and Reassembly Instructions .....	185
Disk Drive Disassembly and Reassembly Instructions .....	186
Replacing Surface-Mounted Components on the System Board .....	186
Useful Recordkeeping Forms .....	186
Routine Preventive Maintenance .....	188
Summary of Cautions and Notes .....	189
ASCII Code Chart .....	190
Hexadecimal-to-Decimal Conversion Chart .....	190
<b>GLOSSARY</b> .....	193
<b>BIBLIOGRAPHY</b> .....	197
<b>INDEX</b> .....	201



# Introduction

---

## WHY AN IBM REPAIR GUIDE?

This book is written and dedicated to all the others who have experienced long, anxious hours waiting for a computer or peripheral device to be fixed and then almost had a coronary when the repair bill was presented.

I am, like yourself, one of the 100 million computer users in this country. When I purchased my first real computer, I was so elated I hardly slept a wink the first night. It wasn't long before my machine was dancing and twirling (figuratively, of course) as it produced tons of code and useful hard-copy reports, articles, and analysis documents.

And then, one day, the dreaded event happened—the computer broke down. I could scarcely contain my frustration. The key, the doggone “A” key stopped working!

My machine was out of warranty. With tenderness, I lifted it and carried it down to my “friendly” computer store.

“My computer is sick.”

“Too bad. What seems to be the problem?”

“Key won't work.”

“Oh? Well, we can take care of that for you.”

“Great! When can I get it back all better?”

“How about a week from Wednesday . . . late afternoon?”

My heart sank. A week from Wednesday? Eight days just to fix a sick “A” key? Reluctantly, I handed over my cherished computer to the service technician. Sadly, I turned and left.

The next eight days were rough—for me *and* my family. From the third day on, one of us called the store's computer service center every day to determine the status of the repair and to try to get the work expedited.

On the appointed day my whole family escorted me to the store. I was like a kid at Christmas. There on the counter was my machine, all neat, clean looking, and fixed. I was back in computer heaven. My friend was coming home.

And then I got the bill. “Wait a minute! This bill says fifty-four dollars and twenty-three cents!”

“Yes, it does.”

“To fix one key?”

“Well, the key actually cost less than five dollars. The rest is labor.”

“But, but . . .” I was stuttering and stammering as I paid the bill, and they escorted me and my computer out to the car.

Although I was indeed happy to have my machine

back, I never forgot that day and that bill. I knew there had to be a less expensive way. Most computers don't often have major failures. Most problems come from the breakdown of simple chips (those little black plastic centipede-looking things) or other easy-to-spot components. And with a little training, just about anyone could make most repairs.

A plan began to develop. Why not repair my own equipment and keep the labor costs for myself? I began to read, study, research, and test various troubleshooting techniques, I spent the next year preparing myself.

And then it happened again. Right in the middle of typing out a college report using my word processor program, the machine suddenly stopped. It quit printing and refused to access the disk where the report was stored.

The report was due the next morning. Here was my first real opportunity to test my knowledge of repairing my computer. To my delight, I was able to troubleshoot and repair the computer in less than an hour. And most of that time was spent running down to the electronics parts store to buy a chip. The total cost for the repair—82 cents plus tax. Probable savings—forty-five dollars. I was convinced. We were all delighted. My research was paying off.

It wasn't long before our friends who also owned computers heard about my success and began calling on me to help fix their machines too. Another idea began to develop. Rather than spend my life running from one friend's repair to another friend's repair (you'll never know how many friends you have until you can fix a computer), I decided to write a book and let everyone save on their own repairs.

This is the result. In the two years it took to complete this guide, each step, each troubleshooting idea was tested and verified.

## HOW TO USE THIS GUIDE

This guide is structured to make it quick and easy for either the novice or the experienced technician to locate and correct most computer failures.

Chapter 1 describes just what constitutes an IBM PC system. The chapter begins with a definition and specification overview, followed by a discussion of system structure.

In Chapter 2, the operation of the IBM PC is explored from both internal and external perspectives.

This chapter describes what happens inside the machine and explains what events you should observe as the system powers up. Each of the major subsystems of an IBM PC is discussed, and numerous drawings are included to help you understand.

The third chapter introduces troubleshooting and repair. In easy-to-understand terms, it leads you step by step through the diagnostic techniques—called troubleshooting—for microcomputer hardware. Chapter 3 covers repair methods and numerous useful hints taught to the best service technicians.

Chapter 4 describes specific hardware malfunctions (failures) that can happen to the IBM PC. The main focus of the book, IBM-specific failure diagnosis and repair, begins in this chapter. The chapter starts with a trouble-symptom index table that guides you quickly to the page that treats a specific problem. Malfunctions are organized by computer subsystem. Each type of failure is analyzed to the chip level with ample drawings, including a picture layout of the board on which the failure is most probably located, with chips highlighted for easy identification.

A good repair guide should not just help locate and correct computer failures; it should also provide guidance in preventing further failures. Chapter 5 provides valuable periodic preventive maintenance suggestions to help maintain a healthy system. This chapter covers such subjects as maintenance of disks and disk drives, electrical and magnetic interference, and recommended cleaning techniques. The chapter also includes a list of preventive maintenance actions you can use to keep the system in peak operating condition and to extend its "on-line" life.

By the time you've mastered Chapters 1 through 5, you should be able to troubleshoot and repair 95 percent of all IBM PC computer failures. Chapter 6 was written for those who wish to go after the remaining 5 percent of malfunctions. This chapter describes the tools of the repair technician's trade—logic probes, logic pulsers, current tracers, oscilloscopes, logic analyzers, and signature analyzers. The chapter even provides guidance in developing some of your own diagnostic tools, both hardware and software.

The Appendix provides a wealth of backup information. It includes step-by-step disassembly and reassembly instructions, conversion tables, specification data sheets, and component-marking conventions. In the Appendix, you will also find forms useful for recording original system configuration, maintenance, and configuration changes, as well as a preventive-maintenance schedule.

A reference section, a glossary, and a thorough index complete the guide.

This book is a detailed troubleshooting and repair document. It is not a treatise on basic computer theory or a highly technical discussion of chip operation, registers, busses, and logic gates. It is an all "meat and potatoes" manual to enable the computer user to

repair his or her own machine in those 95 percent of circumstances where knowledge and a good reference are enough to find and repair a failure.

Using this guide, you should be able to isolate and correct most IBM failures. It has brought me much success in my own troubleshooting, and I trust it will do the same for you.

Robert Brenner



# The IBM PC Described

---

**C**hapter 1 presents a basic overview of the IBM Personal Computer (PC) as a prelude to learning how to troubleshoot and repair this machine. The intent of this chapter is to familiarize novices with the computer and to provide a helpful review for more experienced users.

The introduction of the IBM PC on August 12, 1981 signified a major change in the corporate policy of the giant IBM company. And their entry into the small computer marketplace has had an impact on every microcomputer manufacturer in the world. When IBM introduced the PC, the Fortune 500 companies became aware of the professional capabilities of personal computers. Although microcomputers had been successfully meeting the needs of small businesses for several years, it was not until "Big Blue" (IBM) began actively marketing microcomputers that the personal computer leaped out of the hobby arena and became an accepted fact in modern business.

With the introduction of the PC, IBM adopted some major policy changes. Previously, the corporation had manufactured all the products it sold. IBM had had no interest in third-party components, modules, or equipment. However, early in the design phase of the PC, IBM recognized that third-party hardware would be vital in bringing the PC to market in the highly com-

petitive microcomputer industry. A key ingredient to the success of the PC would be its ability to adapt to established industry standards and its compatibility with products already on the market.

The operating system software for the PC was developed outside IBM. Tim Patterson of Microsoft and Seattle Computer Company wrote PC-DOS between the spring of 1980 and the summer of 1981. He was also the originator of the 86-DOS that became Microsoft's MS-DOS. Other operating systems currently used on the IBM PC include CP/M-86 from Digital Research and UCSD p-System from Softech Microsystems.

IBM's list of high-level language and applications software sources includes Digital Research, Microsoft, Peachtree Software, Personal Software, Softech Microsystems, and Information Unlimited Software. The decision to use established outside software suppliers was a major break in IBM tradition.

The disk drives used in the PC were built by companies such as Tandon Magnetics. The dot-matrix printer sporting that IBM logo was manufactured by Epson. Even the display monitors were manufactured by other companies.

To get the PC quickly into the hands of a vast market of users, IBM opened up its technical knowledge base. It provided full technical specifications,

including the source code for the operating system, to encourage peripheral hardware and software developments by entrepreneurial computer enthusiasts all over the United States. Just as Apple had, IBM found this strategy very successful. In less than two years, over 600 outside vendors were marketing more than 2,000 different products for the IBM PC.

The PC's modular construction with five expansion slots for add-on peripherals provides flexibility. The IBM PC XT has eight built-in expansion slots. IBM PC users can choose from a wide selection of enhancements, including color and monochrome (single-color) displays, additional floppy disk drives, hard disks, communications adapters for modem (modulator-demodulator) use, game and joystick adapters, expanded memory boards, plotters, and a wide range of printers.

## THE STRUCTURE OF THE PC SYSTEM

A typical PC system includes the system unit that houses the main electronics of the computer, two disk drives, the full-size keyboard, a video display device, and a printer. Fig. 1-1 shows this system (without the printer).

### The System Unit

The system unit is 5.5 inches high, 19.6 inches wide, and 16.1 inches deep. It weighs 28 pounds with two disk drives. Two standard-height, double-density



**Fig. 1-1.** The IBM Personal Computer (PC).

disk drives are mounted in the system unit, providing 320 kilobytes (K) of mass-storage disk capacity for programs and data. Earlier models of the PC came with 160K single-density drives.

Inside the system unit are the primary components that make the PC function—the switching power supply, the main logic board (called the system board, or motherboard) with its memory chips, and five input/output expansion slots.

### The Keyboard

The 20-by-8-by-2.5-inch detachable typewriter keyboard shown in Fig. 1-2 has 83 keys that can generate all 128 characters in ASCII (the American Standard Code for Information Interchange), as well as special symbols and graphic shapes. The keyboard can provide a total of 256 characters, shapes, and symbols.



**Fig. 1-2.** The IBM PC detachable keyboard.

On the right side of the keyboard is a numeric keypad; some of its keys double as cursor-control keys. On the left side of the board are 10 programmable function keys that can be used to execute selected programs or to initiate special routines (subprograms). The functions of these keys can be programmed by the software designer. In IBM BASIC the function keys allow commands such as LIST and RUN to be entered with a single keystroke.

In addition to Shift and Up, Down, Right, and Left arrow keys, the keyboard has a number of special keys such as Caps Lock, Number Lock, Scroll Lock, Backspace, Enter, Home, Page Down, Page Up, End, Delete, Insert, Print Screen, Tab, Control, and Alternate. The function of each key is described in the *IBM Guide to Operations* manual. Several of these keys can be used together to perform special functions. For example, holding down the Ctrl and Alt keys and then pressing the Del key will cause a system reset, or warm boot, to occur. Other combinations of key actions stop the program that is being executed in the machine,

move the cursor to the next or previous word, or clear the screen.

Holding any key down for more than a half second causes its character to repeat automatically. All 83 keys have this automatic repeat feature. In addition, a storage space is built into the keyboard to let you type ahead. It will remember up to 10 characters, letting you type at rapid speed without getting ahead of the computer.

The IBM PC keyboard was structured after a profile developed in 1980 by West Germany's Deutsche Industrie Normenausschuss (DIN). The DIN specification sets keyboard height (profile) for angles between 0 and 10 degrees from horizontal and also determines how far the keys can be depressed (key travel distance). It requires the use of sculptured keytops and tactile key action. The placement of the backslash key between the left Shift and Z keys is also a result of the DIN specification. This layout has become quite natural to Europeans, and most users become accustomed to it after just a few hours of typing operation.

The keys are "dished" slightly (they have concave top surfaces). This sculpted shape gives each key a comfortable feel. The keys also provide a tactile feedback, or snap-over sensation, when depressed to the operating point. An audible contact click also provides positive feedback that key action has been completed.

Unlike many other microcomputer keyboards, the IBM PC keyboard contains electronic circuits that enhance key operation and permit keys to be redefined. This redefinition potential provides increased programming flexibility.

Two plastic feet built into the keyboard housing allow it to be tilted in two positions for comfortable use. A horizontal plastic ridge located just above the top row of keys can be used to prop up a book or report between the keyboard and the display screen. It also was designed to hold templates for special applications software across the top of the keyboard. The keyboard connects to the rear of the system unit by means of a 6-foot coiled cable.

On the right side of the system unit, toward the back, is the ON/OFF power switch.

## Display Unit and Printer

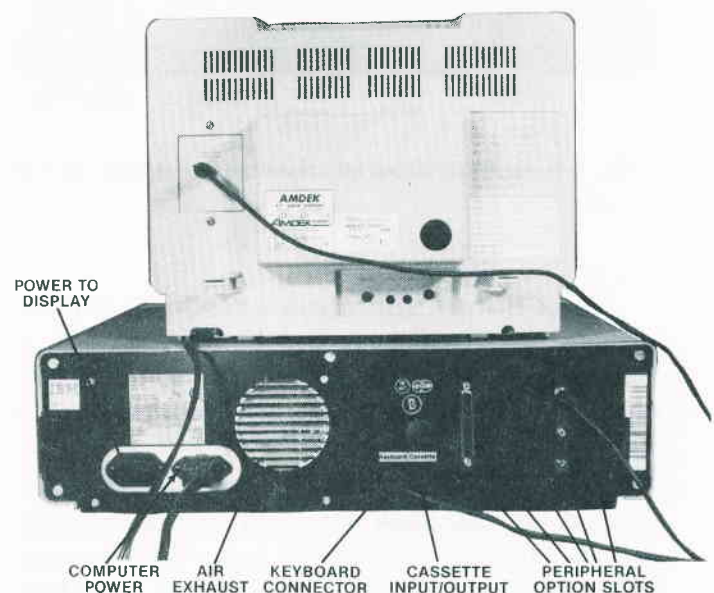
Two other units make the computer a complete system—a display unit and a printer. Both of these devices are considered options by IBM. IBM sells both a monochrome monitor and a color monitor. In addition, when an interface called a radio frequency (RF) modulator is connected to the video adapter card inserted into one of the input/output slots, a standard

television can be connected to the computer. Monitors connect through the rear of the system unit to the appropriate adapter cards. Although this guide doesn't cover internal repair of monitors, it does address a number of display problems that are easy to correct.

A number of printers can interface with the IBM PC. IBM sells a dot-matrix printer manufactured by Epson as an IBM-recommended option.

## Connections

Fig. 1-3 shows the connections at the back of your IBM PC computer. From left to right, notice the female connector to provide power to the IBM monochrome display; the male connector to which you connect the power cord that plugs into a wall socket or power strip; a round, slotted opening for the fan air exhaust; a 5-pin circular connector for the keyboard cable; a 5-pin circular connector for the cassette input/output port; and five slots for connecting displays, disk drives, printers, plotters, and other peripherals to the system unit.

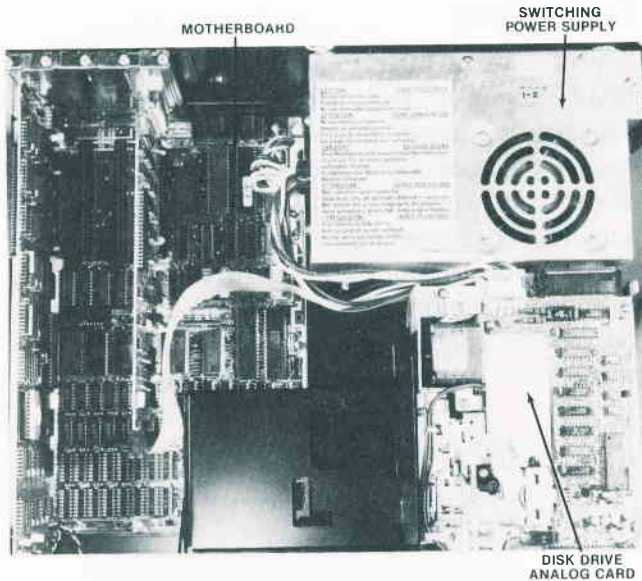


**Fig. 1-3.** The connections found on the back of the PC system unit.

## INSIDE THE SYSTEM UNIT

Facing the rear of the IBM PC's system unit, you'll see either three or five screws holding the cover housing on the system unit electronics chassis. Make sure the power to your IBM PC is turned off. Then use a nut-driver or a flat-head screwdriver to remove the five

screws (three on earlier machines) from the back of the computer (see the Appendix). Turn the unit around so the disk drive doors face you, and carefully slide the housing forward, tilting it as it is removed. Look inside and compare what you see with the components identified in Fig. 1-4.



**Fig. 1-4.** Looking down into the system unit from the top.

Notice that the system unit is composed of three subunits—a printed-circuit board on the left side, a power supply in a metal shield at the right rear, and one or two disk drives in their metal housings.

## The Motherboard

That big, flat, black thing with the copper traces and all those tiny components is the printed-circuit board, *main system board*, or *motherboard*, of the IBM PC. Mounted on this board are tiny, black integrated circuits (ICs, or *chips*) that make up the most important part of the machine—the 8088 *central processing unit* (CPU), *microprocessor*, or simply *processor*, with its input/output (I/O) unit, memory, and a host of other chips that help the CPU move information around, into, and out of the motherboard.

The IBM PC has 99 chips on its motherboard. Half again as many chips can be found on the adapter boards required to provide display and disk drive capability.

## Expansion Slots

Looking toward the rear of the chassis, you'll see five 62-pin *connector slots*. These slots are used to connect peripheral devices to the motherboard. Each slot provides access to the most important signals in the computer. The PC was designed with an open architecture. It's sold unbundled (in parts), so the user must buy each unit separately and then connect these units to form a completed system. Nothing but the system unit and keyboard is included in the basic PC configuration. Everything else must be added on, including the display, the disk drives, and the printer. Each peripheral connects to the computer by means of an *adapter card*. The PC's design provides for integration flexibility, but the expansion slots fill up quickly. The slots are numbered J1 (slot 1) to J5 (slot 5) from left to right.

Any slot can be used for any type of adapter card, but IBM has recommended that slot 2 be used for the display adapter, because it is the longest card that can fit into a slot, and slot 2 (on early PCs) has a special plastic guide to prevent the long card from wobbling in the socket. A typical configuration with a monochrome display unit is connected as shown in Table 1-1.

**Table 1-1. Typical slot configuration**

Slot	Interface Installed
1	Disk controller interface board
2	Monochrome adapter and parallel printer port
3	Asynchronous/synchronous communications card

The expansion slots can be used to connect many other devices, including modems, which allow you to send and receive information through your phone lines; voice-recognition and voice-generation boards; elaborate displays; and even additional printers. It is possible to connect both a dot-matrix and a daisy-wheel printer to the IBM PC concurrently.

Since the IBM PC can address up to 1 megabyte of memory, additional memory cards can be installed in the expansion slots to increase the available memory to over 600K.

Up to four disk drives (two internal and two external) can be connected to the IBM PC using a disk controller card interface. With third-party hardware, the PC's disk drive capability can be expanded to six double-sided, double-density drives.

You'll find eight sizes of chips on your IBM PC motherboard—8-pin, 14-pin, 16-pin, 18-pin, 20-pin, 24-pin, 28-pin, and 40-pin.

## Chips

That big, long chip sitting just below the cassette I/O port is the brain of your IBM PC—the Intel 8088 processor, or central processing unit. Everything that happens inside your computer is controlled by this chip. The 8088 moves data and instructions on an 8-bit data bus. It operates as a 16-bit machine internally, using the same 16-bit instruction set as the Intel 8086 microprocessor.

Next to the 8088 processor is an empty slot for connecting an 8087 numeric data processor chip. The 8087 is a high-speed, two-channel I/O controller and coprocessor that extends the 8088 instruction set to include arithmetic and logical operations. The 8087 doesn't change the way the system operates, yet it can perform some mathematical functions many times faster than the 8088 CPU. With the addition of an 8087, the PC becomes an impressive engineering and scientific tool.

There are some other special chips on your IBM's main board. Just to the left of the 8088 CPU is the 8259 *interrupt controller*. The IBM PC is called an "interrupt-driven machine," because all I/O devices, including the keyboard, the display, and the printer, communicate with the CPU by causing an interrupt signal to occur. This interrupt signal makes the CPU stop, look, and listen to whatever is trying to send or get information. The 8259 is the device that hears the request to communicate from the peripherals and generates the interrupt signal that is sent to the CPU.

At the far right on the second row of chips is the 8284 *clock generator*. This socketed chip connects directly to the 14.31818 MHz crystal and develops the various clock signals used within the computer. When power is first turned on, this chip receives a special signal from the power supply indicating that power levels are normal. The 8284 uses this signal to develop a RESET pulse to start the CPU operating.

## ROM

On the fourth row of chips, and below the expansion slots, is an empty socket and then a row of five large chips. These five devices make up the *read-only memory* (ROM) of the computer. The five ROM chips have special programs permanently stored in them. This software that is stored in hardware is called *firmware*. ROM can only be read from. You can't store any

of your programs in a ROM chip. Its purpose is to hold programs placed there by the manufacturer. These programs are available as soon as you turn power on.

One ROM chip holds the ROM *basic input/output system* (BIOS), a set of programs that control information transfer between the CPU and the input/output devices. The BIOS provides control for all devices except the disk drives. Included in this ROM is a self-test program that checks out the PC when power is first turned on.

The other four ROM chips hold the version of the high-level language BASIC that IBM calls *Cassette BASIC*. Cassette BASIC is a large program, but it was included in the PC design because BASIC is a popular language for writing your own programs.

The empty socket was originally planned to hold another ROM BASIC chip. But in the final design, Cassette BASIC fit into four chips.

To the right of the last ROM chip is the 8253 *programmable interval timer* (PIT). This device develops a special time-interrupt signal. It also develops a pulse to operate the speaker.

Next to the 8253 PIT is the 8237 *direct memory access* (DMA) *controller*. This chip controls the movement of large blocks of information into and out of the computer. It is used primarily to move data between the mass storage memory (disk drives) and the internal memory.

To the right of the 8237 DMA controller is the 8255 *programmable peripheral interface* (PPI) chip. This device has several ports through which external devices can communicate with the CPU. The ports can be configured by sending software commands to the programmable chip.

## RAM

Sitting in four neat rows of nine chips each at the lower right of the system board is the IBM PC's *random-access memory* (RAM). This is the scratch pad or blackboard of your PC's memory. These chips can be read from or written to. Each of these chips is a 16K-by-1-bit or 64K-by-1-bit RAM, depending on the type of motherboard installed (16K to 64K in four rows, or 64K to 256K in four rows). Eight of these chips make up the 8-bit data word memory. The ninth chip in the row is used to confirm the accuracy of the data stored in the other eight. The eight data word chips temporarily store programs that you write or load from your disks. Remember to save your work before you turn your IBM PC off, because once power is turned off, any information in RAM is lost.

On the version of the system board that uses 16K-by-1-bit chips, all four rows of RAM sockets can be filled, bringing the total of on-board RAM to 64K. The newer version of the system board uses 64K-by-1-bit chips. This board is fully populated, to achieve a total of 256K of on-board RAM.

Additional RAM can be added by inserting memory cards into the expansion sockets. With system board and expansion sockets, the PC has a RAM capacity of 640K.

## The Power Supply

Inside the chassis, to the right of the system board, is a *switching power supply*, housed in a big, shiny metal box. This subunit faithfully takes in electrical power from the cord you plug into the wall socket and converts it to the voltages necessary to make your computer system function properly. The switching power supply is very reliable. This guide doesn't discuss repairing the power supply, because extensive training is required to conduct repairs in high-voltage circuits. The electrical cord plugs into the back of this power supply just to the left of the ON/OFF rocker switch. A special jack at the rear of the power supply accepts the power plug for the IBM display unit.

## VIDEO AND SOUND

The video of the IBM PC also has certain advantages over those of other microcomputer systems on the market. Two display adapters are available; a monochrome display adapter that supports text, and a color/graphics adapter that supports color graphics or text.

Using the *monochrome adapter*, the machine can generate 25 rows of 80 characters each. Characters can be displayed in white on a black background (green on black with the IBM monochrome monitor), black on a white background (or black on green), blinking, in high intensity, or underlined. The monochrome adapter card includes an interface connection for the IBM 80-character-per-second dot-matrix printer.

The *color/graphics adapter* card provides the capability to display two types of text and three types of graphics. This adapter also supports a light pen.

The *color/graphics card's* first text format displays 25 rows of 40 characters each. This format is suitable for standard monitors and televisions. But you'll need another type of adapter (RF modulator) connected to the video output of the color/graphics adapter in order

to use your television set.

The second text format provides 25 rows of 80 characters each. The characters can be displayed on an RGB (red-green-blue) monitor for sharp, high-quality presentation.

Three types of color graphics are possible: only two are supported by the ROM.

*Low-resolution graphics* lets you display 100 rows of 160 pixels (picture elements), or dots, in any of the 16 standard colors described in Table 1-2.

**Table 1-2. Colors available in low-resolution graphics mode**

Black	Blue	Green	Cyan
Red	Magenta	Brown	Light Gray
Dark Gray	Light Blue	Light Green	Light Cyan
Light Red	Light Magenta	Yellow	White

Low-resolution graphics mode can be used only with special programs that directly address the 6845 CRT controller device on the adapter card.

*Medium-resolution graphics* mode allows display of 200 rows of 320 pixels, in any of four possible colors. Additional colors can be generated by juxtaposing dots of different colors.

In *high-resolution graphics* the display, 200 rows of 640 pixels, is limited to black and white. Text can be placed within the graphics.

Inside the chassis at the left side of the system board is a small (2-inch) 8-ohm speaker that can produce all sorts of sounds, including the familiar beep, arcade sounds, music, and even crude speech.

## MASS STORAGE

At the back of the computer is a connection for a cassette interface. When the first microcomputer was built, disk drives were very expensive, so the first microcomputer users were given the option of using standard audio cassette recorders as mass storage devices.

### Cassette Storage

Using cassette tapes is an inexpensive way to provide mass storage for your programs, but saving or loading these programs with a cassette tape recorder is slow and frustrating because of the rewinding and the close attention to the tape counter required to locate the beginnings and endings of files. Most IBM PC users

who start out with these recorders soon shift to a floppy disk drive storage device for its speed, reliability, and simplicity of operation, and because many more programs are available on disk than on tape.

One reason you might want to consider using cassettes as a mass storage medium is for archive, or backup, storage. Many more files or pages of information can be stored on a good audio cassette tape than can be stored on a floppy disk. In fact, one type of archive storage for hard disks is a cassette video tape. Corvus, a hard disk manufacturer, uses a system called the Mirror to back up hard disk files on video tape.

## Disk Drives

Disk drives connect to the PC via a special adapter card (usually plugged into expansion slot 5 at J5). Your disk drive lets you store and retrieve information on flexible magnetic disks called minidiskettes, or floppy disks. Disk drives are an important part of your IBM PC system. Chapter 4, "IBM PC-Specific Troubleshooting and Repair," and Chapter 5, "Routine Preventive Maintenance," contain extensive information on disk drives.

## SYSTEM CONFIGURATION

A "basic" IBM PC system is shown in Fig. 1-5. With the built-in speaker, this is a minimal system configuration for the IBM PC. Without the display, keyboard, or cassette recorder/player, your computer would be so limited that it couldn't really be called a system.

In Fig. 1-6, you see the "standard" IBM PC configuration. The cassette recorder/player has been replaced with a floppy disk drive, and a printer has been added to provide hard copy, or printed output. The memory has been expanded to 128K, the standard memory size for current software packages.

Small business users generally configure a system as shown in Fig. 1-7. Connecting an optional memory expansion card brings the total RAM to 640K. The addition of a CP/M card allows you to use programs written for the popular CP/M operating system. The two disk drives let you use larger software programs that actually need more than one disk drive to run.

The IBM PC's flexibility is illustrated in Fig. 1-8. You can connect almost any electrically controlled equipment to your computer.

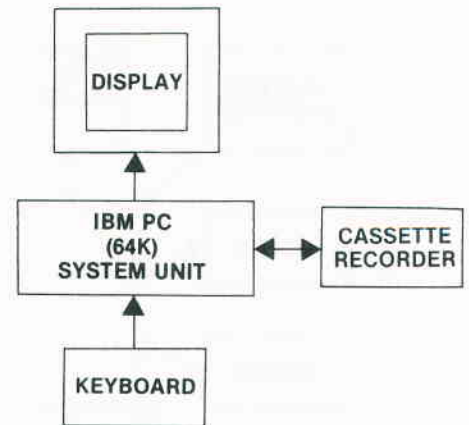


Fig. 1-5. The basic IBM PC system.

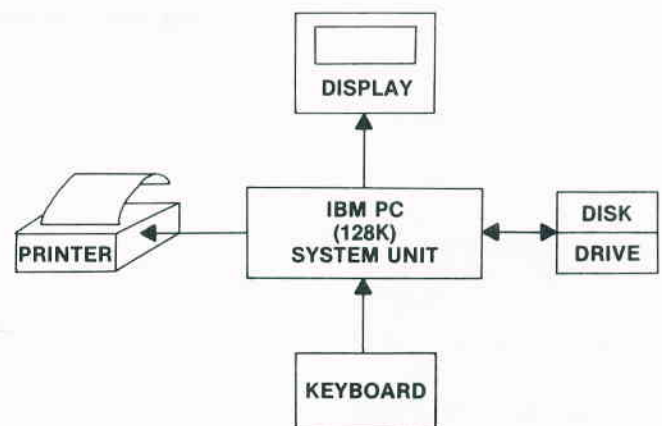


Fig. 1-6. The standard IBM PC configuration.

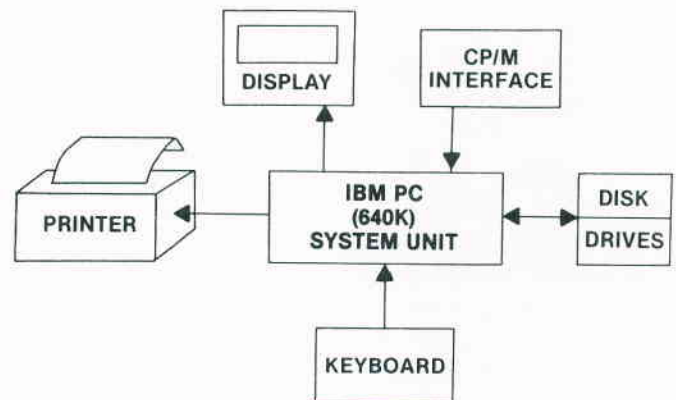
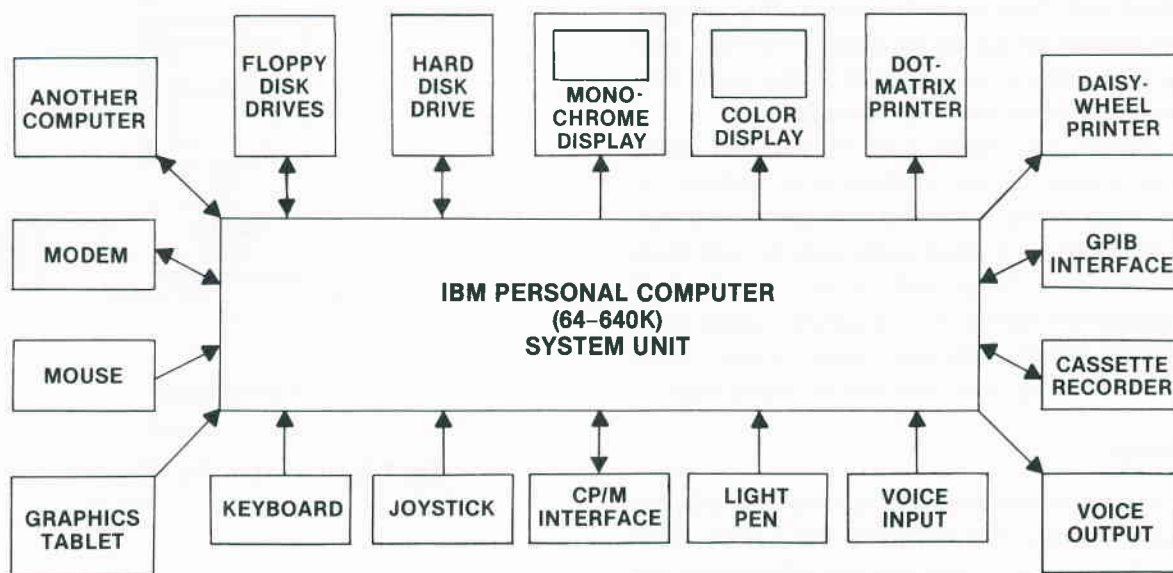


Fig. 1-7. The typical small business IBM PC system.



**Fig. 1-8.** The flexibility of the IBM PC.

# IBM PC Operations

In Chapter 1, you read a descriptive overview of the IBM PC. This chapter explores how the IBM PC works. Some of the material in this chapter is quite technical. You won't need to know the technical details of how PC components work in order to troubleshoot and repair your system. However, this information is included for those readers with a more technical interest.

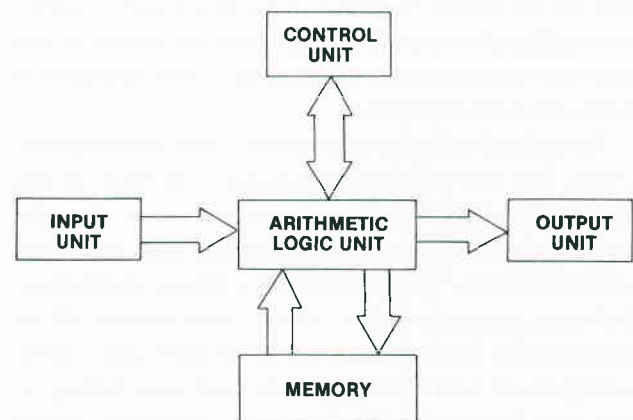
## THE BASIC PARTS OF THE IBM PC

Whether it's a tiny single-chip micro, an IBM PC, or a room-size mainframe, every computer has five basic parts:

- An arithmetic logic unit
- A memory unit
- An input unit
- An output unit
- A control unit

These parts are associated as shown in Fig. 2-1.

Math and number crunching occur in the **arithmetic logic unit** (ALU). All the adding, subtracting, multiplying, dividing, comparing, and other manipulations are done by the ALU.



**Fig. 2-1.** The five basic parts of the IBM PC.

The **memory unit** is used to store programs, calculations, and results. As shown in Fig. 2-2, this unit includes two types of memory—RAM (random-access memory), which can be read from and written to, and ROM (read-only memory), which can be read from but not written to. RAM is sometimes called *main memory*.

When you turn off power to your IBM PC, whatever you had stored in RAM is lost unless you have first saved it on a disk. The program in ROM is placed there by IBM during manufacturing, and it remains even

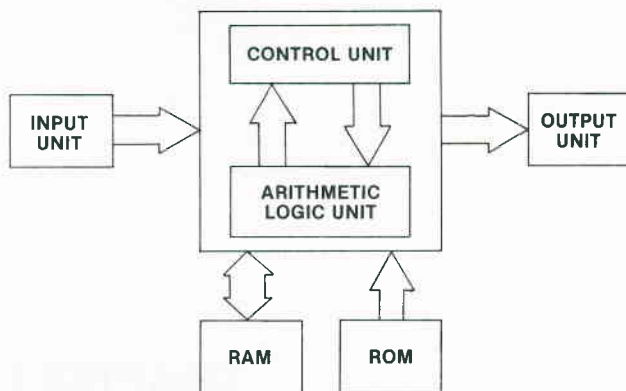


Fig. 2-2. The memory is composed of RAM and ROM.

when the power is off. Since the ROM program (software) is in a device (hardware), we call it *firmware*.

The **input unit** lets you enter information into the computer. It is a way for you to “talk” to your PC. This communication is called the “man-to-machine” interface. You can communicate with your computer through your keyboard, a light pen that reacts as you touch a place on the screen, a special pen and a graphics tablet, a mouse that moves your cursor about the screen as you move the mouse on your desktop, or a voice-recognition board and a microphone.

An **output unit** gets information from the computer to you. We call this machine-to-man interface. It lets the IBM PC “talk” to you. A monochrome or color monitor screen is the most commonly used machine-to-man interface. You can also use a printer to produce hard copy, or paper output. Other ways for your PC to communicate include turning on motors and lights, making music and arcade sounds, and even talking in your own language with a speech synthesizer board and a speaker.

Some computer devices are for both input and output. One input/output (I/O) device includes a form of memory external to the computer—*mass storage*. You save your programs to mass storage and retrieve them as needed. Mass storage includes floppy disks, cassette tapes, hard disks, and the recently developed optical disks. Another I/O device is the modem (modulator-demodulator), which you use to send or receive information through your telephone line. Modems can connect your computer to any other computer in the country (if not the world) using either dedicated telephone lines or the standard four-wire telephone lines of your home or office.

Input/output devices are called peripherals. Some

can be built into your computer—for instance, your speaker. Others are connected to your IBM PC through printed-circuit cards called interfaces, or adapters, that plug into slots, those long sockets on your PC system board, or motherboard. A large number and variety of interface cards are available for the PC. Some cards provide interface to the devices needed to make your system function—the display monitor, the disk drives, and the printer. Only five expansion slots are available in the PC. This limits the configuration that can be developed. The number of expansion slots can be increased by adding an expansion chassis to the computer. This will use only one slot in the main system unit, but will add eight slots of expansion capability.

Everything your PC does is directed by the **control unit**. This unit interprets computer instructions and initiates the signals that cause the computer’s circuits to do certain tasks.

The control unit and the arithmetic logic unit are combined into a single chip called the *central processing unit*, or CPU. As shown in Fig. 2-3, the CPU on your IBM PC motherboard is an 8088 microprocessor. This microprocessor uses the same instruction set as the Intel 8086, and handles instructions in 16-bit sets, although the data output word is 8 bits wide. The 8088 is therefore, a 16-bit instruction, 8-bit data microprocessor. Its address word width distinguishes it from other 8- or 16-bit microprocessors. The 8088 uses 20-bit address words to access memory. This means that it can directly address over 1 million memory locations (1,048,576 to be exact).

Your PC’s 8088 CPU looks into memory, fetches an instruction from that location, interprets the instruction, performs the actions the instruction requires (e.g., adding two numbers), and then moves on to process the next instruction. Unless the next instruction directs

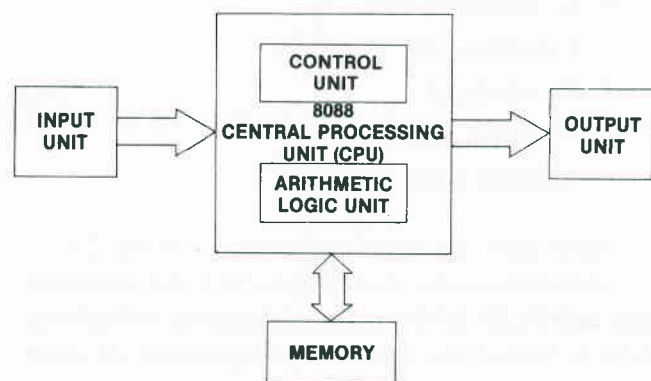


Fig. 2-3. The control unit and arithmetic unit together form the central processing unit (CPU).

the 8088 to a particular memory location to carry out the instruction stored there, the CPU will move from one instruction to the next instruction in sequential memory locations (one step after the other). Perhaps the most important difference between your stepping through a program (sequence of instructions) and your PC's doing the stepping is that the IBM can handle about a million of these steps each second.

## CHIP LOCATION SCHEME

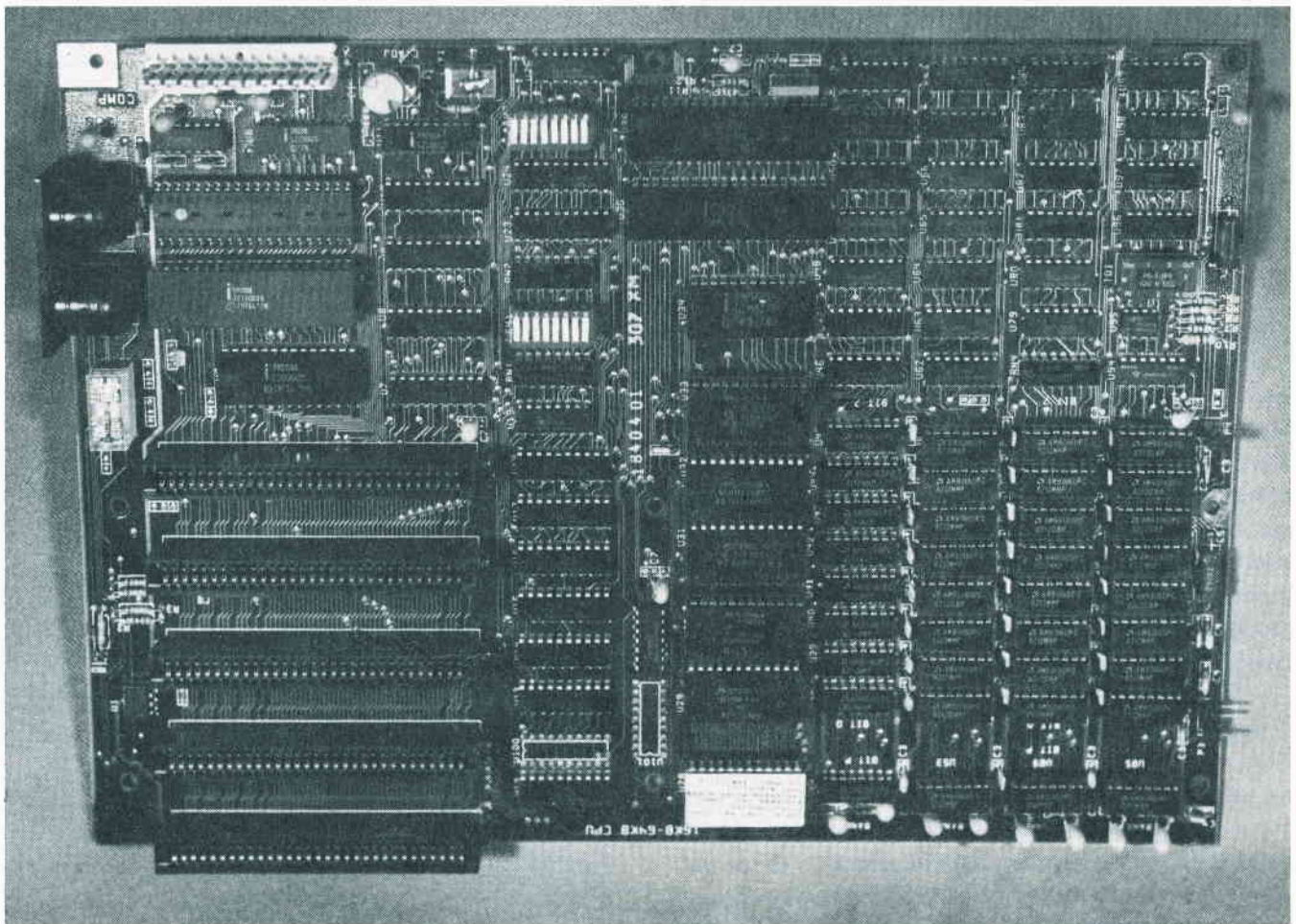
When IBM designed the new PC motherboard, they took a number of steps to make the board easy to install and easy to troubleshoot. The motherboard was divided into five functional areas—the processor subsystem and its supporting chips, the ROM subsystem, the RAM subsystem, the integrated I/O adapters, and the I/O channel, which includes the expansion slots. As shown in Fig. 2-4, IBM PC designers laid out the board with most of the chips mounted vertically with pin 1 of

each chip at the top left corner. They also marked each component's identification code on the printed-circuit board (system board) and numbered the chip locations in increasing order from left to right, top to bottom. This allows you to quickly locate any IC or chip on the board. Fig. 2-4 shows the original (16K-64K) PC system board. In Chapter 3 (Fig. 3-2) you'll find a photograph of the newer (64K-256K) PC system board.

In the pages that follow, all system board chips being discussed will be identified by the chip type (e.g., 74LS125), name (e.g., quad tri-state buffer) and board designation or chip location (e.g., U80). The chip types and location numbers are shown in Fig. 2-5. In addition, a list of all chips used in your IBM PC can be found in the Appendix.

## CENTRAL PROCESSING UNIT

Look at the motherboard. Reopen the machine if necessary (see the Appendix for disassembly instructions).



**Fig. 2-4.** The IBM PC system board (motherboard).

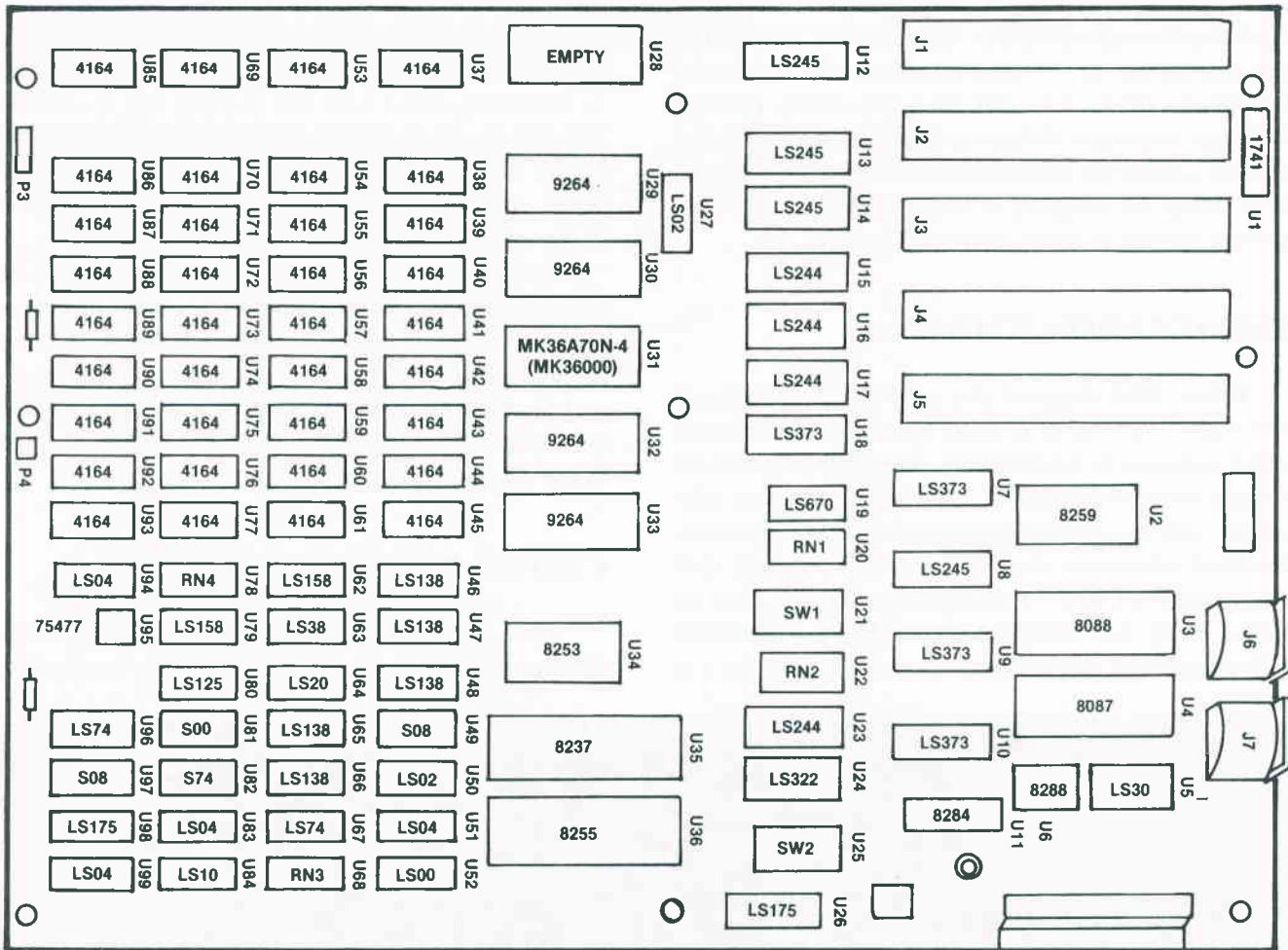


Fig. 2-5. The system board chip layout.

As indicated earlier, the 8088 CPU (shown in Fig. 2-6) is an 8-bit version of Intel's 16-bit 8086 processor. The size is determined by the number of bits in the data word. The 8088 uses the same instruction set as the 8086, so it supports 16-bit operations, including multiply and divide. With 20 address lines (20 bits in the address word), the 8088 can address over a million memory locations. It can also operate in maximum mode with a coprocessor, the 8087 numeric data processor, which greatly increases computational speed.

The 8088 operates at a 4.77 MHz. Since, internally, it handles words up to 16 bits long only, the CPU expands its internal address word to 20 bits at its output by using a segmentation scheme. Memory addresses are logically subdivided into special segments of 64K bytes each. These segments can be allocated to special segment registers within the 8088. Bytes within a segment are addressed using a 16-bit offset address. The 20-bit physical address is constructed inside the 8088

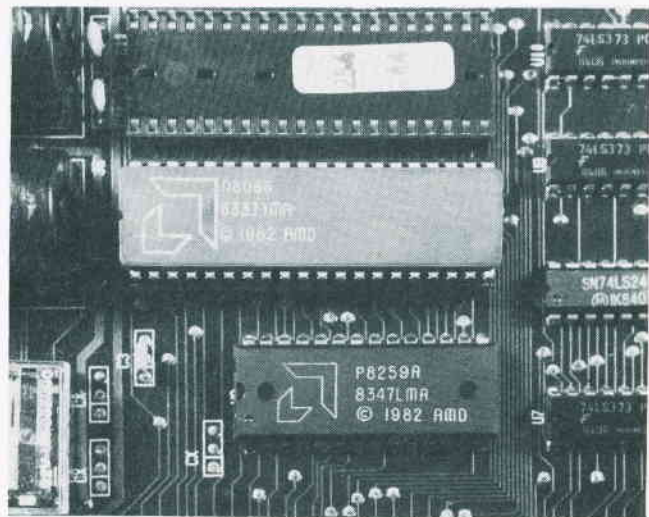
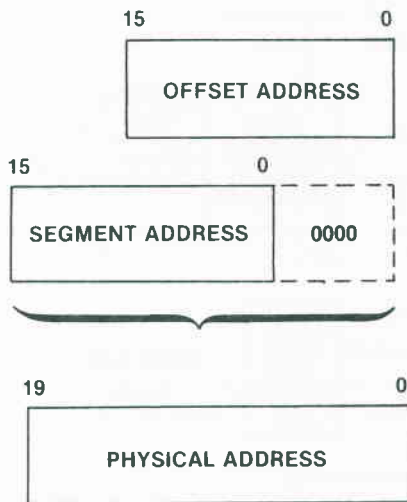


Fig. 2-6. The 8088 CPU.

by adding the 16-bit offset address to the 16-bit segment address with the segment address shifted left by one hexadecimal value as shown in Fig. 2-7. Once the offset and segment addresses are summed, the physical address is available on the 20 address pins of the chip.



**Fig. 2-7.** The 20-bit address word consists of a segment address and an offset address, combined to form a physical address.

Some programs can be loaded or manipulated within a single segment and do not use the segment registers. These programs are said to be *dynamically relocatable*. The high-level language BASIC can address up to 64K only. Therefore, most programs written in BASIC are dynamically relocatable.

The 8088 uses 20 address lines to specify a location in its 1,048,576-byte (1 megabyte) range. These signal lines are designated AD0–AD7 and A8–A19. The first eight lines (AD0–AD7) are dual purpose. They are used for both address and data transfer. As shown in Fig. 2-8, the address latch enable (ALE) signal from the 8288 bus controller (U6) to the three 74LS373 address latches (U7, U9, and U10) controls the multiplexing of address information out of the CPU. When the information on AD0–AD7 is part of an address, the 8088 generates a special code on the S0–S2 lines to U6, causing the 8088 to let the ALE latch the 8 address bits into U7. After the address is latched, lines AD0–AD7 are available for two-way data transfer. Data transfer is controlled by the data enable (DEN) signal from U6. The data transmit/receive (DT/R) signal from U6 is used to let the 74LS245 data line buffer (U8) write (transmit) or read (receive) on the data bus.

CPU signals S0–S2 are also used to tell the bus controller (U6) what devices the CPU wants to communicate with. The bus controller then generates the appropriate memory read (MEMR/), memory write (MEMW/), I/O read (IOR/), or I/O write (IOW/) signals. For I/O read and write functions, only address lines AD0–AD7 and A8–A15 are used. Therefore, with 16 address lines, a total of 65,536 (64K) addresses are available for I/O.

### Special System Support Chips

The 8088 CPU on the system board is configured with special support chips as shown in Fig. 2-8. These chips work hand in hand with the 8088 CPU to make the computer function as a complete unit. These chips include the 8284 clock generator (U11), the 8259 programmable interrupt controller (U2), an 8255 programmable peripheral interface (U36) (not shown), and the 8253 programmable interval timer (U34) (Fig. 2-9). Each of these chips will be addressed in the next several paragraphs.

#### The 8284 Clock Generator

Information processing is possible in those tiny chips on the system board because the clock generator (U11) continuously sends out several clock signals that pulse throughout your IBM PC. As shown in Fig. 2-9, a crystal oscillator (Y1) connects to the 8284 clock generator. When the power is turned on, or when you press the Ctrl-Alt-Del key combination, the POWER GOOD signal reaches U11 from the power supply and a RESET signal is produced. This signal initializes storage registers within the 8088 and causes it to start operation at address 0FF-FH (H means hexadecimal). This address is in ROM. The clock generator (U11) also produces a READY signal to let the CPU know that the rest of the circuitry is clear to receive or send information. If the memory or an I/O device cannot keep up with the CPU, the READY line goes to a logic LOW, causing the 8088 to stop processing until the rest of the system is ready to proceed. The 8284 clock generator then brings the READY line to a logic HIGH again.

When the power is turned on, the oscillator starts pulsing at a 14.31818 MHz rate. This master oscillator signal is used to develop all other clock signals on the motherboard, as shown in Fig. 2-9.

The clock pulses are divided by 3 in the 8284 clock generator (U11) to produce a 4.772727 MHz system clock timing signal, CLK88. CLK88 is buffered through a 74LS244 tri-state octal buffer (U15) (not shown) to become the CLK signal applied to the expansion slots. The 8284 clock generator also produces a 2.386363

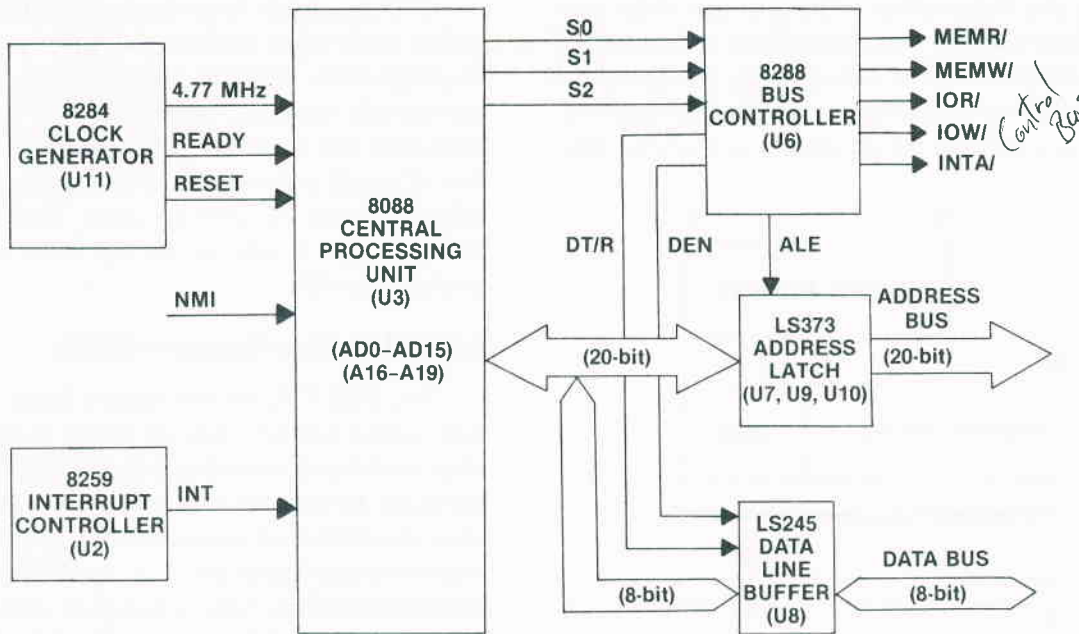


Fig. 2-8. The 8088 CPU and its support circuitry.

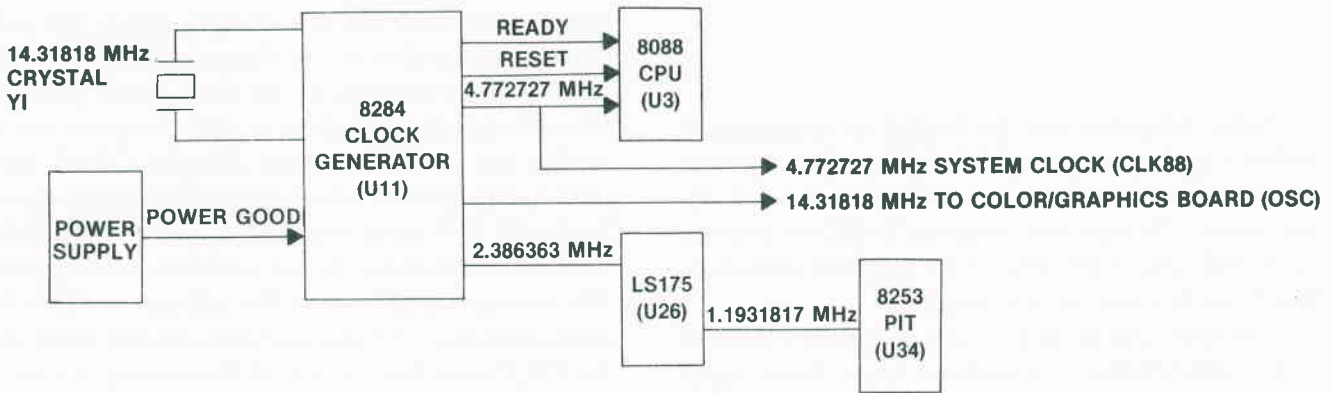


Fig. 2-9. The IBM PC clock circuitry.

MHz intermediate clock frequency, which is divided by 2 in the 74LS175 quad-D flip-flop (U26) to provide a 1.1931817 MHz clock signal to the 8253 programmable interrupt timer (U34).

The basic clock signal, OSC, is provided to the color graphics board where OSC is used to develop the synchronization and horizontal scan signals. The system clock signal is also available on the I/O connectors (expansion slots).

Should your machine behave erratically, a sick clock may be your problem. (Another could be the

8088 CPU itself.) We'll learn more about this in Chapter 4.

### The 8259 Programmable Interrupt Controller

The IBM PC is an interrupt-driven machine. This means that all the input and output functions are controlled by or control other devices by means of interrupt signals. Each time one of the peripherals needs to communicate with the CPU, it requests to interrupt the CPU by sending a signal to the 8259 interrupt controller (U2). This controller chip places an interrupt signal, INT, on the input to the 8088, causing the CPU to stop processing and look at a special address for a subrou-

time to handle, or service, the interrupt. The CPU also places a special code on the S0-S2 lines to the 8288 bus controller (U6), causing the generation of an interrupt-acknowledge signal, INTA/.

Interrupts can be initiated by hardware (the chips themselves) or by a program that you are running in the machine. The key to hardware-interrupt generation is the 8259 programmable interrupt controller (U2), as shown in Fig. 2-10.

The programmable interrupt controller at U2 has eight interrupt-request-line inputs (IRQ0-IRQ7). These inputs are acted upon by U2 in a specific priority order. IRQ0 has the highest priority. If two interrupt requests arrive at U2 at the same time, the interrupt request with the number closest to 0 will take priority and be acted upon first. For example, if IRQ5 and IRQ3 interrupt request lines both go high at the same time, IRQ3 will be serviced first. Then IRQ5 will receive attention.

When the interrupt request is sensed by U2, the device generates an interrupt signal, INT, which is sent to the 8088 CPU. If interrupts are being accepted (you can turn them off with a software command), the 8088 sends a code to the 8288 bus controller (U6) causing an interrupt acknowledge (INTA/) signal to be returned to U2. Upon sensing INTA/, U2 places an 8-bit interrupt vector on the data bus.

This causes U2 to send a SP/EN signal to the 74LS10 triple 3-input NAND gate (U84), disabling the system

data bus buffer 74LS245 tri-state octal transceiver (U8) so U2 can control the data bus for that moment.

The 8088 CPU stores its internal condition (the address it is going to access next, etc.) and looks at the data placed on the data bus by the interrupt controller (U2). It interprets this data as specifying a memory location that equals four times the value of the interrupt vector from U2.

The CPU accepts the data stored at this location as the starting address of a subroutine to service the interrupt. It jumps to the subroutine and executes the instructions there. When the interrupt has been serviced, the subroutine will return the CPU to the initial program it was running. The initial conditions will be restored, and the CPU will go on about its business once more.

### 8255 Programmable Peripheral Interface

The 8255 programmable peripheral interface (PPI) at U36 is a smart peripheral device with an addressable data bus interface controlled by handshaking lines (special communications signals). On the input/output side, U36 has three programmable 8-bit ports. Each port can be configured as either input or output. The third port, port C, can be divided so it provides both input and output. The chip is configured by a control word sent to it on the data bus. U36 is configured as shown in Fig. 2-11.

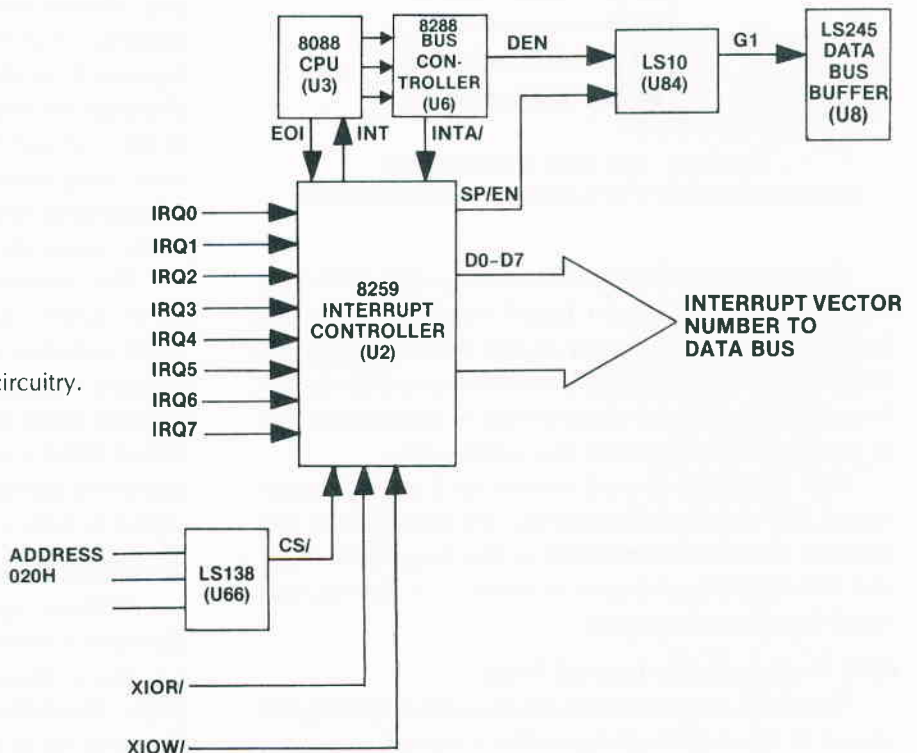
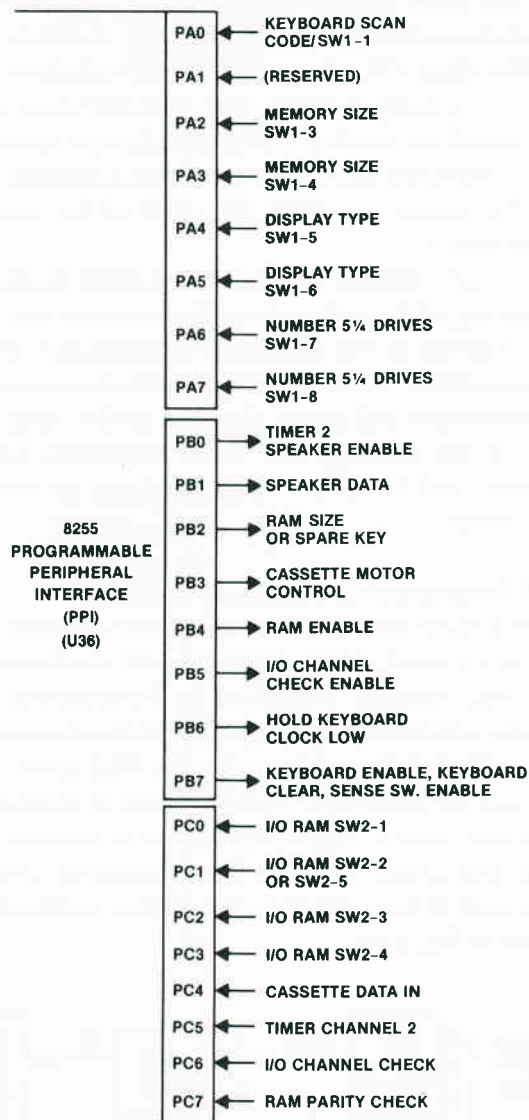


Fig. 2-10. The 8259 interrupt controller circuitry.



**Fig. 2-11.** The 8255 programmable peripheral interface (PPI) configuration in the IBM PC.

Depending on the status of bit 7 in port B (PB7), port A reads either the system board switch (SW1) or the keyboard. Port B is used to enable the 8253 programmable interval timer (U34), to turn on the speaker signal, to control the cassette motor (if one is connected), and to enable a RAM accuracy test called *parity*.

Port C is used to read switch SW2 on the system board, the status of RAM parity, the status of the I/O channel (the lines connected to the expansion slots), and the 8253 timer output channel 2. It also accepts input data from a cassette.

### 8253 Programmable Interval Timer

The 8253 *programmable interval timer* (PIT) (U34) shown in Fig. 2-12 is configured by a control word sent

to it over the data bus. The PIT at U34 receives a 1.1931817 MHz clock pulse from 74LS175 quad-D flip-flop (U26) and produces three important outputs. OUT0 is an 18.2 kHz interrupt signal (IRQ0) used to cause a time-of-day clock tick. OUT1 is a 15-microsecond clock pulse used to cause the dynamic RAM chips to be addressed (refreshed). OUT2 is a square-wave signal sent to the speaker. This output frequency can be varied under software control.

## MEMORY DESIGN

Your IBM PC comes with capability for 64K or 256K of onboard RAM. Since the 8088 CPU can address 1,048,576 locations, memory expansion capabilities have been designed to increase the onboard RAM to as much as 640K of available memory. The design requires that the onboard RAM sockets be fully populated (filled) before expansion boards are plugged into the slots. All the RAM, ROM, and additional memory cards are allocated within the 1-megabyte address space.

Address space is separated into areas for RAM, ROM, and input and output. Input and output ports have unique memory addresses—that is, the I/O is memory-mapped. For example, to send data to the speaker via 8255 PPI port B, line 1 (causing it to click), you address location 00061H (97 in decimal), and then you address the 8253 PIT at location 00043H (67 in decimal) to set the speaker output frequency. Addressing port C of the 8255 PPI at location 00062H (98 in decimal) will enable the system to read cassette data into bit 4 of port C. The map of memory allocation for your computer is shown in Table 2-1. For convenience, a decimal-to-hexadecimal conversion table is included in the Appendix.

The computer determines how much memory is in the PC system by the setting of two *dual in-line package* (DIP) *switches* mounted on the motherboard. When memory is added, the switch settings are changed to reflect the larger memory space available. The lower portion of RAM is used to store interrupt information and part of the operating system. This memory is allocated as shown in Table 2-2

### Read-Only Memory (ROM)

Memory spaces from C0000H to FFFFFH are allocated to ROM. These are allocated as shown in Table 2-3. These addresses can be translated to specific ROM chips. The ROM chip position U28 is an empty socket that was once planned for holding part of Cassette

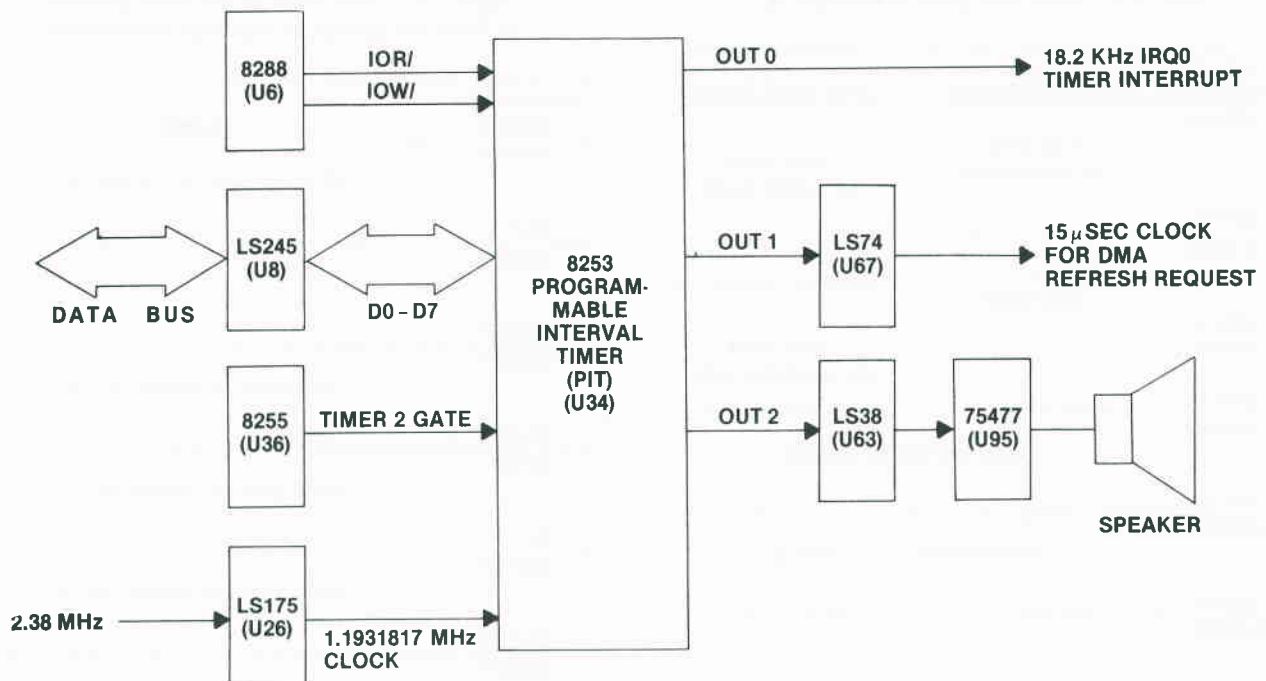


Fig. 2-12. The 8253 programmable interval timer (PIT) circuitry.

BASIC. Its allocated address space is F4000H to F5FFFH. The next four ROM chips, U29–U32, hold the 32K Cassette BASIC. Cassette BASIC resides in memory between F6000H and FDFFFH. ROM U33 holds the PC's basic input/output system (BIOS) routines. Its address allocation covers FE000H to FFFFFH.

The address space between C0000H and F3FFFH is reserved for future ROM application. If a hard disk is connected to the PC, addresses C8000H–CBFFFH are allocated for its control. All the memory below C0000H is allocated for RAM.

Stored permanently within the 8K ROM BIOS chip are software routines to handle video display graphics, printer and asynchronous communications, a time-of-day clock, printing the screen display, cassette operations, a minifloppy disk bootstrap loader, and a power-up self test.

The self-test (actually a series of tests) occupies 2K of the 8K ROM. This series of 14 tests is initiated when power is turned on. The tests check the 8088 CPU, the ROM, the RAM, the keyboard, the video display adapter card, the cassette recorder, and the floppy disk system. The RAM test includes five different read/write tests. The entire memory area available to the user is checked. Each of the five memory tests writes and then reads a different bit pattern into the memory locations.

Depending on how much RAM is in your system, the tests can take as long as 1.5 minutes. A 128K system takes about 30 seconds to conduct the tests and complete the system initialization process.

When the computer is restarted with the power already on, the system tests are bypassed, thus reducing the time to initialize by almost 40 percent.

The ROM circuitry is shown in Fig. 2-13.

Addresses A0–A7 are buffered through 74LS244 (U16) and combined with addresses A8–A12 buffered through 74LS244 (U15) to become XA0–XA12. These 13 address bits are applied to the address inputs to ROM chips U29 through U33. The addressed ROM is enabled by the chip-select signal decoded by the 74LS138 1/8 decoder/demultiplexer (U46). Its inputs include the seven highest address bits (A13–A19) and the extended memory read signal (XMEMR/). Address bits A16–A19 are used to develop the ROM address select signal (ROM ADDR SEL/). This same signal is combined with I/O read (IOR) and extended address bit 9 (XA9) in the 74LS02 quad 2-input NOR gate to determine the direction of data flow passing through the 74LS245 tri-state octal transceiver (U13) at the output of the ROM array.

Data read out of the ROM passes through U13 onto the data bus, where it can be accessed by the CPU.

**Table 2-1. RAM allocation in the IBM PC**

Hexadecimal Address	16K-64K System	64K-256K System
00000H	64K RAM on motherboard	256K RAM on system board
0BFFFH		
0C000H	576K RAM	384K RAM on expansion cards
3FFFFH		
40000H		
9FFFFH	128K reserved for displays	
A0000H		
AFFFFH	Monochrome video memory	
B0000H		
B3FFFH		
B4000H		
B7FFFH	Color/graphics video memory	
B8000H		
BBFFFH		
BC000H		
BFFFFH		ROM
C0000H		
FFFFFH		

## Random-Access Memory (RAM)

As pointed out earlier, there are two types of PC system boards. The first PCs to reach the public have system boards designed for 4116-type 16K-by-1-bit chips. Up to 64K bytes of RAM can be mounted on these boards. Newer PCs use the 4164-type 64K-by-1-bit chips. Up to 256K bytes of RAM can be mounted on the newer boards. Another 384K bytes of RAM can be added by using the expansion slots, providing a total of 640K bytes of available RAM space.

RAM can be described as a read/write type of memory. These chips can have programs written into them, and they can have programs or data read from them. The RAM is like the scratch pad or blackboard for the computer, whereas the ROM could be considered a book that the computer reads.

Unlike ROM, anything stored in RAM disappears when the computer's operating voltages are removed. Hence, the statement earlier about saving the informa-

**Table 2-2. Allocation of the lower portion of RAM for storage of interrupt information**

Hexadecimal Address	Content
00000H	BIOS interrupt vectors (00-1F)
0001FH	
00020H	
0007FH	DOS interrupt vectors (20-3F)
00080H	
0009FH	USER interrupt vectors (40-7F)
00100H	
001FFH	BASIC interrupt vectors (80-FF)
00200H	
003FFH	BIOS data area
00400H	
004FFH	BASIC and DOS data area
00500H	
005FFH	62.5K user RAM area
00600H	
0BFFFH	

tion on a disk or cassette before turning the machine off.

As you saw in Table 2-1, your system board can hold either up to 64K of 4116 RAM chips, or up to 256K of 4164 RAM chips. Each board has four rows of nine chips. The ninth chip in each row is used for parity. Parity will be explained in detail shortly.

### Bank Addressing Scheme

Since there are four banks of RAM on the system board, a bank addressing scheme is used to write or read information into each part of memory (see Fig. 2-14). Address bits A14 and A15 are combined with RAM address select (RAM ADDR SEL/) and chip address select (CAS/) in a 74LS138 1/8 decoder demultiplexer (U47) to form the four bank chip address select signals, CAS0/, CAS1/, CAS2/, and CAS3/. The same two address bits (A14 and A15) are also combined with data acknowledge signal DACK0/ and RAM ADDR SEL/ in 74LS138 (U65) and then ANDed with the REFRESH

**Table 2-3. ROM allocation in the IBM PC**

Hexadecimal Address	16K-64K System	64K-256K System
C0000H		
C7FFFH		192K ROM expansion and control
C8000H		
CBFFFH	Hard disk control	
CC000H		
EFFFFH	Reserved for future use	
F0000H		
F3FFFH		(Open ROM socket) (8K)
F4000H		
F5FFFH		ROM Cassette BASIC (32K)
F6000H		
FDFFFFH		ROM BIOS (8K)
FE000H		
FFFFFFH		

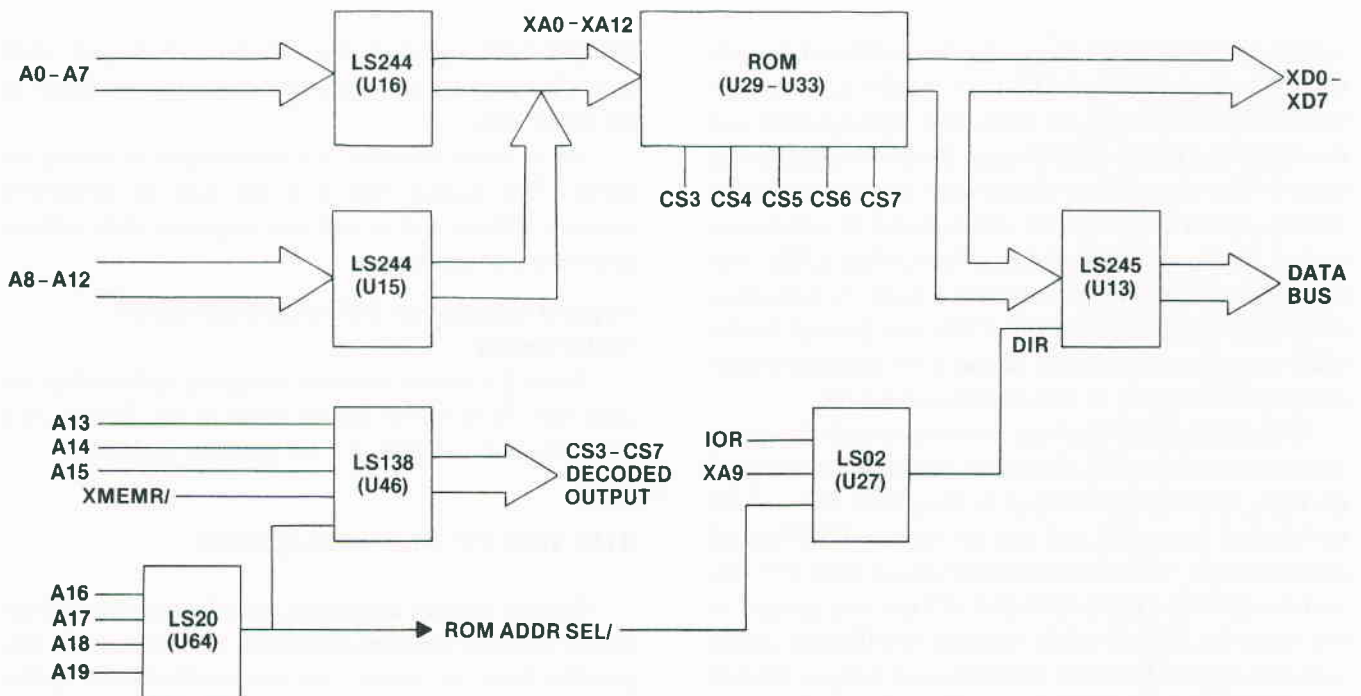
GATE/ signal in 74S08 AND gate U49 to generate four bank RAM address select signals RAS0/, RAS1/, RAS2/, and RAS3/.

As shown in Fig. 2-14, CAS0/ and RAS0/ enable the data passing through a 74LS245 tri-state octal transceiver at U12 (MD0-MD7) to be written to or read from Bank 0 RAM (U38-U45).

**Parity Checking**

The lone RAM chip at U37 is used for parity checking. Parity is a self-test to ensure that the data being read is accurate and that no bits have changed logic value (indicating a bad RAM chip). To understand how parity works, refer to Fig. 2-15. When the data is written (stored) into a memory location, all the logic 1's are added, and the parity bit is set or not set, depending on the outcome of the addition. The parity bit is used to ensure that the addition result is an even number.

The 8-bit data word (MD0-MD7) that is being stored in RAM (U38-U45) is passed to the 74S280 9-bit odd/even parity generator/checker at U94. This chip senses the number of logic 1's in the data word and places a logic 1 output from either an odd-parity output pin or an even-parity output pin. If the result is odd parity, the 74S280 places a logic 1 on its odd-parity output. This signal is passed through a 74LS125 quad tri-state buffer at U80 and into the parity RAM chip for that row of memory chips (U37 in this case). When the data



**Fig. 2-13.** The ROM circuitry.

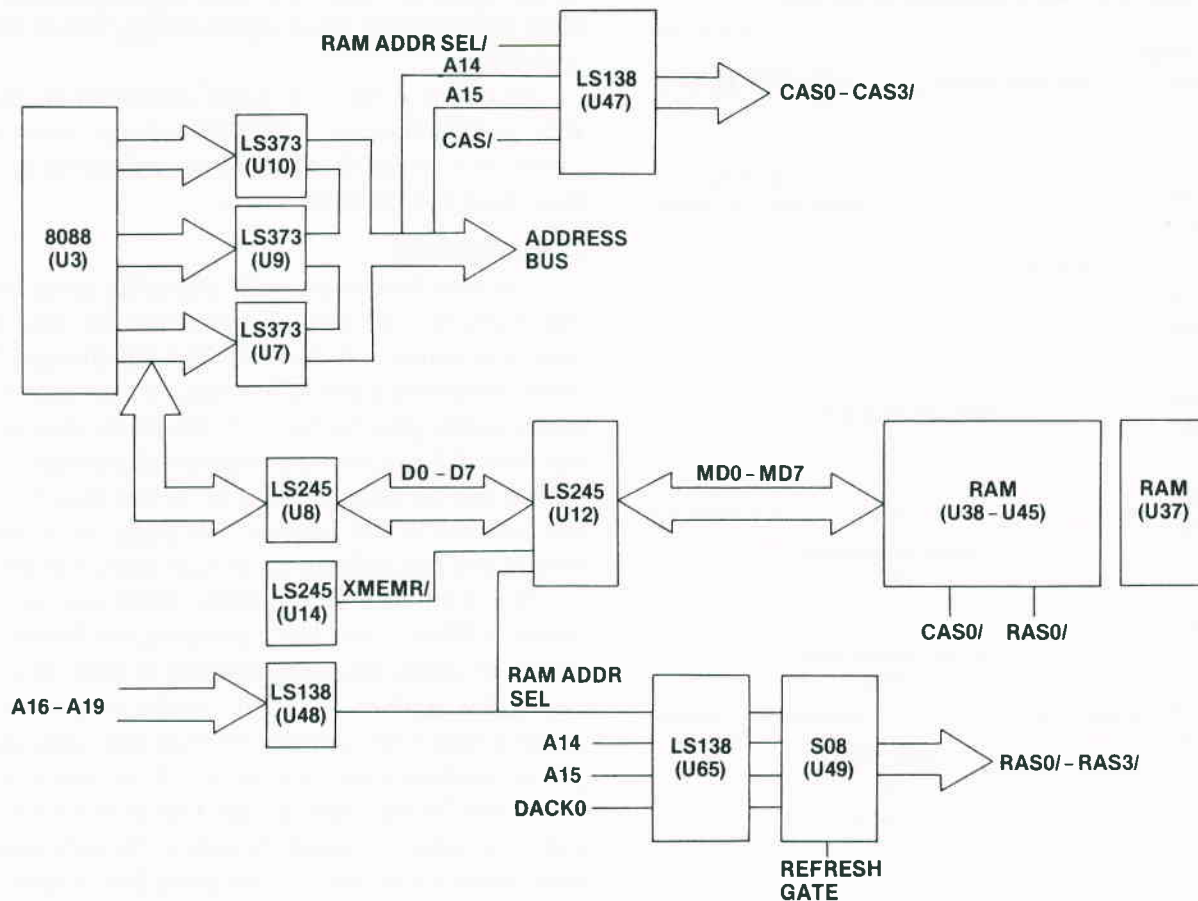


Fig. 2-14. RAM Bank 0 addressing scheme.

is read out of the RAM, the parity bit (MDP) is read with the data word (MD0-MD7) into 74S280 (U94). Since the result should now be even, the signal passed out the ODD line to the 74LS02 quad 2-input NOR gate is a logic 0. This signal is combined with the inverted RAM address select (RAM ADDR SEL/I) signal to produce a logic 1 set signal to 74LS74 dual-D flip-flop (U96). The Q output of U96 (PCK) becomes a logic 1, indicating that parity is good. The status of PCK can be read by the 8088 by addressing port C of the 8255 programmable peripheral interface at U36 (address 00062H).

If the data word read out of memory with the parity bit was sensed as odd, the ODD output of U94 would go high, causing U27 output to drop low. This would be latched into U96 and the Q/ output PCK/ would become high. When I/O channel check (I/O CH CK) and enable I/O check (ENABLE I/O CK) are sensed at the input to 74LS10 triple 3-input NAND gate (U84) with the signals from the 74LS00 quad 2-input NAND gate (U81) and the PCK/ from U96, U84 produces an output that is high. This logic high is ANDed with the

ALLOW NMI signal in the 74S08 quad 2-input AND gate U97, producing a nonmaskable interrupt (NMI) to the 8088 CPU.

All of RAM memory is continuously checked for parity. This built-in test is a fast way to determine memory failure and to prevent improper data utilization or transmission.

### Physical Location of RAM Addresses on the Motherboard

Table 2-4 relates memory locations to the chips on your IBM PC's motherboard. Refer to Fig. 2-5 for chip locations and to Table 2-1 for memory content.

## THE IBM PC BUS STRUCTURE

Control signals, addresses, and data are shared between the CPU and the rest of the PC system over tiny parallel lines, or traces, on the motherboard called *buses* (see Fig. 2-16).

A bus is like a roadway over which the 8088 CPU

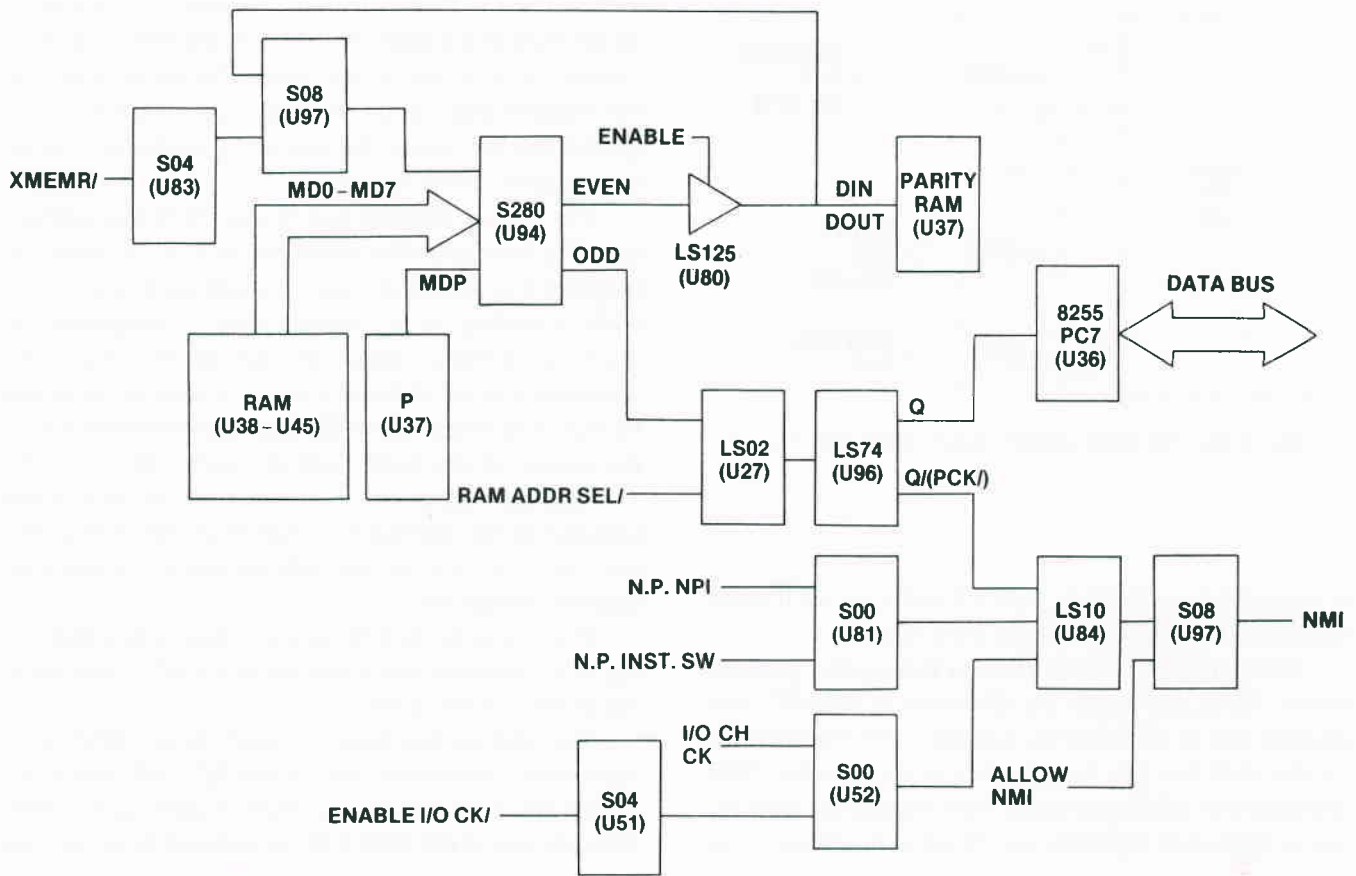


Fig. 2-15. The parity circuitry in the IBM PC.

Table 2-4. Memory location in relation to chip location

Function	Parity	D0	D1	D2	D3	D4	D5	D6	D7
<b>Memory Location (16K-64K)</b>									
Bank 0 (16K)									
00000H through 03FFFH	U37	U38	U39	U40	U41	U42	U43	U44	U45
Bank 1 (32K)									
04000H through 07FFFH	U53	U54	U55	U56	U57	U58	U59	U60	U61
Bank 2 (48K)									
08000H through 0BFFFH	U69	U70	U71	U72	U73	U74	U75	U76	U77
Bank 3 (64K)									
0C000H through 0FFFFH	U85	U86	U87	U88	U89	U90	U91	U92	U93
<b>Function</b>	<b>Parity</b>	<b>D0</b>	<b>D1</b>	<b>D2</b>	<b>D3</b>	<b>D4</b>	<b>D5</b>	<b>D6</b>	<b>D7</b>
<b>Memory Location (16K-256K)</b>									
Bank 0 (64K)									
00000H through 0FFFFH	U37	U38	U39	U40	U41	U42	U43	U44	U45
Bank 1 (128K)									
10000H through 1FFFFH	U53	U54	U55	U56	U57	U58	U59	U60	U61
Bank 2 (192K)									
20000H through 2FFFFH	U69	U70	U71	U72	U73	U74	U75	U76	U77
Bank 3 (256K)									
30000H through 3FFFFH	U85	U86	U87	U88	U89	U90	U91	U92	U93

communicates with other components (peripherals such as disk drives) and the outside world (motors, lights, sensors, etc.). Your IBM PC has an advanced bus design with all data and address output lines fully buf-

fered for protection. The IBM PC buses include:

- A data bus
- An address bus
- A control bus

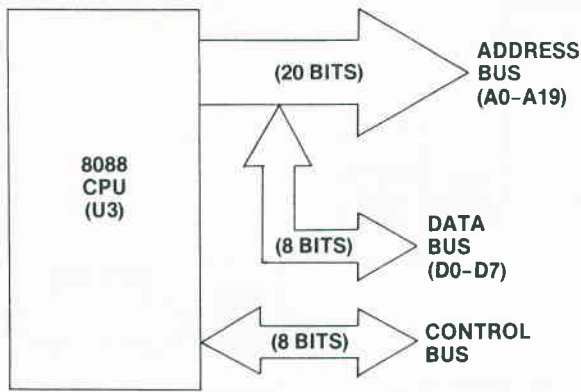


Fig. 2-16. The three primary buses in the IBM PC.

technically an “8-bit machine” because the data word on the data bus is eight bits wide. It requires a signal to control the direction of data flow. This signal is part of the **control bus**—a set of traces, or lines, on which special voltage signals are placed to enable or disable certain parts of the circuitry.

The largest (widest) bus in the PC is the address bus. This bus carries the addresses the CPU accesses for program instructions or data. The address bus is 20 bits wide, enabling it to address over 1 megabyte of memory locations. These 20 logic levels collectively represent unique address locations in memory or in the PC I/O. Addresses AD0–AD7 become unidirectional at the output of the buffer address latch 74LS373 (U7). The address output of U7 is called A0–A7 and is the low part of the address bus. Addresses A8–A19 come out from the CPU on the address bus on a one-way (unidirectional) path.

A voltage (approximately 0 or +5 volts) on each trace of each bus represents a logic level (0 or 1).

The **data bus** and the **address bus** are the primary buses. Data bus words are identified as D0–D7. The address bus is identified by bits A0–A19. Information on the data bus can travel either to or from the CPU (the data bus is bidirectional). Even though the IBM PC has a CPU that operates on 16-bit instructions, it is

The complete IBM PC bus structure is described in Fig. 2-17. Notice that the address bus is fully buffered to the ROM and the RAM.

The address bus passes through three 74LS373 tri-state octal transparent latch chips (U7, U9, and U10) before being applied to any other circuitry as A0–A19. The data out of the 8088 CPU is buffered by a 74LS245

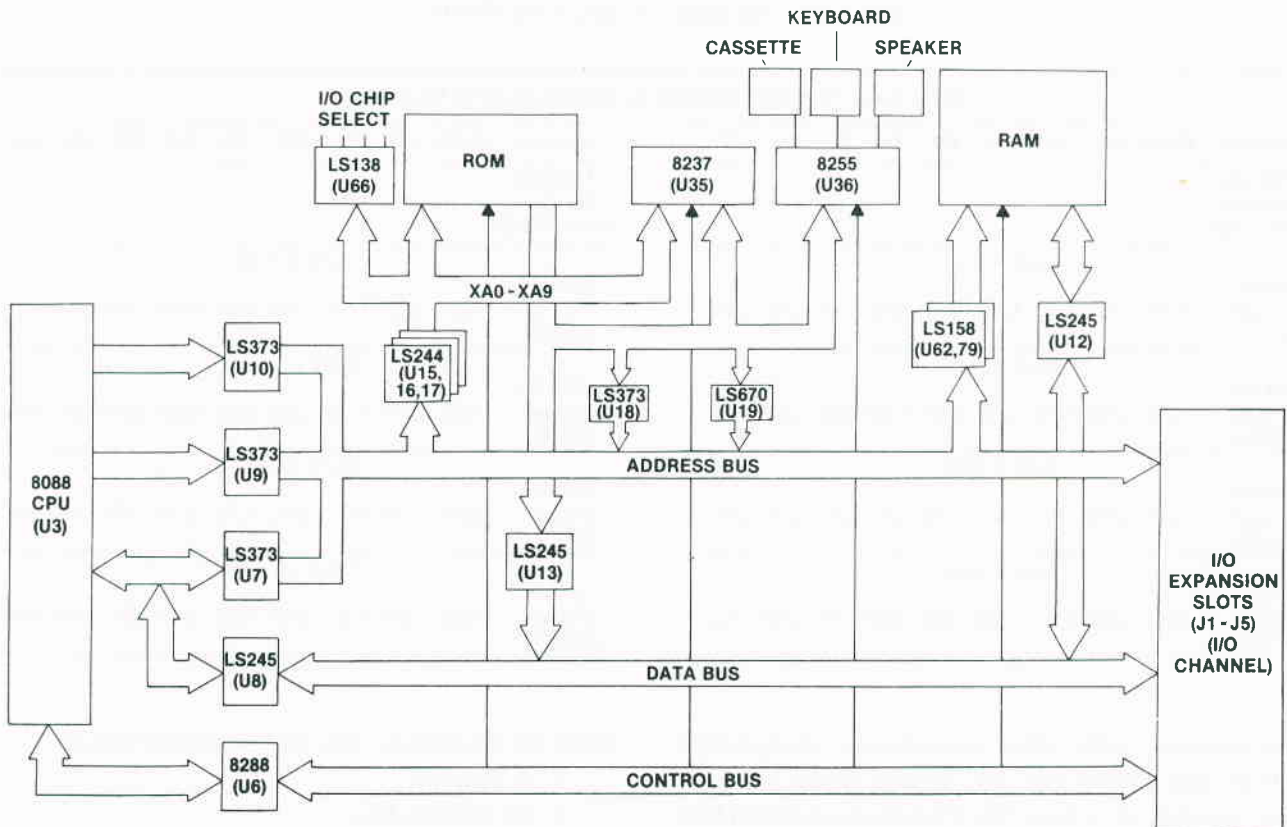


Fig. 2-17. The complete IBM PC bus structure.

tri-state octal transceiver (U8) before becoming the data bus D0–D7.

Several smaller bus structures are formed from the address and data buses. Part of the address bus is coupled through three 74LS244 tri-state octal buffer chips (U15, U16, and U17) to become the extended address bus XA0–XA9. Likewise, the data bus is passed through a second 74LS245 tri-state octal transceiver (U13) to become the extended data bus XD0–XD7. This extended bus connects directly to the ROM chips, the 8237 DMA controller, a 74LS373 tri-state octal transparent latch (U18) and a 74LS670 tri-state  $4 \times 4$  register file (U19).

Under the direction of the CPU, special control signals are placed on the control bus and unique addresses are placed on the address bus. The control signals open the address locations, letting the information stored in these locations appear on the data bus, which is acted on by the CPU or I/O.

Together, the address bus, the data bus, and the control bus are called the *system bus*. The system bus lies beneath those five expansion slots on your IBM PC motherboard.

In addition to the address bus, the data bus, and the control bus, the 62-pin system bus includes timing and power signals. It is accessible on five 62-pin I/O sockets mounted at the rear of the system board. Another name for this 62-pin arrangement is the *PC bus*.

Except for disk drive access signals, all data moves through the CPU and all addresses are generated and placed on the address bus by the CPU.

## INPUT AND OUTPUT

Each of the I/O ports, or windows through which information passes, has its own address. This is called memory-mapped I/O. Other CPU chips such as the 8080 and the Z80 use special instructions or commands to access the I/O ports. In the PC, you simply address a certain memory location in your computer to access the computer's ports.

Many peripherals have been developed for the IBM PC; and you have quite a bit of choice in connecting devices to your IBM PC to increase its capabilities.

### Video Display

IBM chose to produce all of its video signals external to the system board. Monochrome and color video displays are produced using one of two IBM display

adapters that plug into the expansion slots on the system board.

Only one video adapter board is required, although you can use two adapters should you wish to drive both color and black-and-white displays.

**Caution:** Do not connect the monochrome display to the color adapter. You could burn out the display unit.

An excellent description of video operation can be found in *The IBM Personal Computer from the Inside Out*, by Murray Sargent and Richard Shoemaker.

Both video adapters use a Motorola 6845 CRT controller. Because monochrome and color video are produced in different ways, each adapter will be discussed separately.

### Monochrome Video Adapter

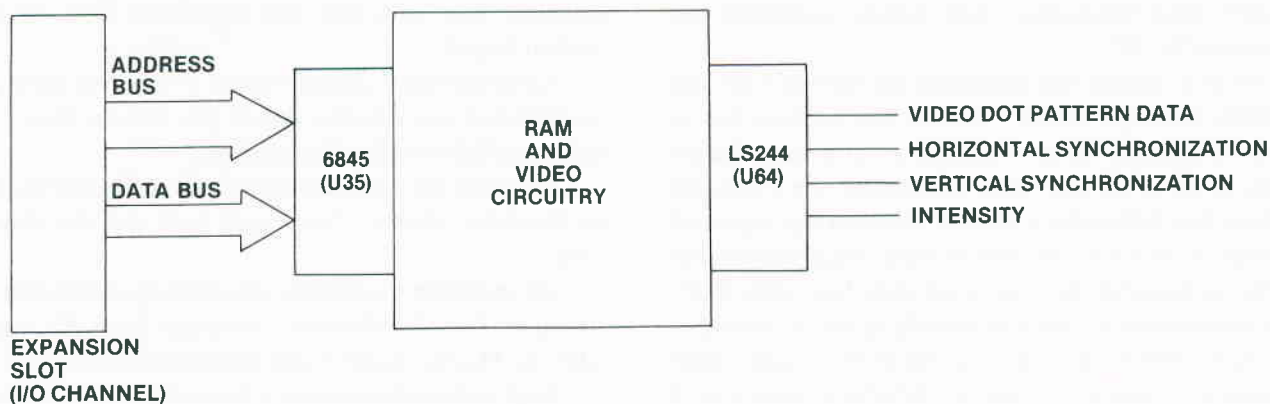
The monochrome adapter card has two functions. The first is to enable the system to display text via a 9-pin D-connector to a black-and-white display. A second connector is a 25-pin parallel-printer interface for the IBM 80-character-per-second printer. The connectors and signals are shown in Fig. 2-18.

PIN	SIGNAL
1	GROUND
2	GROUND
3	—
4	—
5	—
6	INTENSITY
7	VIDEO
8	HORIZONTAL SYNC
9	VERTICAL SYNC

**Fig. 2-18.** The signals present on the pins of the connector of the monochrome adapter card.

Each character is produced as a 7-dot-wide by 9-dot-high matrix within a larger, 9-dot-wide by 14-dot-high array. The extra dots on the top and bottom of the matrix are used for descenders (such as the letters "g" and "j," which have parts that extend below an invisible baseline) and for spacing between lines. Extra dots also provide spacing between characters on a single line.

IBM designed a custom adapter for its monochrome display. The adapter card generates nonstandard horizontal and vertical frequencies, so that few non-IBM monitors can be used with this adapter. In addition, the video output from the adapter card is not a composite video with the horizontal and vertical synchronization



**Fig. 2-19.** The input and output signals for the monochrome video circuitry.

signals combined with the video dot pattern data. Instead, as shown in Fig. 2-19, the two synchronization signals and the video data are provided to the display unit separately. The video data is in two parts: the video data itself and a brightness attribute.

The key device on the input to the adapter card is the 6845 CRT controller. This chip accepts the address and data buses and the clock inputs from the system board and converts these inputs to signals suitable for the video RAM and video circuitry. The 6845 produces the horizontal and vertical synchronization pulses. In between generating the sync pulses, the 6845 reads out the contents of the RAM into a character generator that translates the RAM data into video dot information.

At the output of the monochrome video circuitry, a 74LS244 tri-state octal buffer (U64) provides three separate video component signals to a 9-pin connector (labelled J3 on the adapter card). The IBM monochrome monitor can be connected to the PC via J3.

The monochrome adapter accepts ASCII character code from the system board data bus. An MK-36000 character generator converts the ASCII code into the appropriate dot pattern for display on the screen. The MK-36000 is an 8K ROM. It contains three character fonts, although only the font in the first 4K of its memory is used on the monochrome card.

Two bytes of data are sent to the adapter card for each alphanumeric character. One contains the ASCII code for that character; the second contains attribute information such as blinking, high intensity, normal, or reverse video.

The data from the 8088 CPU on the system board is stored in a fast static 4K RAM on the adapter card as shown in Fig. 2-20. The starting address of this video

buffer is B0000H. This address corresponds to the upper left corner of the screen. With 2 bytes per character, the full 4K of memory is required to store 25 lines of 80-character display (25 lines  $\times$  80 characters per line  $\times$  2 bytes per character = 4,000 bytes). The lower right corner of the screen corresponds to the top of the 4K memory (address B0F9FH).

When the 6845 controller determines that display data is required, it causes the ASCII code and attribute data stored in RAM to be read out and temporarily latched in two octal flip-flops. The 8-bit character data word is then sent into the MK-36000 character generator ROM. The other input to the MK-36000 is a 4-bit address code defining which row of dots for the ASCII character will be passed out to the 74LS166 8-bit shift register (U32). U32 receives the video dot pattern as a parallel word. After one dot-pattern word has been loaded into U32, it begins to shift the word serially out (one character at a time).

The attribute data is combined with the dot stream to produce a modified dot pattern that reflects the attribute data received. This signal is then clocked to the output of the video circuitry, where it enters the video cable attached to the 9-pin connector on the adapter card. The signal passes out of the adapter card, through the video cable, and into the display monitor, where it is converted into high-voltage electron beams that illuminate the P39 phosphor on a certain row of the screen.

The two signals that control where on the screen the dot character shape appears are the horizontal and vertical synchronization signals (syncs). These two signals are produced by the circuitry shown in Fig. 2-21.

Both sync signals originate in the 6845 CRT controller (U35). The 15.75 MHz horizontal synchroniza-

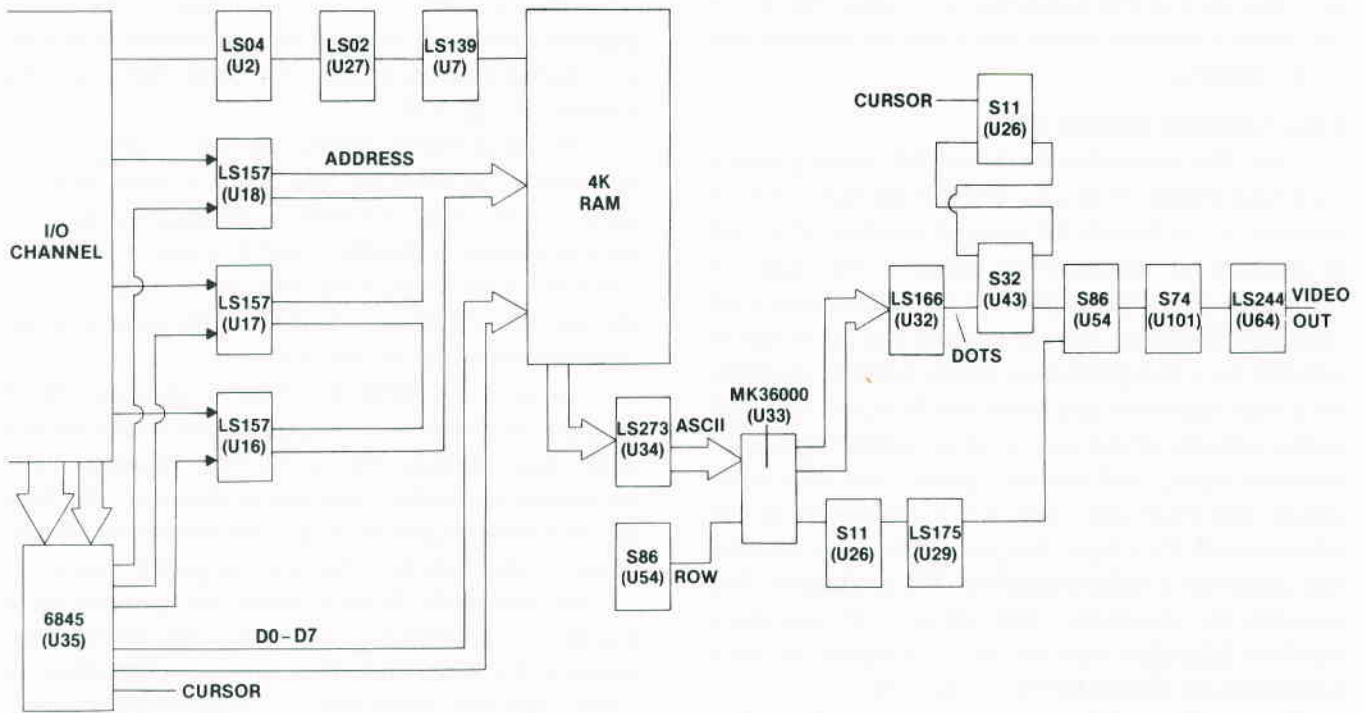


Fig. 2-20. The circuitry that produces the monochrome video signal.

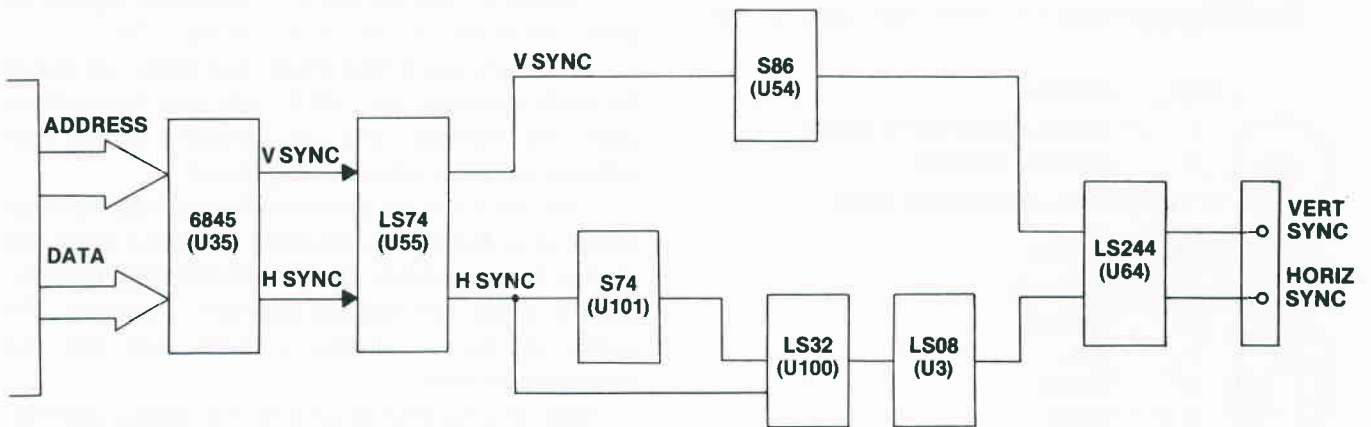


Fig. 2-21. The horizontal and vertical synchronization signals are produced in this circuitry.

tion signal is used to move the beam of electrons that leaves the CRT (cathode ray tube) cathode according to the video data dot pattern. When a dot is received, the cathode sends a stream of electrons out toward the place on the screen where the horizontal synchronization circuitry is aiming the electron beam. The electrons strike the P39 phosphor on the inside surface of the screen, causing that point or picture element (pixel)

to be illuminated, or to shine. Then the dot signal passes, the horizontal sync signal moves the beam to the next pixel, and if another dot is received, another pixel is illuminated.

At the end of the horizontal sweep, the electron beam is held low (blanked) and the horizontal aiming is retracted. Simultaneously, the 50 Hz vertical sync signal is applied, moving the stream of electrons down to the

next row so that the horizontal sync signal can move the beam across the screen and trace out another row of dot patterns.

### Color/Graphics Adapter Card

Like the monochrome card, the color/graphics card has circuitry on it to handle alphanumeric text. In addition, it can handle bit-mapped graphics. The card produces three distinct video outputs. One output is composite video. It is available at an RCA connector on the rear of the card. Another output is a set of signals suitable for a red-green-blue (RGB) monitor, available on a 9-pin connector just below the RCA jack. The RGB output consists of the two synchronization signals, an intensity signal, and the red, green, and blue color signals. The third video output is in the chassis on the adapter card. It's a 4-pin Berg strip providing a connection point for a radio-frequency (RF) modulator. This provides the composite video signal to let you use a standard television with the PC. The signals on each connector are shown below in Fig. 2-22.

There is also a light pen connection on the color/graphics adapter card, but this input device is not often used with the PC. A mouse is the current popular input device (besides the keyboard).

The same type 6845 CRT controller used on the

monochrome adapter card is also used on the color/graphics card, but it must be reprogrammed each time you change graphics modes. The color video circuitry is shown in Fig. 2-23.

The monochrome adapter also has a built-in dynamic RAM. The RAM on this board is used to store alphanumeric data and bit-mapped graphics data. Its starting address is B8000H, and it is 16K bytes wide. The RAM is slower than the static RAM on the monochrome adapter, so some blinking of the screen can be observed when the display scrolls.

The same MK-36000 8K character generator ROM used on the monochrome adapter card is used on this card. Now, however, two of the three character fonts are jumper selectable. One font produces a 7-dot-high by 7-dot-wide double-dot character; the other font produces a 7-dot-high by 5-dot-wide single-dot shape.

The MK-36000 ROM contains dot patterns for a number of applications, including the 96-character standard ASCII set, 48 foreign language characters, 16 Greek alphabet characters, 15 engineering/scientific characters, 15 word processing characters, 16 game shape characters, and 48 block-line-circle shapes for use in business graphics.

Horizontal and vertical synchronization signals are produced in the circuitry shown in Fig. 2-24.

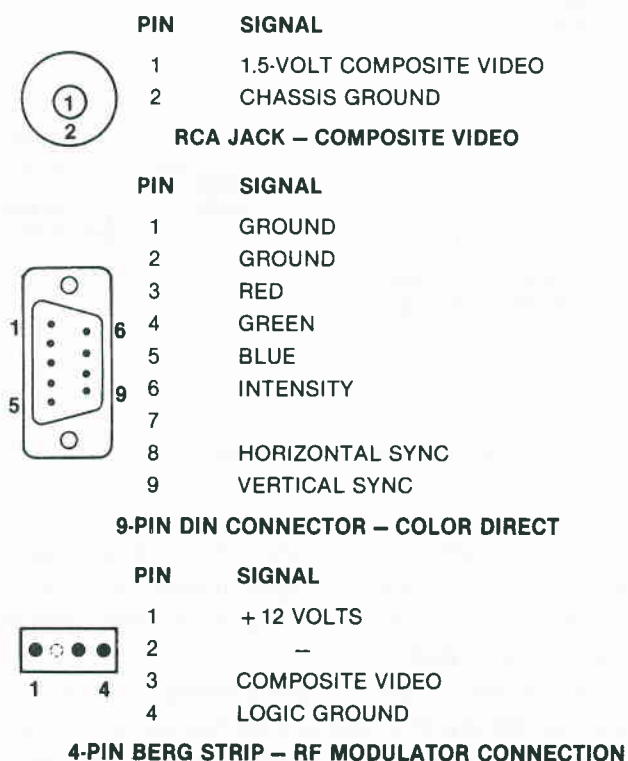
In alphanumeric text mode, two bytes are stored for each character: the ASCII code and the attribute code. The attribute code can provide a display with colored text on a colored background.

The characters are produced from a 7-dot-by-7-dot matrix in an 8-dot-by-8-dot array. There is a single line of dots for descenders, so no underlining is possible. With a single dot spacing between characters, the quality of the text display is lower than with the monochrome card.

Both 80-character-by-25-line and 40-character-by-25-line text modes are supported. The latter mode enables a color television set to be used as a display device. In both text modes, you can have up to 16 foreground colors and 8 background colors.

Three bit-mapped graphics modes are available: a low-resolution graphics mode with 160 dots, or pixels, horizontally and 100 pixels vertically; a medium-resolution mode with 320 pixels horizontally and 200 pixels vertically, and a high-resolution mode with 640 pixels horizontally and 200 pixels vertically.

In low-resolution graphics 16 colors are available; in medium-resolution graphics you can get 4 colors; and in high-resolution graphics, you are limited to black and white only.



**Fig. 2-22.** The signals present on the pins of the three connectors of the color/graphics adapter card.

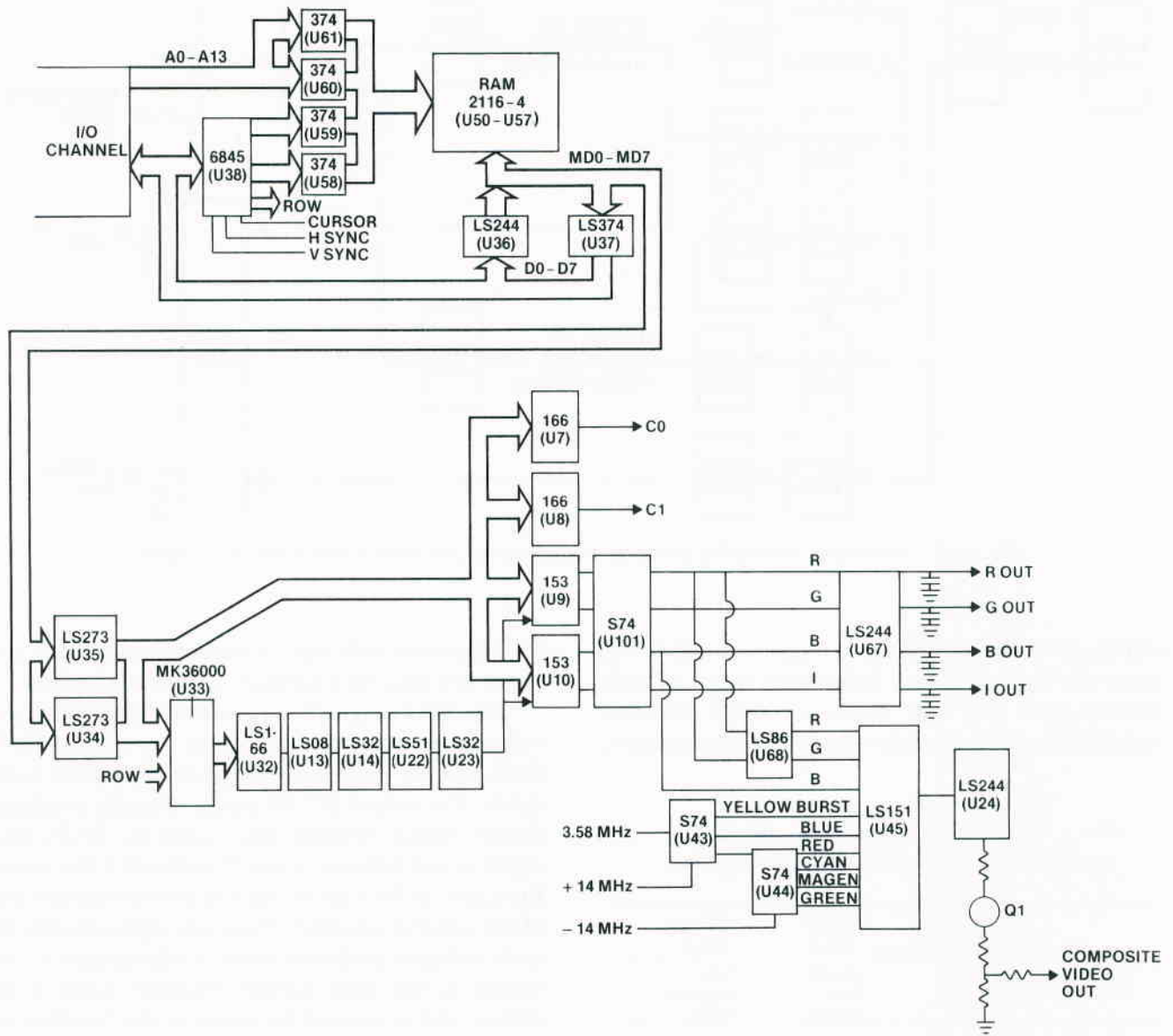


Fig. 2-23. The color video circuitry.

In medium-resolution graphics mode, each pixel on the screen is specified by two bits, so four pixels can be described in one byte. Two color sets are available as shown in Table 2-5. To select the color set, the program sends a byte to I/O address 3D9H. This is the address of the color-select register. Bit 5 selects the active color set. When bit 5 is logic 0, color set 1 is selected. A HIGH in bit 5 selects color set 2. With the color set selected, the two bits specifying the pixel can be described as shown in Table 2-6.

In high-resolution graphics (available in black and white only), each pixel is described by a single bit. A bit

value of 1 means that pixel is turned on (becomes bright). This allows each of 640 pixels across by 200 rows down to be bright or dark. The status of the 128,000 pixels on the screen can be stored in 16,000 bytes of memory (128,000 bits / 8 bits per byte = 16,000 bytes).

In text (alphanumeric) mode, the color/graphics adapter card operates much like the monochrome card. The big difference is that the color/graphics card has 16K of on-board RAM. This provides the capability to store four pages of text at one time. Any one page can be displayed at a given time. Changing the starting

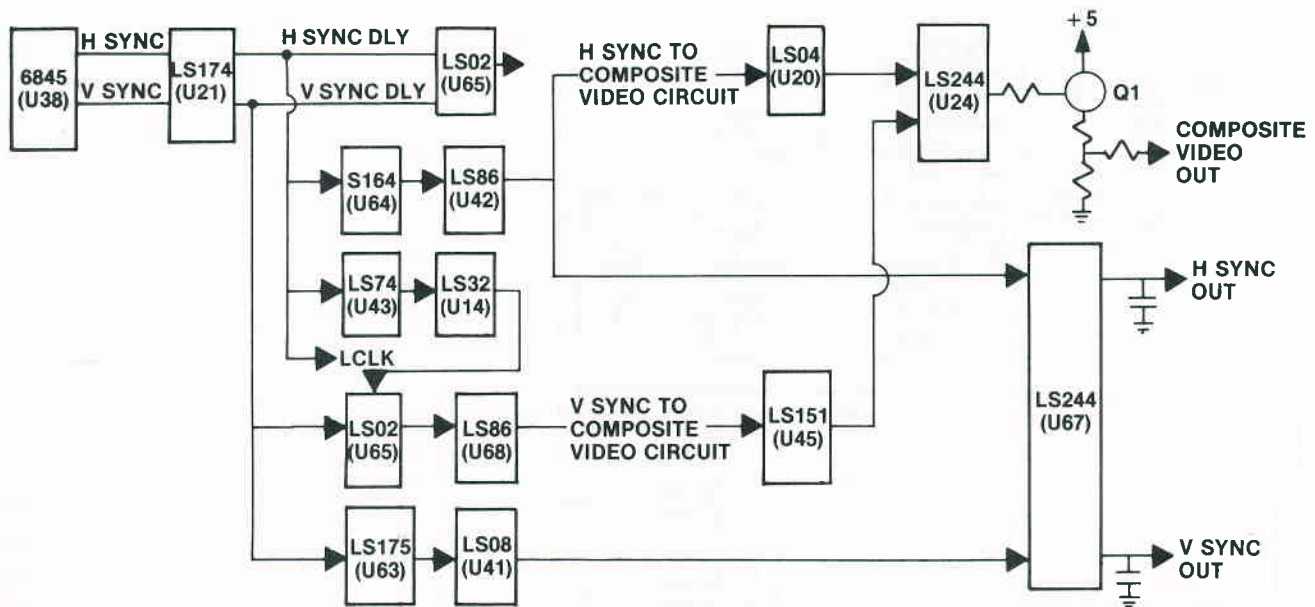


Fig. 2-24. The color circuitry that produces the horizontal and vertical synchronization signals.

address in 6845 CRT controller registers C and D will cause the card to access a particular page. As with monochrome text, two bytes—an ASCII character code and an attribute code—describe each character.

Table 2-5. The two color sets available in medium-resolution graphics mode

Color Number	Color Set 1	Color Set 2
1	Green	Cyan
2	Red	Magenta
3	Brown	White

Table 2-6. Bit settings for pixel specification

Pixel Bits	Function
C1 C0	
0 0	Dot becomes background color
0 1	Dot becomes color number 1
1 0	Dot becomes color number 2
1 1	Dot becomes color number 3

### Cassette Input and Output

The cassette interface is probably the least used of any PC accessory. Control of this interface is only available through software written in Cassette BASIC.

The simple circuit in Fig. 2-25 enables you to store programs and data on a standard audio cassette tape.

The 8253 programmable interval timer (U34) provides the cassette data stream to the cassette DATA OUT circuitry via a 74LS38 quad 2-input NAND buffer (U63). The output of U63 passes through a voltage-divider resistor network that causes the DATA OUT signal to shift between 0 and 75 millivolts if the jumper (Berg pin) on P4 is set for input to the microphone jack of the cassette recorder. These are approximately the same voltages produced when a microphone is connected to the same cassette recorder input. If the jumper is set to connect the output to the "auxiliary in" jack on the recorder, the audio signal is output at a higher voltage (0–0.68 volts).

**Caution:** Be careful when using a cassette recorder. The jumper pin setting is critical. If you connect the Berg pin so that the output is as much as 0.68 volts and then connect the cable to the microphone input to the recorder, you could damage the recorder electronics.

A 5-pin circular cable can be connected from the cassette port (J6) to the microphone or auxiliary input to the recorder. This special cable is not supplied or sold by IBM. The cassette recorder motor can be turned on or off by addressing bit 3 of port B (PB3) of the 8255 programmable peripheral interface (U36). Address 061H accesses this port. The MOTOR OFF signal is buffered through the 74LS138 quad 2-input NAND buffer (U63)

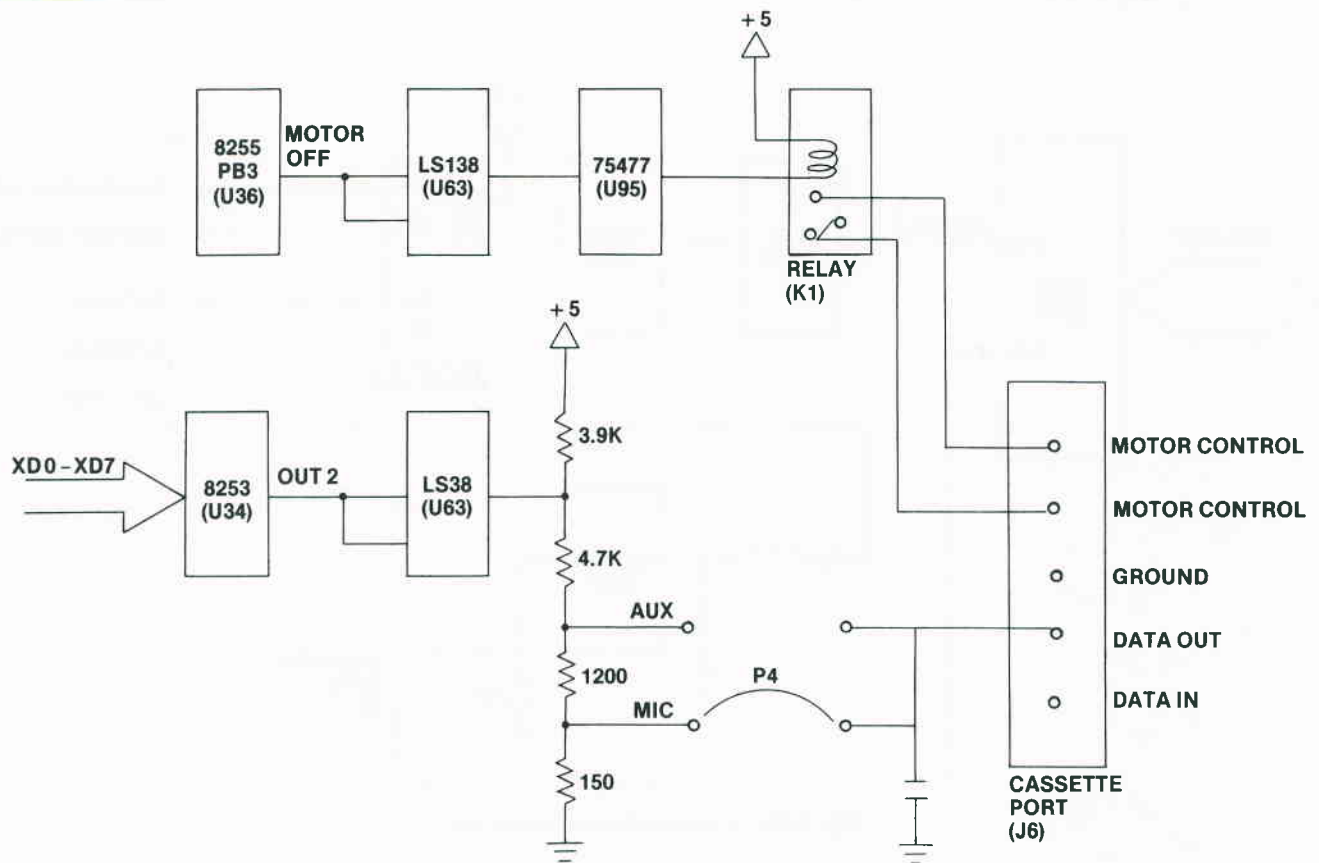


Fig. 2-25. Cassette data output circuitry.

into the 75477 relay driver (U95). When the output of U95 goes low, a relay (K1) energizes to close the motor-control lines from the recorder.

Cassette data is read into the PC via the DATA IN pin of J6 as shown in Fig. 2-26.

The 8255 programmable peripheral interface (U36) is the key device. It produces the MOTOR control signal out port B (PB3) as with data writing. The 500-nanoamp,  $\pm 13$ -volt DATA IN signal connects to the MC1741 operational amplifier (U1) when relay K1 is energized. Amplifier U1 modifies the data signal level to the voltages (0 and +5 volts) required for the digital logic circuitry. The data stream passes over the cassette DATA IN line into the PC4 input to port C of U36. From there it can be read on the data bus by your program. Programs are used to generate and read cassette data. Data can be read into the PC at speeds between 1,000 and 2,000 baud (approximately 100 to 200 characters per second).

## The Disk Drive

The floppy disk drive used in the PC allows you to easily and quickly store and retrieve information using 5¼-inch floppy disks. Several manufacturers, including CDC's MPI, Tandon, and Teac, provide disk drives that

operate within the PC system. IBM provides CDC and Tandon drives for their configuration of the PC. This guide will discuss primarily the IBM-supplied disk drive. The disk mechanism is housed in a 3.38-inch by 5.87-inch by 8.00-inch metal case. Each drive adds 4½ pounds of weight to the system.

### The Disk Controller Card

Data and control signals are supplied to each drive via a ribbon cable connected to a disk controller card plugged into one of the PC system board expansion slots. Up to two internal and two external disk drives can be supported from one disk drive adapter card. The disk drive is one of the most important peripherals connected to your computer. It's the primary mass storage device used by PC owners all over the world.

The 40-track cam-positioned drive rotates at 300 rpm to write or read data on a thin mylar disk with a magnetic coating of oxide particles. During manufacture, a .003-inch-thick polyester disk is coated on both sides with a .0001-inch layer of iron oxide. The disk is called a "floppy" because it is thin and quite flexible.

The type drive determines what kind of disk (or diskette) is used in the PC. A disk can be a single- or double-sided, double-density platter whose surface is

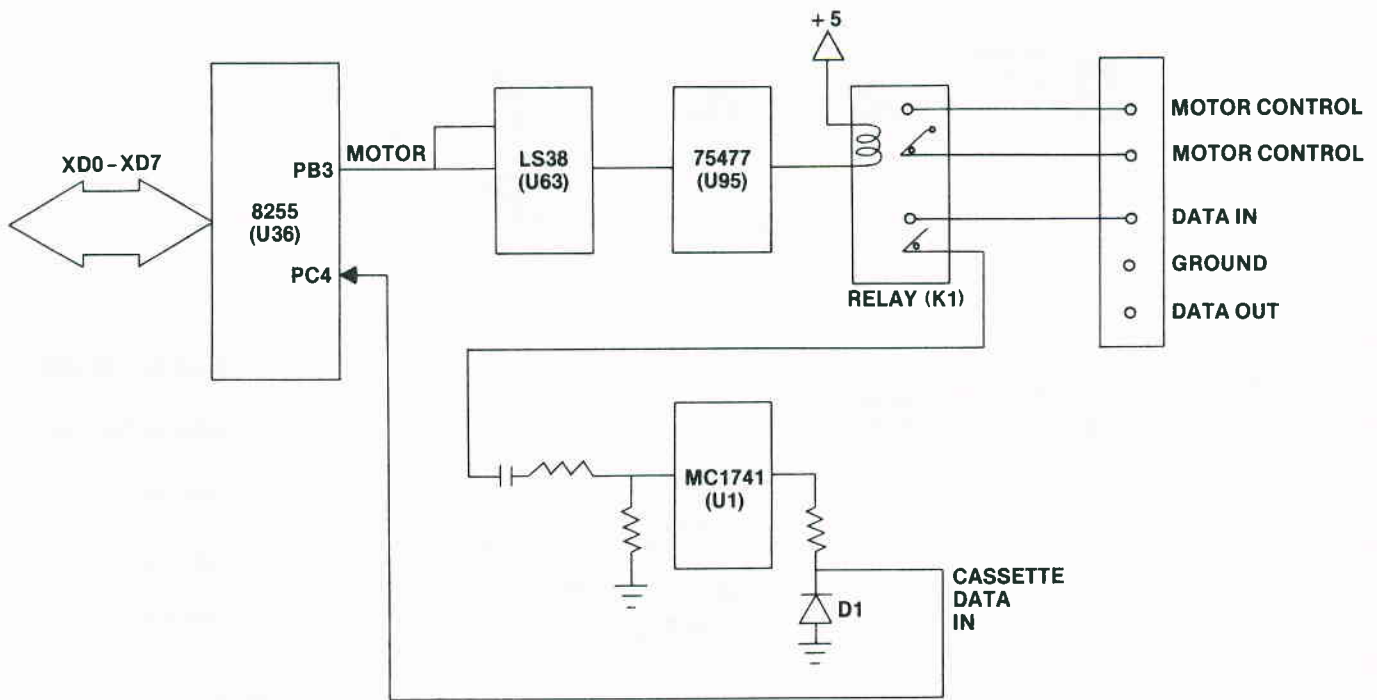


Fig. 2-26. Cassette data input circuitry.

electromagnetically divided into 40 tracks or rings leading from the center hole to the outer edge.

Each disk is soft sectored; that is, sectors are marked off by a special series of code bits written on the disk by the PC. The disk is divided into eight 512-byte sectors (nine for PC-DOS 2.x systems), providing 163,840 bytes of storage space per single-sided, double-density disk (184,320 bytes with PC-DOS 2.x), and 327,680 bytes of storage per double-sided, double-density disk (368,640 bytes with PC-DOS 2.x). One double-spaced page on 8½-by-11-inch paper can use up 1670 characters or bytes. Therefore, you can store a little over 98 pages of double-spaced text on one single-sided disk.

**Data Transfer**

The key to data transfer between the PC and the disk drive is a tiny chip on the system board called a DMA controller. The 8237 *direct memory access (DMA) controller* (U35) shown in Fig. 2-27 enables the computer to move large blocks of information (up to 64K) from disk to computer, computer to disk, or disk to disk.

The DMA controller has a 6:1 speed advantage over the CPU. It gains control of the data bus when a DMA request (DREQx) signal is received. When an external device (such as a disk drive) is ready to send data, it activates one of the four DREQ lines. The DMA controller acknowledges the request by activating the

appropriate DACK line. The chip also supplies a memory address and sends a signal to all the other I/O devices, disabling them from using the data bus.

Fig. 2-28 shows how the 8237 DMA controller (U35) is used in the I/O circuitry. The 8237 DMA controller has four channels dedicated for fast data transfer. A channel can be considered the combination of a DREQ line, a DACK line, and the data bus. Channel 0 is used for memory refresh. The 8253 interval timer sends a pulse out its OUT1 line every 15 micro-

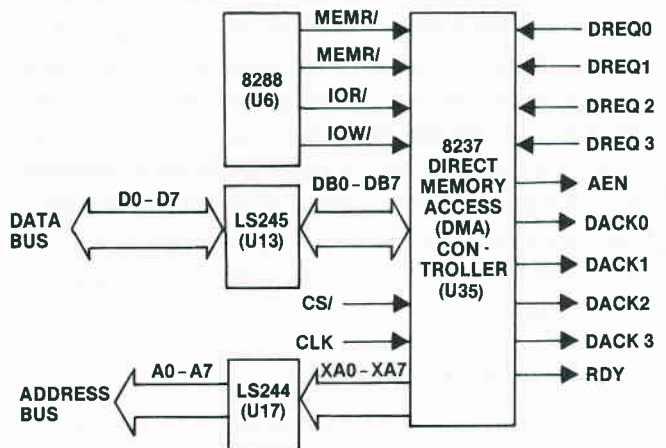
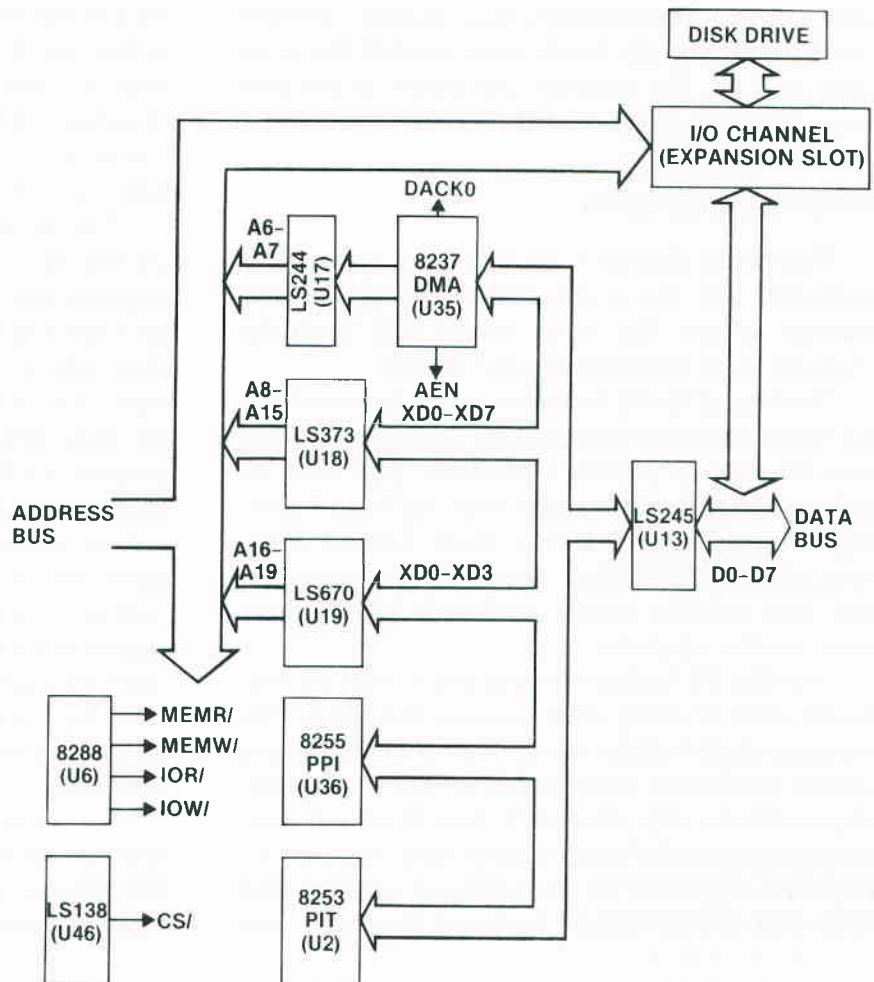


Fig. 2-27. The 8237 direct memory access (DMA) controller circuitry.

**Fig. 2-28.** The 8237 DMA controller interface to the I/O circuitry.



seconds. This pulse causes a flip-flop to generate a DREQ0 signal. The DACK0 response from U35 clears the flip-flop. The address placed on the address bus by the DMA chip causes some part of RAM to be accessed. The data isn't used because all the other I/O devices are disabled, but the memory was accessed, so the charges in the RAM cells are refreshed. As noted above, this occurs every 15 microseconds.

The PC is designed so DMA channel 2 is used for floppy disk data transfers. These movements of information occur at a 32-microsecond per byte rate. After the first byte transfer occurs (in five clock periods), each following byte of data is transferred in three clock periods.

Before data is transferred, the starting address and the number of bytes to be transferred are sent to U35. Then, once the data exchange has been activated, the disk drive will continue to write data to RAM until all the bytes have been sent. Once disk drive action is complete, data bus control is returned to the bus controller on the system board, and the system board lets

another device use the data and address buses. The DRIVE RUN light goes out, and the program you are running continues.

**Note:** Some PC users purchase disk drives separately and then install these drives in their computer system. It's important to recognize that some drives must be modified in order to be used in the PC. For example, the Tandon TM100-1 drive purchased separately has six links on a jumper dual in-line package (DIP) socket that must be broken in order for this drive to function properly in the computer. If you install disk drives yourself, be aware that they may need to be modified.

### Multifunction Boards

Some interesting multifunction boards have been introduced that dramatically improve the mass storage capability of the PC. One such board (JRAM from Tall Tree Systems) provides 512K of additional RAM and software that enables you to use a quad drive (four times the density) to achieve 800K of storage on one

disk. Several manufacturers now market controller cards that let you use 8-inch drives or hard disk drives with your PC. The selection and variety of enhancement interfaces grows monthly.

### Keyboard Operation

When you depress a character key on your PC keyboard, you see a character displayed on your monitor screen. But what causes that particular character to be displayed on your screen?

The keys of the PC keyboard have a feel much like the highly successful IBM Selectric typewriter. Besides keys standard to electric typewriters, your IBM PC keyboard includes some special keys: the Enter, Home, Page Down, Page Up, Delete, Insert, Control, Alternate, and Print Screen keys, as well as 10 function keys. IBM also provides special keyboards for computer users in other countries.

The IBM PC keyboard works better than the keyboards used on many other personal computers. The keyboard itself includes a matrix array of momentary contact pushbutton switches and an 8-bit 8048 single-chip computer with internal 2K byte ROM and associated electronics to handle control tasks. Fig. 2-29 is a simplified schematic of the keyboard circuitry. The 8048 chip of this "smart" keyboard (keyboard with

built-in electronics) can scan the matrix for key-press action four to six times faster than you can press the keys to close a keyswitch. Even the simultaneous depression of two or more keys (known as cord keying) can be handled easily with an on-board processor that can scan and react this quickly.

The 83 keys on the board are connected to a 23-row by 4-column switch matrix. Each time you depress a key, you close a switch at a crossover point of an X row and a Y column on the matrix. The signal thus generated is read by the 8048 processor and converted into a special code called a "scan code" that is sent to the 8088 CPU for interpretation. Every 3 to 5 milliseconds, the 8048 scans the keyboard matrix, checking columns one at a time to see if any line is low. First, one column is scanned, and the states of the switches in each row in that column are read and stored in memory. If a switch was closed, that crosspoint (intersection of a row and column) will be at 0 voltage. The scanning continues until all four columns have been read. Each scan code is stored in a buffer within the 8048. Thus the buffer reflects the status of the entire keyboard.

But the scan doesn't stop here. Next, the array is searched for the existence of a phantom switch condition (several switches in a rectangular pattern in the matrix depressed together and falsely encoded). If two

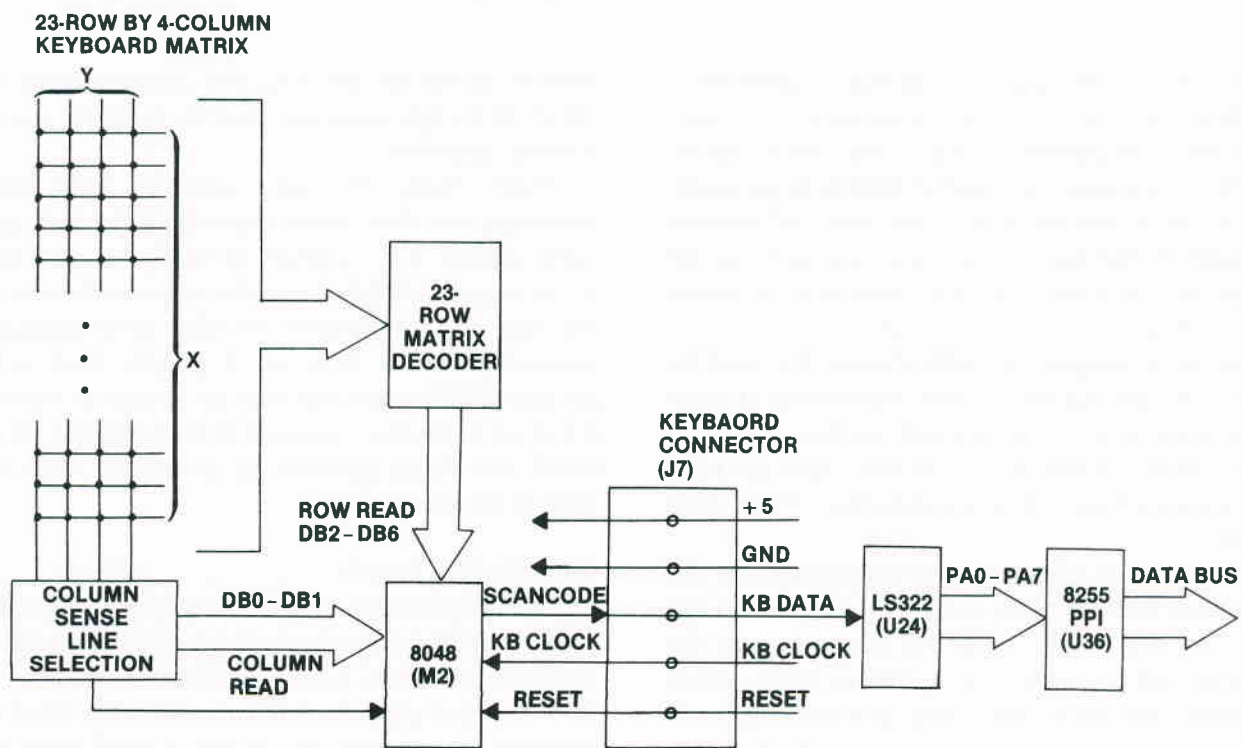


Fig. 2-29. The keyboard circuitry.

closed switches are found in the same column and one of the two rows containing the closed switch has another switch closed, a phantom switch condition has occurred. These conditions are evaluated by the 8048 and generally ignored. Only legitimate key closures (including the dual and triple key operations when one or more keys are held down while another key is pressed) are accepted. Because the scan process is performed in 3 to 5 milliseconds and there is an interval of at least 20 to 50 milliseconds between key entries, the matrix is scanned at least once every keystroke and incorrect entry is eliminated.

During the scan process, when a switch contact closure is sensed, the 8048 waits a few milliseconds to let the key closure settle out. One of the problems with mechanical switches such as keys is that they don't close cleanly. Electronically, they "bounce" several times before solid contact is achieved. This bouncing can produce noise spikes that could be interpreted as valid signals, causing such effects as four or five repetitions of a character from one key action. To counter this, the 8048 provides a short (several millisecond) delay before the key action is encoded and an interrupt is generated.

Each key action generates a unique scan code as shown in Table 2-7. Special functions and uppercase characters can be generated by depressing the Shift/Ctrl/Alt keys and one or more characters. The 8088 BIOS checks for the presence of a special key (Shift/Ctrl/Alt) signal when other keys are pressed. This signal and the character key scan code result in the special function or uppercase character generation.

The 8048 generates a scan code when a key is depressed and when the key is released. Depressing the "p" key causes the 8048 to generate the hex code 19H (00011001 in binary). When you remove your finger from the key, the 8048 generates the code 99H (10011001 in binary). Notice that only the high bit of the binary number has changed. This is the same as adding 128 (decimal) to the number. Once this code has been sent, the 8048 keyboard scan code signal drops to 0 (00H).

When you hold a key down for more than a half second, the 8048 generates the appropriate scan code 10 times each second.

The 8048 tells the PC keyboard input circuitry that it is ready to send a key scan code by producing a logic high on its KBD DATA line for 0.2 milliseconds. It then pumps out an 8-bit serial scan code, least significant bit first, each bit 0.1 milliseconds wide.

The KBD CLK signal from the 8048 to the system

**Table 2-7. Scan codes generated by pressing the keys of the IBM PC**

Key Number	Key Label	Scan Code	Key Number	Key Label	Scan Code
1	Escape	01	43	\	2B
2	1	02	44	z	2C
3	2	03	45	x	2D
4	3	04	46	c	2E
5	4	05	47	v	2F
6	5	07	48	b	30
7	6	07	49	n	31
8	7	08	50	m	32
9	8	09	51	<	33
10	9	0A	52	>	34
11	0	0B	53	/	35
12	-	0C	54	Shift	36
13	=	0D	55	Pt Sc	37
14	Backspace	0E	56	Alt	38
15	Tab	0F	57	Space	39
16	q	10	58	Caps Lock	3A
17	w	11	59	F1	3B
18	e	12	60	F2	3C
19	r	13	61	F3	3D
20	t	14	62	F4	3E
21	y	15	63	F5	3F
22	u	16	64	F6	40
23	i	17	65	F7	41
24	o	18	66	F8	42
25	p	19	67	F9	43
26	[	1A	68	F10	44
27	]	1B	69	Num Lock	45
28	Enter	1C	70	Scroll Lock	46
29	Ctrl	1D	71	7	47
30	a	1E	72	8	48
31	s	1F	73	9	49
32	d	20	74	-	4A
33	f	21	75	4	4B
34	g	22	76	5	4C
35	h	23	77	6	4D
36	j	24	78	+	4E
37	k	25	79	1	4F
38	l	26	80	2	50
39	;	27	81	3	51
40	,	28	82	0	52
41	'	29	83	Del	53
42	Shift	2A			

board is delayed and then clocked through a 74LS175 quad-D flip-flop (U26) as shown in Fig. 2-30 to produce a clock input to the 74LS322 8-bit serial/parallel-in register (U24). When the last bit of the 8-bit scan code has been serially shifted into U24, it produces a signal out its QH' line. This signal is felt on the data input to 74LS74 dual-D flip-flop (U82). When the next input clock signal from U26 is felt by U82, the flip-flop generates interrupt request signal IRQ1.

Interrupt request IRQ1 is sent to the 8259 programmable interrupt controller (U2), which generates an interrupt signal, INT. INT is sensed by the 8088 CPU.

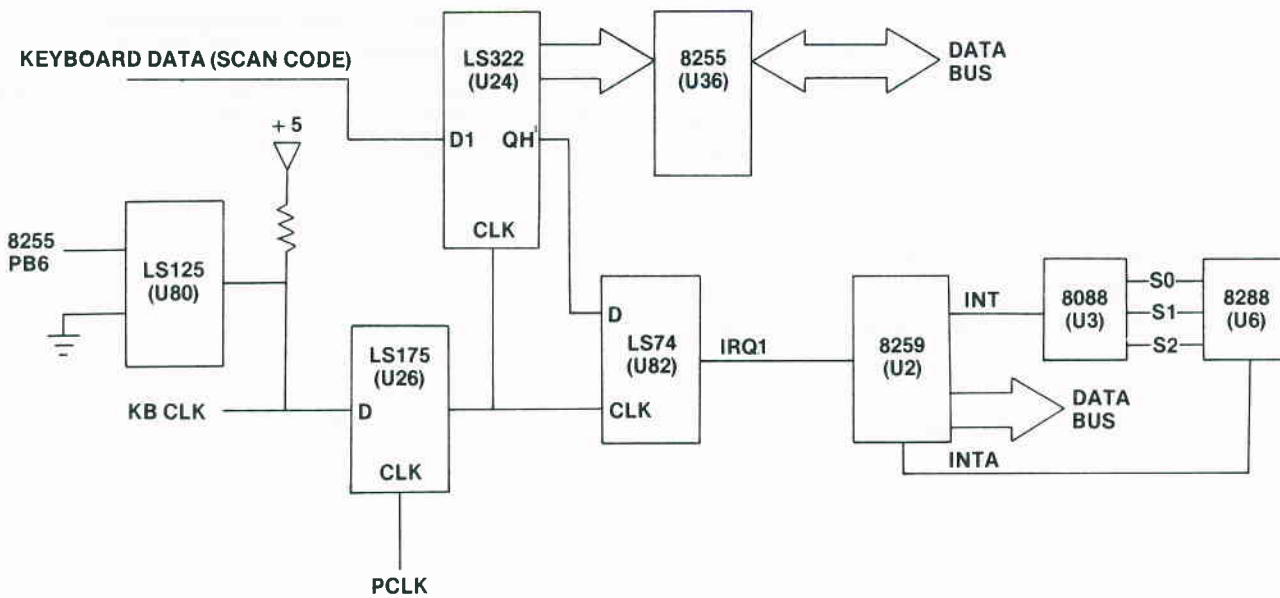


Fig. 2-30. The circuitry on the system unit that acts on each keyboard scan code.

The CPU halts what it was doing and acknowledges the interrupt request by sending a code out its S0–S2 lines to the 8288 bus controller. The 8288 responds by generating an interrupt acknowledge signal, INTA, that is sent back to the 8259 (U2). The 8259 then places an interrupt code (INT 9) on the data bus, and the 8088 CPU calls the INT 9 subroutine in the BIOS. INT 9 causes the scan code to be read into port A of the 8255 PPI (U36). The scan code is converted by the BIOS subroutine to an ASCII code for the character selected. The scan code and the character code (ASCII) are stored in a 16-character buffer. INT 9 also clears the interrupt request so another system interrupt can occur.

The ASCII character and the scan code for a single key action are read out of the buffer by another interrupt (INT 16). The INT 16 signal is called by the program or operating system. When the program you are running in your PC, or even the operating system waiting for input, requires keyboard action by you, an INT 16 is generated. It causes the BIOS to execute the keyboard I/O subroutine. Keyboard I/O reads through the keyboard buffer until it finds a character code. Then it places each code (ASCII and scan) into an 8088 register. The subroutine then reads the status of the data to determine if any special keys (Ctrl, Alt, or Shift) were pressed. Finally, it sends the ASCII character code to the calling program. The calling program uses the character as a character string or data input for its use and passes the character to the active output device (screen or printer) so you can see what character was

depressed. Through programming, this last step can be skipped so that you can't see what key was depressed. This technique is used for entering passwords.

### The Speaker

Fig. 2-31 illustrates how your speaker is able to make sounds. As shown, the speaker is software controlled. Whenever your program addresses 0061H, port B of the 8255 PPI (U36), a logic 1 in bit 1 (PB1) of the port can be used to turn on the modulating signal to the speaker. This lets the OUT 2 signal from the 8253 programmable interval timer (U34) combine with the enable from U36 in the 74LS38 quad 2-input NAND buffer (U63). The output from U63 is passed to the

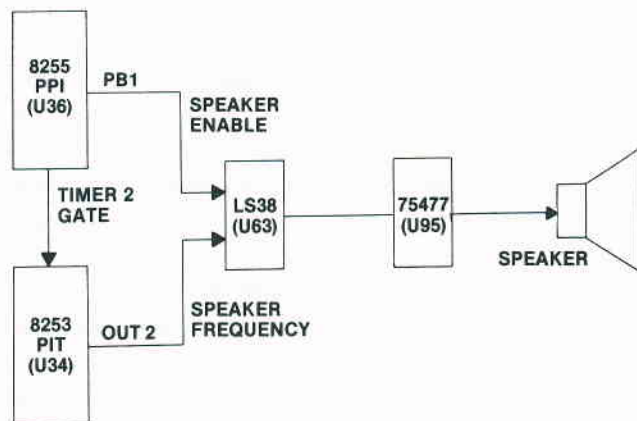


Fig. 2-31. The speaker circuitry.

75477 relay driver (U95). Each change is amplified by U95 to move the cone of the speaker in or out, producing an audible click.

By varying how often and how fast you cause these clicks, you can make your PC produce arcade sounds, music, and even crude speech. The frequency of the pulses out of the U34 timer controls the pitch (frequency) of the sound produced by the speaker. You can also control the speaker by varying the enable (ON/OFF) signal from the 8255 PPI (U36) or by varying the clock input to the 8253 timer (U34).

The range of frequencies you can generate depends on how you program your machine. If you write your program in BASIC, you can generate frequencies up to about 1000 Hz. By programming in machine language, you can easily cover the entire audio band (300 to 3000 Hz).

Your PC's BIOS ROM does not support speaker sounds. It doesn't have a general service routine stored in it that, when addressed (called by your program), will click the speaker at a certain frequency. Each speaker action must be provided by the program that is running.

### The Game Control Adapter

This interface is an interesting and useful window to the PC. It lets you connect two joysticks or up to four game paddles to the system via an adapter card that plugs into an expansion slot.

As shown in Fig. 2-32, there are eight input lines available on the 15-pin D connector on the adapter card. Four of the lines are digital inputs. The other four input lines are resistive, or analog, inputs.

A joystick connection is shown in Fig. 2-33. In the figure, two joysticks are connected to the 15-pin D connector so that the x-coordinate inputs enter on pins 3 and 11. Likewise, the y-coordinate inputs enter on pins 6 and 13. Each input is produced from a 100K variable potentiometer built into the joystick. The pushbutton, or "fire" button, inputs enter on pins 2 and 10.

Together, the resistive (xy coordinate) and pushbutton inputs form an 8-bit data word that can be read by addressing location 00201H. The input pins of the D connector can be related to the 8-bit port 201H data word as shown in Fig. 2-34.

The game control adapter circuitry is shown in Fig. 2-35. Both hardware and software are required to use the game control adapter. The software sends a triggering signal to the adapter with an OUT to port 201H (513 in decimal). The adapter circuitry responds by setting the resistance input pins (pins 3, 6, 11, and 13) to a

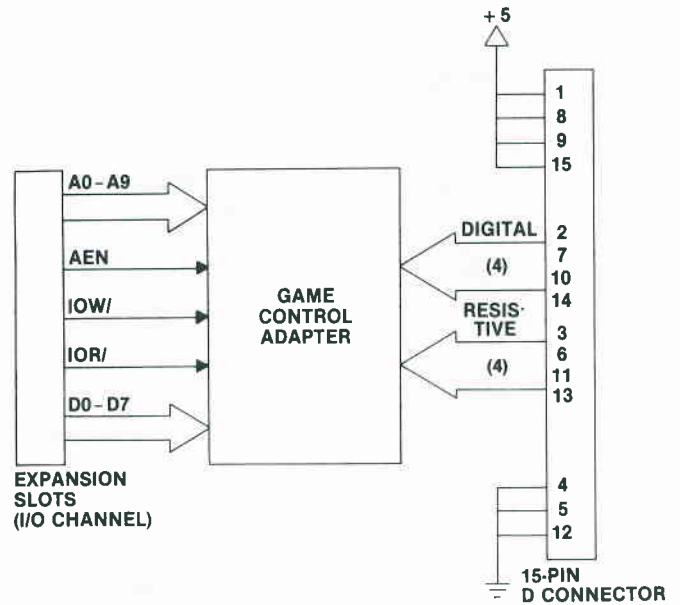


Fig. 2-32. Eight input lines connect to the game control adapter plugged into one of the expansion slots.

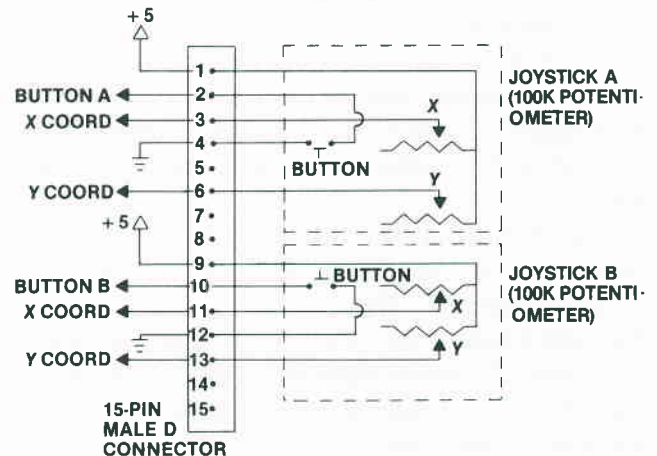


Fig. 2-33. The pin signals for connecting a pair of joysticks to the game control adapter connector.

	D CONN. PIN ASSIGNMENTS	FUNCTION	
DIGITAL INPUTS	BIT 7	14	BUTTON 2 } JOYSTICK B
	BIT 6	10	
	BIT 5	7	Y COORD } JOYSTICK B
	BIT 4	2	
RESISTIVE INPUTS	BIT 3	13	Y COORD } JOYSTICK B
	BIT 2	11	
	BIT 1	6	Y COORD } JOYSTICK B
	BIT 0	3	

(ADDRESS 00201 H)

Fig. 2-34. The relationship of pin assignments to data bus bits.

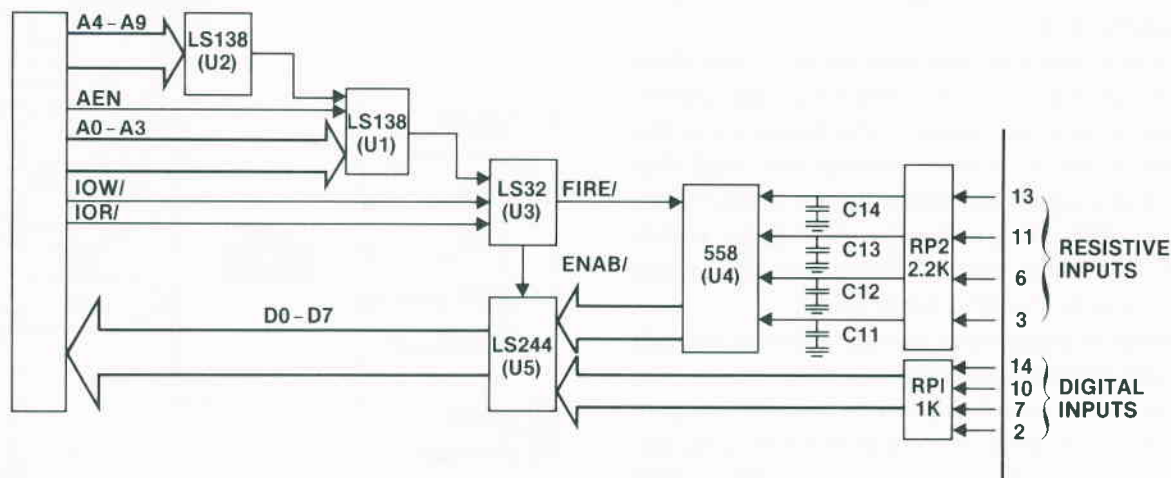


Fig. 2-35. The game control adapter circuitry.

logic 1 for a time period proportional to the amount of resistance on each of these lines.

The program performs a loop polling of port 201H to determine how long it takes for the logic 1 in each of the four connected resistive input bits to return to 0. The number of times the loop is made is directly proportional to the resistance setting in the joystick (or paddle).

The value of resistance set on the 100K ohm potentiometer (pot) in one analog input is part of a timing circuit composed of the 100K ohm pot, a resistor, a capacitor, and a part of the NE558 quad timer (U4). U4 is simply four 555 timers together in one chip package. When the 558 is triggered by addressing 00201H, all four outputs from it are set HIGH and the timing circuit begins to count down. This level remains HIGH for a time period determined by the setting of the potentiometer for each paddle.

A routine in the game program can repeatedly check to see if the timer output is still HIGH. It does this by reading address 00201H (IN 00201H). When it does so, the 74LS244 tri-state octal buffer (U5) places a byte of information on the data bus. The logic levels of each of the four lowest bits in this byte can be read by the program. These levels represent the state of each timer output of U4. A bit is HIGH or 1 as long as the timer is counting down. A counter in the program keeps track of how many times the timer is checked before its output changes to LOW, or 0.

When a 0 is read, the program stops counting at a value (between 0 and 255) directly proportional to the setting of the paddle potentiometer.

Pushbutton switches can also be read using the same technique. In this case, the upper four bits of the 8-bit data word can be read by the program. If a bit is LOW (logic 0), that pushbutton has been depressed. Likewise, a 1 in this position means that the button is open (not depressed).

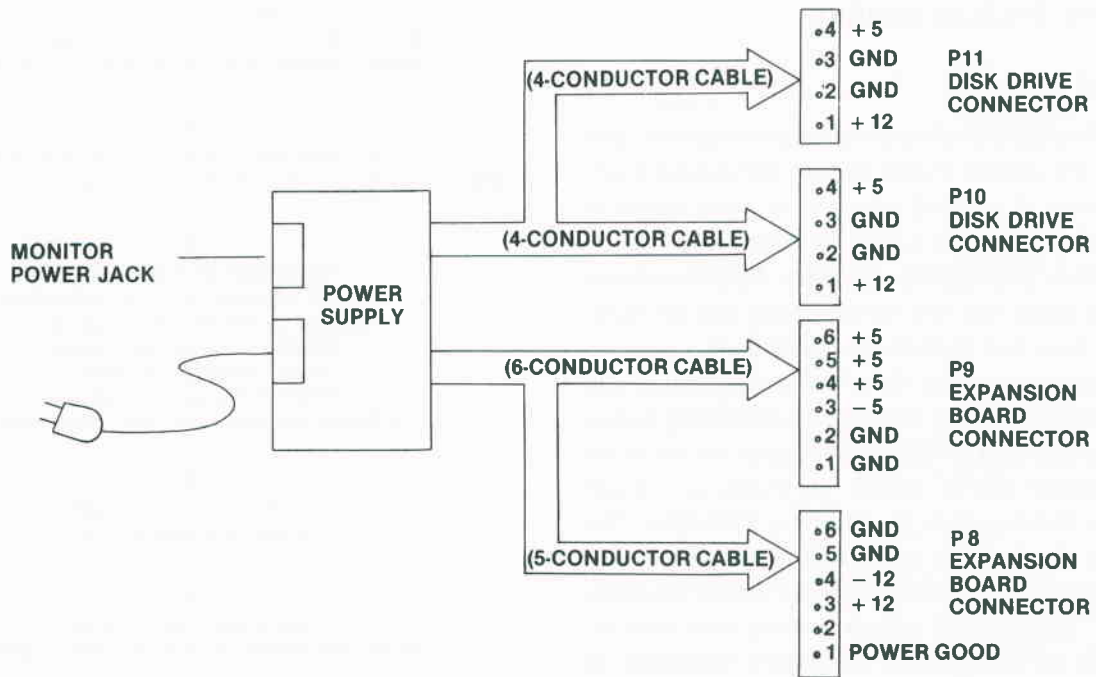
In this manner a program can loop through a subroutine to continuously monitor the pushbuttons. The program can be written to act only when a button has been depressed.

Keep in mind that these pushbuttons are not "debounced." When you press a button, the switch will likely bounce several times before it settles down, so the computer must take several readings of each switch input (using IN 00201H) before acting on the switch closure.

## THE POWER SUPPLY

As described on pages 1-24 through 1-27 in the *IBM PC Technical Reference Manual*, a switching power supply provides four voltages to the PC circuitry: +5.0 volts, -5.0 volts, +12.0 volts, and -12.0 volts. The maximum power dissipation is 63.5 watts, less than that of a 100-watt room lamp.

The switching power supply is described in Fig. 2-36. The +5.0 volts is used by the logic chips on the system board, the disk drive electronics card, and the adapter cards that are installed in the expansion slots. The -5.0 volts is used in the dynamic RAM chips. The +12.0 volt supply is used by the dynamic memory chips and the disk drive motors. Both +12.0 volts and



**Fig. 2-36.** The power supply circuitry.

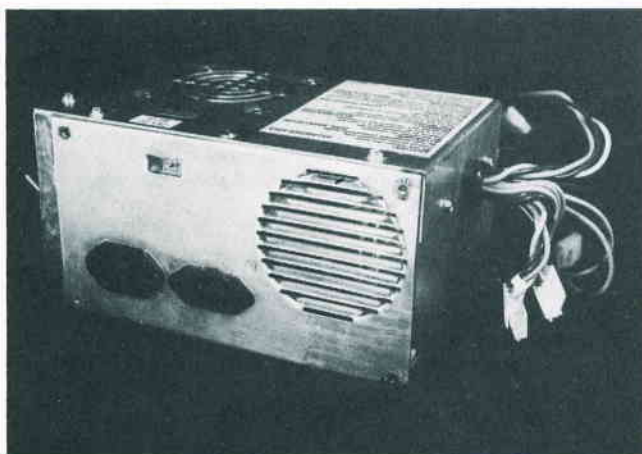
- 12.0 volts are available to power the circuitry on the communication adapter card. All of these voltages are available on the I/O connectors, expansion slots J1 through J5.

The switching power supply is enclosed in steel and has a cooling fan mounted directly under its top cover as shown in Fig. 2-37. It has a built-in circuit breaker that automatically resets in a few seconds after the breaker has tripped.

The female connector in Fig. 2-38 provides power to the IBM monochrome display unit.

Because power supplies rarely fail and because this

guide avoids getting you into or around high-voltage circuits, I won't discuss troubleshooting the power supply. It is best to leave power-supply problems to an experienced repair technician. IBM discourages anyone from troubleshooting the switching power supply except experienced, IBM-trained technicians. The reference manual does not even provide schematics or detail on the design and operation of the power supply.



**Fig. 2-37.** The IBM PC power supply.



**Fig. 2-38.** A special connector provides power to the IBM monochrome display unit.

## HOW THE SYSTEM WORKS

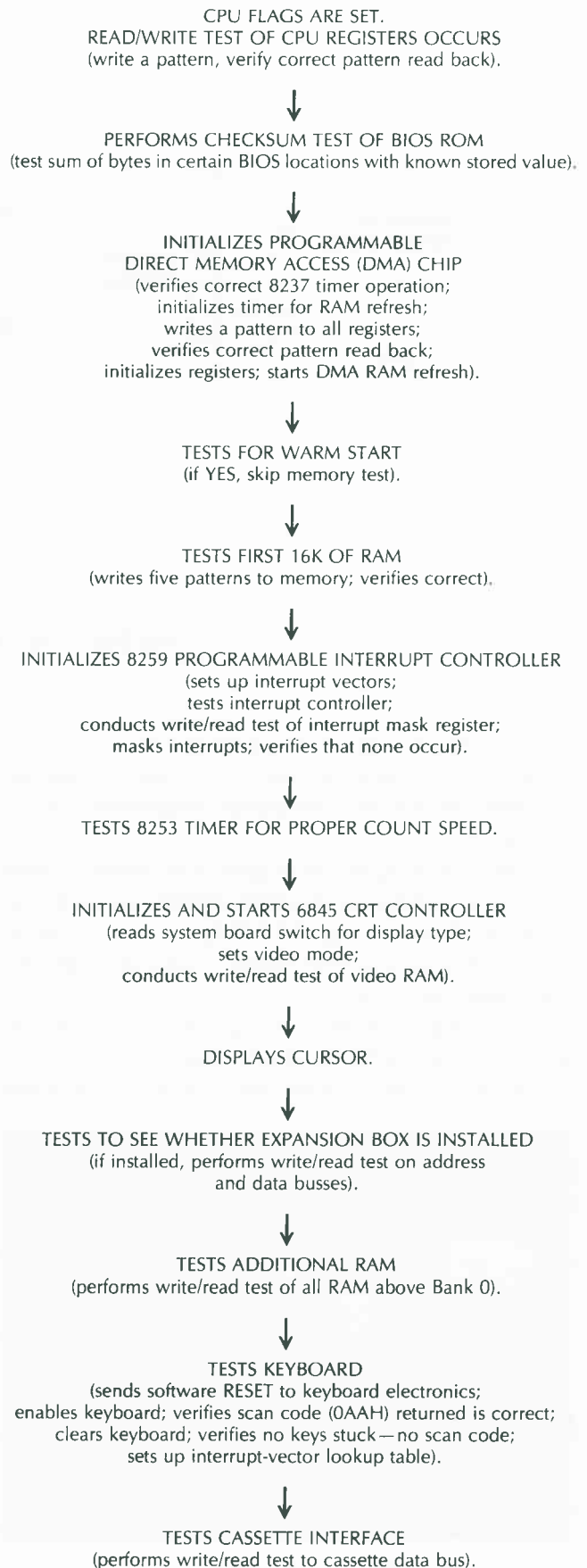
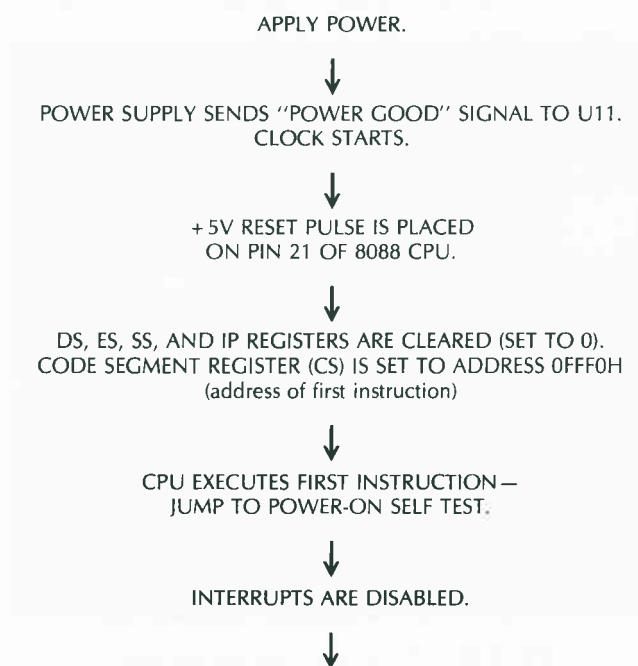
### Cold Boot

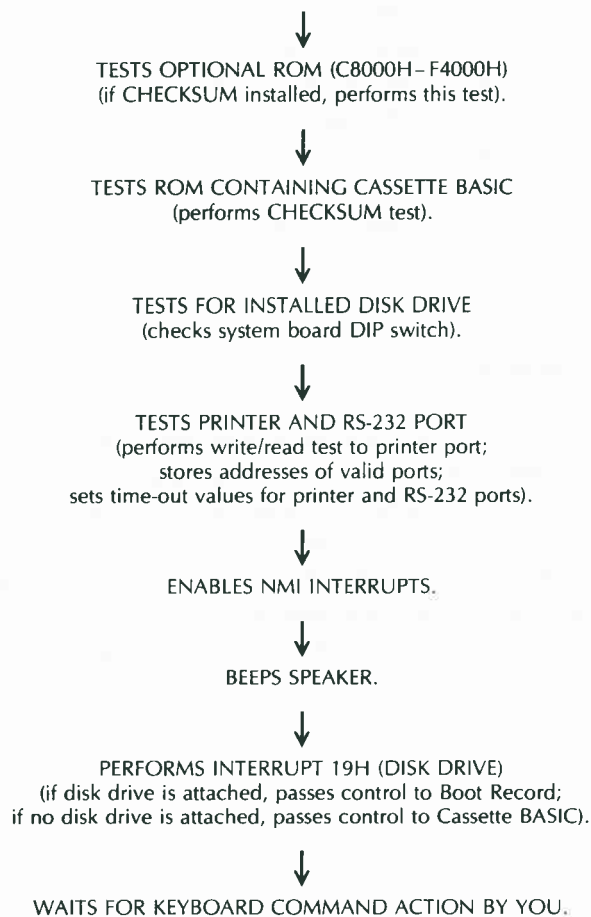
When you turn on the power to your monitor, and then press the rocker switch to turn the machine on, your PC beeps at you and asks you to insert a disk in drive A. When you slip a disk into the drive, gently close the door, and depress the Enter key, the screen flashes and prints out the familiar IBM sign-on statement. You have just performed a cold boot.

What does it mean to "boot up" a disk? When you first apply power to your IBM PC, the switching power supply puts out a POWER GOOD signal to the 8284 clock generator (U11), which generates a +5-volt RESET pulse that is sent to pin 21 of the 8088 CPU. This signal starts the boot-up routine. It's called a "cold" because the system was not energized before the boot, and "boot" because the system is being reset and initialized with all the start-up conditions necessary to operate and enable the man-machine communication interface (the word "boot" comes from "bootstrap," and refers to the computer's pulling itself up by its own bootstrap). The bootstrap in your IBM PC is in the BIOS ROM. It is a program-starting program, so to speak.

The following flowchart shows the actions that occur in your IBM PC during a cold boot, from the time you turn on the power.

#### THE POWER-UP PROCESS





The rest is up to you. The system will sit and wait until your interaction with it via the keyboard tells it what to do. The PC has beeped at you and the disk drive may be spinning. If you have a system disk in the drive, the Boot Record is loaded into memory. The Boot Record is a simple, short program found on Track 0, Sector 1 of each program disk. It loads the IBMBIO.COM and IBMDOS.COM programs into RAM. These are hidden programs, which, with the ROM BIOS, form the basis of the disk operating system (DOS). You will be prompted for the date and time, and then the following message will appear:

The IBM Personal Computer DOS  
Version 2.00 (C)Copyright IBM Corp  
1981,1982,1983

The message will be slightly different if you are using a different version of DOS.

If you don't have a disk drive installed or didn't have a system disk in your drive when you pressed ENTER, the BIOS will automatically default to ROM-based Cassette BASIC and await your keyboard com-

mand. With Cassette BASIC, you will receive this message:

The IBM Personal Computer BASIC  
Version C1.00 Copyright IBM Corp 1981  
62940 Bytes free

## Warm Boot

During the bootstrap operation, the BIOS monitor checks to see whether the system had been energized and was being used when the RESET pulse occurred. If indeed it had been powered up, all of the RAM tests described for a cold boot are bypassed.

Holding the Ctrl and Alt keys down and then depressing the Del key generates a nonmaskable interrupt (NMI). This causes a system reset to initial conditions. The Power-On Self Test (POST) is performed, but the RAM tests are bypassed.

## SOFTWARE STRUCTURE

Three types of software are supplied with your disk drive IBM PC computer system:

- The system monitor
- BASIC high-level language
- The disk operating system (DOS)

The **system monitor** lets you initialize your computer and enables it to receive keyboard entry and to generate screen display. The system monitor resides in the BIOS ROM.

Each IBM PC comes with the **high-level language** Cassette BASIC stored in ROM. BASIC is an *interpreted language*. Each instruction is read, interpreted, converted to machine language code, and acted upon before the next instruction is read, and so on. In contrast, with a *compiled language* such as FORTRAN, all the instructions are read, interpreted, and converted into machine language before any are acted upon. Compiled-language programs run faster than interpreted-language programs. However, BASIC is a popular programming language because it is simple to learn. Several youthful entrepreneurs have become millionaires writing useful software in BASIC.

In addition to ROM-based Cassette BASIC, two extended versions of BASIC are available on the DOS disk. These programs complement and enhance the Cassette BASIC commands.

The third ingredient for a complete software system

is a unique software package designed to control the way the computer communicates with peripheral equipment and other software programs. This package is called an **operating system**. Some of the operating systems in use in microcomputers today are DOS, PRO-DOS, MS-DOS, PC-DOS, TRS-DOS, RTX, CP/M, and CP/M-86.

On the IBM PC, your operating system is called *PC-DOS*, for Personal Computer Disk Operating System. You can also use Microsoft's MS-DOS. Both control programs came from the same beginnings. Your IBM PC disk operating system (PC-DOS) handles reading and writing disk-stored information and lets you format disks, copy disks, and even catalog the programs or files you've saved. PC-DOS is loaded into the PC's RAM by booting the system up with a disk containing the operating system. PC-DOS uses approximately 10K of RAM.

Sometimes neophyte programmers forget where

PC-DOS is stored and inadvertently write programs that store different values in the DOS-reserved area. This changes the values in DOS, which causes trouble—usually at the most inopportune time.

A multitude of applications programs are available for the IBM PC. In reality, the software makes the machine, and many new and exciting software packages for the IBM PC are coming to market each month.

## SUMMARY

In this chapter you've learned the basic parts of a computer and how the hardware of your IBM PC works. You saw that memory, I/O, and the CPU all perform vital functions in this computer system. You learned what happens inside the IBM PC when you turn power on. And you learned that several kinds of software are required to make your PC a functioning system.

# Basic Troubleshooting

---

**L**ike automobiles, computers break down after lots of use. Some break down sooner than others. Finding out what broke can be easy or difficult, depending on your understanding of how to analyze a problem, identify the failed part, and step toward the correct repair. This chapter will show you how to find problems in your IBM PC in the shortest amount of time.

## INTRODUCTION TO TROUBLESHOOTING

Imagine for a moment that you're in the midst of printing a lengthy analysis report when suddenly the printer halts, the screen display goes blank, and your IBM PC ceases to function. What do you do? What failed?

This chapter is devoted to a subject we often wish we could pass off or ignore—trouble. Trouble is like a flat tire: no one wants one, but when it occurs we all wish we could fix it quickly and get the experience behind us. Knowledge and action are required to overcome trouble.

You know from reading the owner's manual that came with your computer, that it's a digital machine; it operates in binary, where every condition is either true (logic 1) or false (logic 0). A digital computer such as the IBM PC generally doesn't break down slowly, with

graceful degradation you can see. If it fails, it's usually with a hard, consistent failure.

The digital devices that make up your IBM PC function within strict rules of logic. The most effective way to respond to a failure in these devices is to think the problem through just as the machine operates, logically. Understand what should be happening and compare the "shoulds," one by one, with what is really happening.

An interesting deductive technique called *troubleshooting* is particularly appropriate for solving digital equipment failure problems. But troubleshooting could be a really frustrating experience if you were left to struggle through the process by yourself without a good guide. This book provides you with techniques for quick and easy troubleshooting and repair.

## Steps To Successful Troubleshooting

Effective and efficient troubleshooting requires gathering clues and applying deductive reasoning to isolate the problem. Once you know the cause of the problem, you can follow a process of analyzing, testing, and substituting good components for each suspected bad component to find the particular part that has failed.

The use of special test equipment such as logic probes and logic clips can speed the analysis process,

but for most failures brain power by itself will suffice. Once the problem has been isolated to a particular group of chips, deductive analysis changes to intelligent trial-and-error replacement. Reducing the number of suspected chips to just a few and using intelligent substitution is the fastest way to identify the faulty device in the least amount of time.

In general, you can follow these steps to success when your computer fails:

1. Don't panic.
2. Observe the conditions.
3. Use your senses.
4. Retry.
5. Document.
6. Assume one problem.
7. Diagnose to a section (fault identification).
8. Consult the symptom index (error code interpretation and problem matching).
9. Localize to a stage (fault localization).
10. Isolate to a failed part (fault isolation).
11. Repair.
12. Test and verify.

The steps to troubleshooting success are discussed in detail later in this chapter.

## The Troubleshooting Process

Every computer is composed of the functional sections shown in Fig. 3-1. Any of these sections can fail.

When something goes wrong, the first step is to determine whether the trouble results from a component failure or just a loose connection or human error. Once you're sure a failure has occurred, the next step is to determine which functional section of the system

is not operating—disk drive, keyboard, display, or some other part.

Then, step by step, break each section up into stages and try to track the trouble to a single component. If a display isn't working, for example, the problem could be in the display monitor itself, in the video cable, or in the video circuitry of the computer. Each of these can be considered a stage of the video display functional section.

Next, to troubleshoot your computer, you need to recognize the components of your IBM PC and understand how it interacts with the other parts of the system.

## COMPONENT RECOGNITION

What's an IBM PC made of? Let's take a look.

That strong housing, or case, and the detachable keyboard are made of high-strength, flame-retardant molded plastic. These cases are not likely to fail under normal use. The trouble is much more likely to come from inside the cases.

**Make sure the power is off** and open your IBM PC computer. Use the disassembly instructions found in the Appendix.

There are a number of subassemblies inside your computer, including the system board, or motherboard, the disk drives, the input/output unit, and the power supply. Let's concentrate on the system board, since this is where most failures occur.

The motherboard (shown again in Fig. 3-2) is made of fiberglass and has many colorful devices mounted on it—sockets, connectors, and wire traces embedded into the board, integrated circuits (or chips), resistors, capacitors, and transistors.

Fig. 3-3 shows the types of devices that you will find mounted on the motherboard. The values indi-

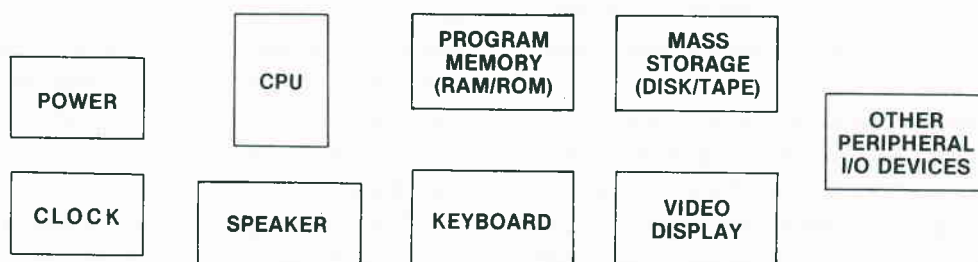
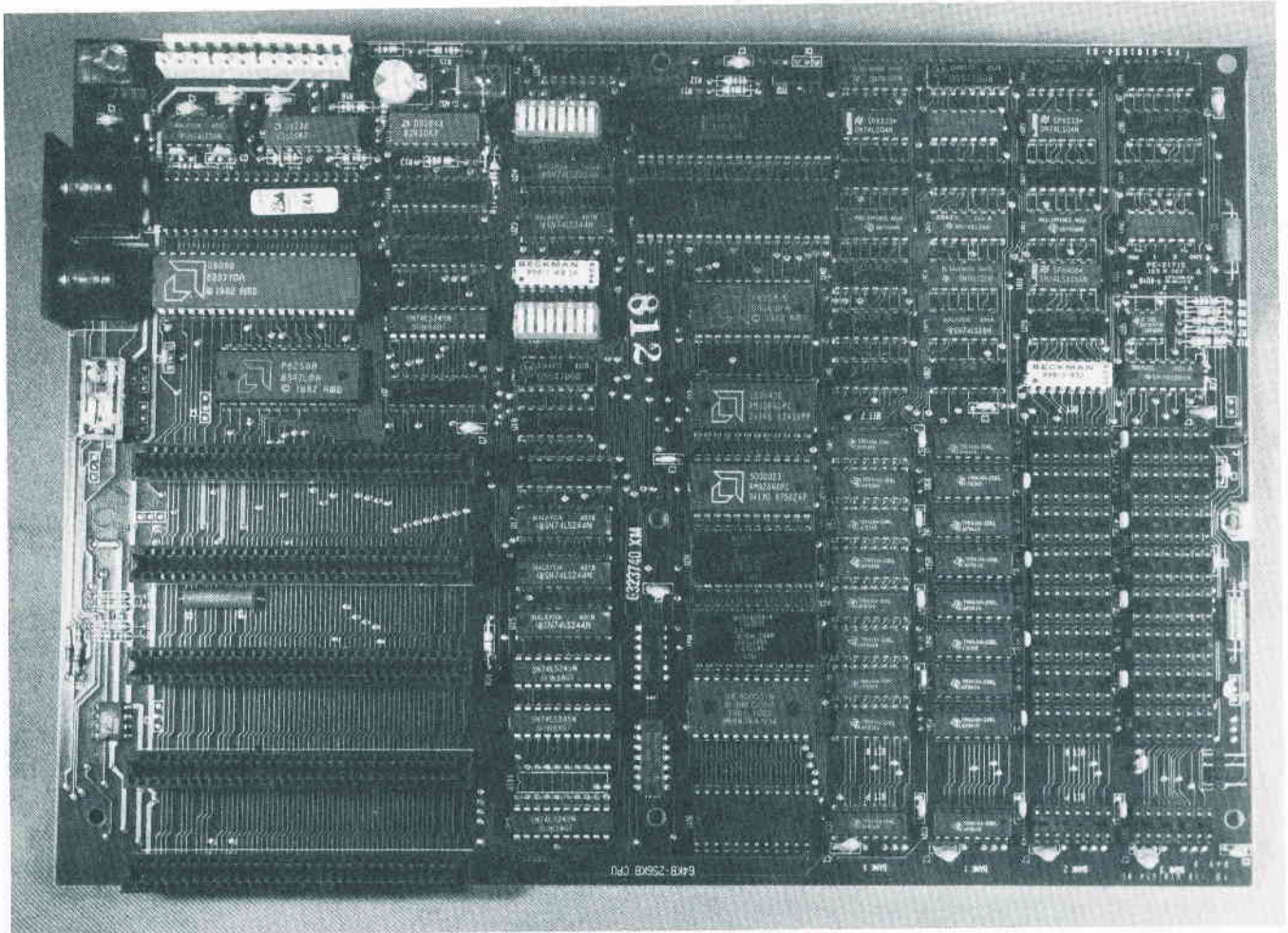


Fig 3-1. The functional units of the IBM Personal Computer.



**Fig. 3-2.** The IBM PC system board.

cated in the figure are the actual values of components on the IBM PC system board or the color/graphics adapter board.

## Chips

Those black-cased, centipede-looking things are the *chips* (see Fig. 3-3A). They serve the function of hundreds of transistors (or vacuum tubes, the predecessors of transistors), and cause the computer to work logically. The IBM PC is a Von Neumann machine: it works in binary digits (bits). All conditions are either ON (logic 1) or OFF (logic 0), and all operations occur in sequence. Dr. John Von Neumann first described his idea of a binary computer in 1945.

There are eight sizes of chips on your motherboard: 8-pin, 14-pin, 16-pin, 18-pin, 20-pin, 24-pin, 28-pin, and 40-pin. The ROMs in your IBM PC are custom chips. IBM placed some of these chips in

sockets, so repair is quick and easy with no unsoldering and resoldering.

Notice how each chip has a notch or groove at one end as shown in Fig. 3-4. This notch marks the end of the chip where pin 1 can be found. Pin 1 is to the left of the groove as you look down upon the top of the chip with the groove pointed away from you. The pins are numbered counterclockwise starting from pin 1, so that the highest-numbered pin is directly across from pin 1. As you'll learn later, in chip replacement you must insert the new chip into the socket with pin 1 in exactly the right place.

Chips have special markings that tell a lot about what's inside. Look at the printing on the tops of the chips on your IBM PC's motherboard. First, you'll notice that many different companies make chips, and that some of these companies are outside the United States—in Brazil, El Salvador, Indonesia, Korea, Malaysia, Mexico, Singapore, and Taiwan, for example. Most companies place their logo on the chip. Some of

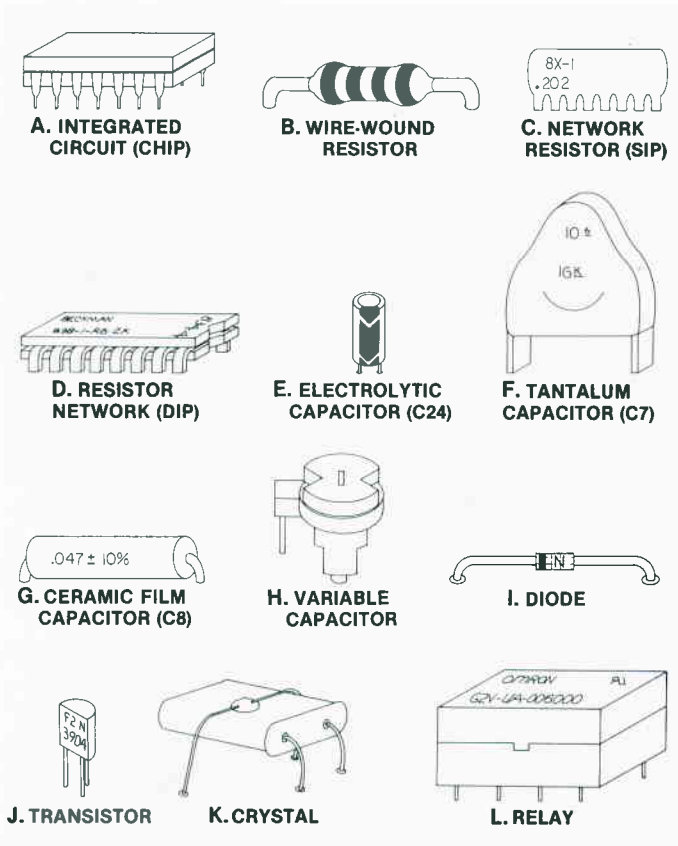


Fig. 3-3. The types of devices found on the system board.

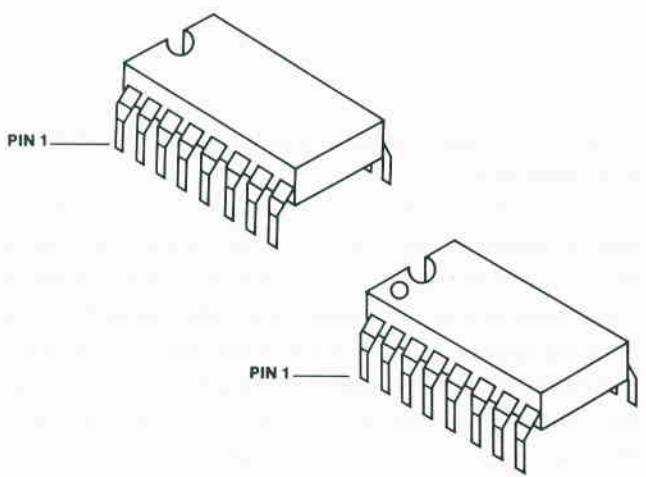


Fig. 3-4. Locating pin 1 on integrated circuits (chips).

the logos represented on your IBM PC chips are shown in Fig. 3-5.

You'll also notice letter-number combinations on the chips. Some chips have two sets of letter-numbers. One set identifies the type of device, and the other set tells when the chip was made. The first, or primary, set

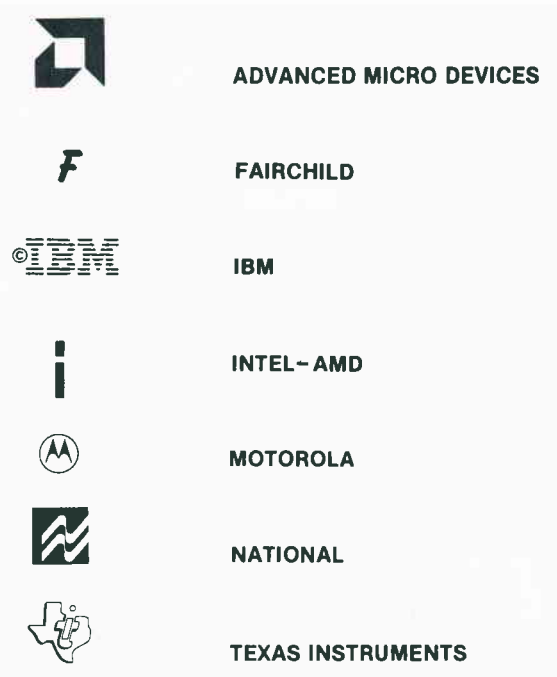


Fig. 3-5. Representative logos that can be found on chips mounted on the system board.

of letter-numbers is called the *manufacturer's type number*, or *manufacturer's device code*. It appears in three sections as shown in Fig. 3-6.

The prefix ("DM" in DM74LS125AN) is usually used to identify the manufacturer, although sometimes it is used to identify the device family (also associated with a manufacturer) or a temperature range (N = commercial temperatures, S = military temperature requirements). The prefix is sometimes omitted. In Fig. 3-6, the DM represents the National Semiconductor company.

The core number is three to six digits long with a letter or letters in the middle. It indicates the basic logic family. Most of the chips in the IBM PC are of 74xx series; these chips use TTL logic (transistor-transistor-logic). The core number 74LS125 represents a quad tri-state buffer. The letters in the middle of the number describe particulars about the logic used in the chip, such as speed or power. In Fig. 3-6, the LS stands for *low power Schottky*, a particular type of TTL logic design.

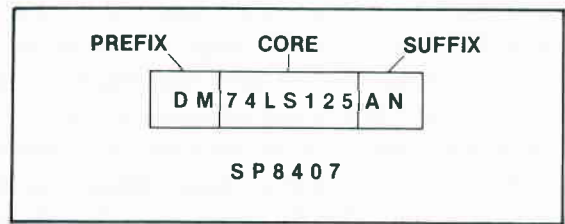


Fig. 3-6. A representative manufacturer's device code.

The suffix represents the package type or temperature range. Usually it describes the package type. In Fig. 3-6, the AN denotes a dual in-line package (DIP), a type of chip. Other package types include the flat-packs, single in-line packages (SIPs), and leadless chips.

The second letter-number combination on a chip varies with the manufacturer and the year and week the chip was made. For example, the SN74LS245N (U12) is a tri-state octal transceiver made by Motorola. Numbers such as 8407 are printed below the manufacturer's device code. The number 8407 represents the seventh week in 1984, the date of manufacture of this chip. Likewise, a chip at U27 on the IBM PC motherboard marked 74LS74 and 8347 is a quad 2-input NOR gate manufactured by Fairchild in the forty-seventh week of 1983.

All the chips on the IBM PC motherboard are listed in the Appendix.

## Resistors

The three types of *resistors* found in the IBM PC circuitry are shown in Fig. 3-3B, C, and D. Resistors are used to restrict or limit the flow of electrical current through the board's circuitry. One type of resistor is the cylindrical wire-wound device shown in Fig. 3-3B. The value of resistance is given in ohms, and can be determined by comparing the color bands with the colors in Table 3-1.

**Table 3-1. Resistor color code chart**

Color	Digit	Multiplier
Black	0	1
Brown	1	10
Red	2	100
Orange	3	1000
Yellow	4	10000
Green	5	100000
Blue	6	1000000
Violet	7	10000000
Gray	8	100000000
White	9	1000000000
Gold	± 5% tolerance	
Silver	± 10% tolerance	

For example, R1, located just above the expansion slots on the system board, has the color code brown-gray-yellow-gold. The first two bands describe the primary number (18). The third band represents the number of zeroes to add to the primary number—in this case four. The last band is the tolerance value, or

how close to the color band value the actual value must be. The gold band represents a 5 percent tolerance value. Thus, by using Table 3-1, we find R1's value to be 180,000 ohms (180K ohms); the actual resistance value is  $\pm 5$  percent. This matches the value given on schematics of the IBM PC.

A recently developed electronic device, the *resistor network*, is actually a group of resistors built into a single in-line package (SIP) or a dual in-line package (DIP) (see Fig. 3-3C and Fig. 3-3D). Several SIP resistor networks are mounted on the board. These resistors are designated RNxx or RMxx.

Fig. 3-3C shows an SIP network resistor like the one labelled RM1 located at the top left end of the color/graphics card. Resistor network RM1 is used by several components on the board at the same time.

The resistor shown in Fig. 3-3D is a DIP network resistor, RN2, located near the right end of the third row of chips on the system board.

The resistance designation of a network resistor is printed on the side of its package. RM1 on the color/graphics card is marked 8X-1 202. The 202 is a key to the resistance value in ohms. The first two numbers (2 and 0) are the significant figures. The third number (2) tells how many zeroes to add to the significant figures. Thus, 202 means 20 plus 2 zeroes, or 2,000 ohms (2K ohms).

Some network resistors, such as RN2, are marked directly with their resistance value. RN2 on the system board is marked 898-1-R8.2K. The "8.2K" labels this resistor network as a group of 8.2K ohm resistors.

## Capacitors

In addition to chips, your motherboard has mounted on it a number of devices called *capacitors* (Fig. 3-3E, F, G, and H). Capacitors receive and store an electric charge. They come in four varieties: (a) electrolytic, (b) tantalum, (c) ceramic film, and (d) variable. All four types of capacitors can be found on the IBM PC motherboard and the color/graphics card.

Capacitors are measured in fractions of farads. You'll see values listed in "Mfd" (for microfarads) and "p" (for picofarads). *Micro* means "to the sixth decimal place" or 0.000001 (one millionth), and *pico* means "to the twelfth decimal place" or 0.000000000001 (one trillionth). Thus 0.022 microfarads means 0.000000022 farads, and 47 picofarads means 47 trillionths of a farad.

Capacitor (cap) value identification is one of the most challenging tasks you can encounter because

most companies like to use their own identification standards. On the side of tantalum capacitor C7 located in the middle of the upper two-thirds of the system board are the numbers "10<sup>6</sup>" and "16K." This means that C7 is a 10-microfarad capacitor and is rated at 16 volts.

Ceramic film capacitor C8 between the J3 and J4 slots on the system board has the value ".047 ± 10%" stamped on it. It's easy to see that this is a .047 microfarad capacitor. Other ceramic film capacitors are color-banded. These can be decoded using the color chart in Table 3-2. They have two more color bands added that refer to the capacitor's temperature dependence and tolerance. Capacitance varies with temperature (and to some extent with the cap's size and the applied voltage). The temperature dependence of the capacitance value is given as the coefficient parts per million per degree Celsius (PPM/C). Tolerance defines how much variation is permissible between the actual value of the capacitance and the nominal capacitance value.

**Table 3-2. Capacitor color codes indicating capacitance in picofarads.**

Color	Digit	Multiplier	Tolerance
Black	0	1	
Brown	1	10	
Red	2	100	
Orange	3	1,000	
Yellow	4	10,000	
Green	5	100,000	
Blue	6	1,000,000	
Violet	7		
Gray	8		
White	9		10%
Gold			5%
Silver			10%

An electrolytic capacitor has a polarity marked on its case. Usually, the negative pole is indicated with an arrow marking. Electrolytic capacitor C24 on the color/graphics card has a rating of 4.7 microfarads.

At the right side of the system board is a variable capacitor used to adjust the color signal. It does this by changing the frequency of the basic system clock in the 8284 clock generator chip. This capacitor can be varied between 5 and 30 picofarads.

## Diodes

Diodes are tiny, usually glass devices shaped like resistors (Fig. 3-3). They permit the flow of electrons in

only one direction. Diodes are marked with printing on the side (although most of the time you'll have a tough time reading it). There are several diodes on the motherboard. The key to determining whether the device in question is a diode is the glass construction and the label on the side. A 1Nxxxx label denotes a diode. Look at D1, located at the top of the system board—it's right above the expansion slots. D1 is called a "type FC" diode. This classifies it as a standard diode, much like a 1N4001 diode. D1 is part of the voltage regulation circuitry for the cassette DATA IN signal being applied to the input port of the 8255 PPI.

## Transistors

The half-moon-shaped device on the color/graphics card is a *transistor*. Transistors are small, semiconductor-based devices that control the flow of electricity. The key to recognizing a transistor is its 2Nxxxx designator. Fig. 3-3J is a drawing of the transistor at Q1. On the side of it is printed F2N3904. The 2Nxxxx label tells us it's a transistor. We can look up this transistor in a parts catalog and find that the 2N3904 transistor is a general purpose device.

## Crystals

A crystal is a device that vibrates or oscillates when a voltage is applied across two of its input leads. The shiny metal can on the right edge of the motherboard next to U26 is a crystal. The oscillation frequency of a crystal is determined by the physical characteristics of the crystal material inside the metal can. The can acts as a shield for stray electrical signals. Crystal X1 (Y1 on some boards) oscillates at 14.31818 MHz. This frequency is reduced by circuitry on the motherboard to produce the various clock signals used in your IBM computer.

## Relays

A relay is an electromagnetic or solid-state device that isolates sensitive circuitry (such as your PC's motherboard) from different or higher-voltage circuitry (such as cassette motor circuitry).

At the rear of the IBM PC motherboard, to the right of slot 5 and outside the 8259 programmable interval timer, is a rectangular device called relay K1. It is used to control the MOTOR ON/MOTOR OFF signals in a cassette recorder if one is connected to your PC. A signal on the motherboard passes through K1, causing its output contacts to close, turning on the cassette recorder motor just as though a switch had been flipped. The relay acts as an electrically controlled switch.

## Replacements

When you check the electronic parts catalogs, you'll find that the components presented here have prices that will pleasantly surprise you. Since 95 percent of microcomputer failures are chip failures, introducing the capacitors, resistors, diodes, and transistors serves only to familiarize you with what is on your IBM PC motherboard. These devices are soldered into the board and can be replaced only by those experienced in repair. Chip replacement is probably as far as you'll want to go in computer repair. You should probably let a repair technician replace the soldered-in components.

## COMPONENT FAILURES

While the use of troubleshooting equipment makes it easier to analyze and isolate different computer problems, many failures can be found without expensive equipment. In fact, troubleshooting and repair can be relatively simple if you understand how electronic components fail.

Failures generally occur in the circuits that are used or stressed the most. The most frequently used chips include the RAM and ROM memory chips, the 8088 CPU, and the input/output (I/O) chips between the motherboard and the disk drive. The CPU is a highly reliable device and doesn't fail very often. Most failures involve the other chips. Except for the ROM chips, which are programmed by IBM, most of these other chips are standard, off-the-shelf devices and are so common they've earned the nickname "jelly beans" — inexpensive, easy-to-replace products.

Transistors and diodes fail by disconnecting inside, which causes an open, or break, in the circuitry, or by having their output shorted. Either kind of failure causes a total loss of signal.

Capacitors fail when they short internally or when one of the leads disconnects, causing an open circuit. Again there is a loss of signal.

Resistors can absorb too much current and actually bake. The result is usually an open circuit with shorting during the "melt-down."

All of the devices mentioned so far are solid-state components. They are constructed of materials (metals, plastics, oxide, etc.) that change as the components age or are subjected to severe temperatures or high voltages. Such a change can cause the device and the circuit or system to behave strangely. Fortunately, IBM PC motherboards are not subjected to high voltages. But they can get pretty hot (especially if you fill

the expansion slots with adapter cards), and this will affect the operation of the components. When we use our computers we place the circuitry, and especially the chips, under a lot of stress. First they heat up when we turn on and use the computer. Then they cool down when we turn the machine off. Then they reheat when we turn the machine on again. This hot-cold-hot effect puts a great deal of thermal stress on the circuits. The thermal stress can cause a break in the connection of a wire leading from inside the chip to a pin, producing an open circuit, which requires chip replacement.

Even if there is no break in the chip or lead connection, after exposure to high voltages or temperatures, the operating characteristics of a device can change. A chip may work intermittently or simply refuse to work at all. An output can become stuck at 1 or stuck at 0, regardless of the input signal. Theoretically, a wear-out failure like this won't occur until after several hundred years of use, but we shorten the life span of the chips by placing them in high-temperature, high-voltage, or power-cycling environments that cause them to fail sooner.

Other problems occur outside the chip — between the chip leads and the support structure pins that connect the device to the rest of the computer through the socket. Such failures include inputs or outputs shorted to ground, pins shorted to the +5-volt supply, pins shorted together, open pins, and connectors with intermittent defects. Most commonly, trouble results from opens or shorts to ground. Chips fail far more often than diodes or transistors, because the chips that are the same size as single (discrete) diodes or transistors contain many tiny circuits that produce more heat and therefore more thermal wear.

Chapter 5, "Routine Preventive Maintenance" tells more about heat effects. If you keep your computer cool and clean, it should work well for many years.

## HOW DISK DRIVES FAIL

Disk drives give us the ability to save and load software at almost unbelievable speeds. These "boxes" are some of the most complex collections of electronics and mechanical hardware ever constructed. Thousands of tiny magnetic signals are stored on each disk that is placed into one of these drives. We expect disk drives to save all of our programs and data accurately and quickly and to accurately load the information back into the IBM PC without a single lost number or letter.

And they do. Disk drives will give us months of faultless service if we do our part, operating them carefully and providing tuning and periodic cleaning.

But sometimes we forget. We operate our drives as someone nearby puffs on a cigarette, tapping ashes onto a tray at the side of the drive. We smile as we jam a disk into the drive and then slam the drive door closed. And then one day, that horrible DOS ERROR message appears and the drive "gives up the ghost." Now what? What kinds of failures can occur with disk drives?

One type of failure is a change in the drive rotation speed, which affects the reading and writing of information on the disks. The speed is adjusted for approximately 300 revolutions per minute—200 milliseconds per revolution. As the speed varies from this optimum, disk read and write errors begin to occur.

Rough handling during disk insertion and removal can cause misalignment of the read head. Misalignment is not easy to fix. It usually requires special software and alignment tools.

## HOW DISPLAYS FAIL

Monitors are like television sets. And you know from experience that sooner or later your TV will develop a problem and need repair. Part of the reason displays still fail is that they are the only new electronic devices that still use vacuum tubes. The cathode ray tube (CRT) is the screen you look at when you work with your computer. It displays video information. The CRT is probably the only modern electronic component that is guaranteed to wear out.

The letters and numbers you see on your screen are displayed there by electrons striking the back side of the screen. The electron streams get weaker as the CRT ages. You can correct some of the effects of age, but others require a service center, since it's better not to open up the display unit and expose yourself to those dangerous high voltages.

Here are some possible video display failures:

1. *Short inside the CRT*—can result in a "hum" noise and a bar across the screen, very poor contrast, a bright beam on the screen, or even diagonal lines on the screen.
2. *Open or disconnected circuit inside the CRT*—no characters are displayed on the screen.
3. *Center of the CRT has worn*—bright, "bloomy" letters, poor intensity control; caused by tube age. You can get normal brightness with the intensity turned down as far as possible, but black is very black, and gray shades are poor or not displayed.
4. *Deposit on the inside of the screen*—screen edge won't display, reduced brightness and fuzzy display.
5. *CRT worn out*—No picture; brightness and intensity controls have no effect.
6. *Dust and dirt inside chassis*—marginal performance; display monitor performance less than optimal.

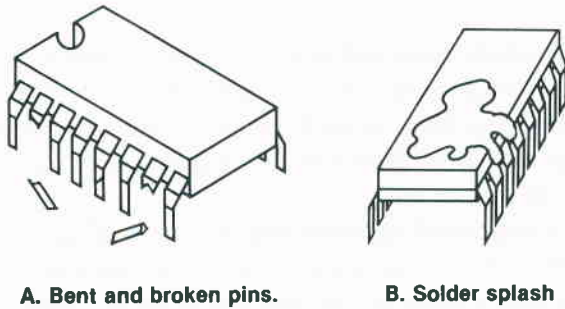
In general, CRT failures cannot be corrected by anyone other than a trained service technician. The voltages inside the chassis of your monitor reach as high as 25,000 volts. These levels can be lethal if you make a mistake.

The only adjustments you should attempt are those that can be accomplished from outside the chassis. If you see holes in the back of the chassis for alignment, you'd be better off keeping out of these, too; but if you feel experimental, be sure you use a plastic alignment tool (it looks like a thin pen with screwdriver-shaped ends).

## REPAIR-GENERATED FAILURES

Failures can be caused by overzealous or under-trained repair technicians. In the following list are some of the repair-generated "failures" that are possible:

1. *Devices "blown up" in handling.* This problem occurs when someone picks up ROM or CPU chips without first grounding any static electricity that he or she might be carrying.
2. *Bent or broken pins.* Watch the way you put those chips in. You can only straighten those pins so many times before they break off completely (Fig. 3-7A).
3. *Solder "splashes."* These are caused by dropping tiny balls of solder from the end of the soldering pencil right on top of the board, shorting out some of the circuit (Fig. 3-7B).
4. *Liquid "fry."* This occurs when someone holds or sets a liquid on top of or too close to the computer and then accidentally spills the liquid into the top of the keyboard while the computer is running. It's a real mess to clean up; lots of components will need replacing.



**Fig. 3-7.** Failures can be caused by overzealous or undertrained repair people.

5. *Component failure by asphyxiation.* This is caused by blocking the IBM PC vent openings or stuffing your computer with piggyback expansion boards that produce lots of heat without providing additional cooling. It “kills” components.
6. *The interface that doesn’t.* This can be caused by improper connection of cables. Plugging cables in one pin off blows chips. Also, if cable connectors are badly corroded, no signal can get through the cable.
7. *RFI wipeout.* Ribbon cables don’t have much protection from radio frequency interference (RFI) or magnetic fields produced around high-voltage machines or even power cords. Printers may print garbage, or nothing at all, if the ribbon cable connecting the computer to the printer runs alongside or through a loop in a power cord.

## HOW TO LOCALIZE FAILURES AND MAKE REPAIRS

O.K. You’re convinced that computer parts are pretty durable, but they can fail. How do we locate the failure?

There are three ways to localize failures, or find out which computer part is broken: (1) the hardware approach, (2) the software approach, and (3) the IBM-Easy approach.

### Hardware Approach

In the hardware approach, we use troubleshooting tools to measure voltage (logic) levels in the circuitry of the IBM PC. These tools include the logic probe, logic

pulsar, current probe, oscilloscope, multimeter, logic analyzer, and signature analyzer.

This approach requires some knowledge of electronics and test equipment. It is usually used as a last resort, so we’ll save the hardware approach for Chapter 6, “Advanced Troubleshooting.”

### Software Approach

The software approach is a troubleshooting method used widely by IBM PC repair technicians. As long as the disk drive will boot up properly, we can often find the failure by using diagnostic software. As you know, your PC has a built-in diagnostic software program that checks out the machine each time you apply power. This program is well written and does much to ease your mind that all is well inside.

#### Diagnostic Software

Watching strange things happen to your computer system can be frustrating. Often you can’t be sure immediately if you caused those weird characters on the screen or if your IBM PC just got sick. It’s better not to start taking the system apart for failure analysis if the machine isn’t really broken.

There is a way to determine that the system is healthy and that the errors are in the software program you’re trying to run. If the error is repeatable and the system drive still boots up, you can insert a diagnostic disk into your IBM PC system and run a series of programs that test the condition of the computer. These self-test routines can give you a 95 percent or greater confidence indicator that your PC is working properly and that you need to check your software.

Diagnostic programs can also indicate possible faults before they become hard problems. For example, some diagnostic software tells if the disk speed is too fast, too slow, or within a speed range where reading and writing data can occur without errors. These diagnostics measure the mechanical operation of your disk drives and are helpful in periodic preventive maintenance.

The effectiveness of self-test packages is measured by the level of confidence one can have that the component identified as bad by the software is indeed faulty. Some diagnostics are advertised as only 60 percent accurate; other companies say that their software test packages have an 85 percent confidence factor.

Most minicomputer diagnostics only identify faults to the board or module level. That’s because customers in the large companies that own most minicomputers usually depend on the computer manufacturer’s field

service representatives for repair. In this case, the diagnostic software is used as an improved user interface. The user can relay to the computer service center what the diagnostic tests have determined, reducing the time and cost involved in a troubleshooting and repair visit. This is exactly the situation with your IBM PC. If it fails during diagnostic testing, a number is printed on the screen. It is a key number to an IBM repair technician. The technician can use that number to identify the bad part. (As Chapter 4 will describe, you can also use this number to your advantage.)

Fortunately, most of the IBM PC microcomputer diagnostics can call out faults to the chip level (especially faults in memory). Besides the diagnostic software provided with the machine, several companies provide other diagnostic programs for the IBM PC. These programs test main memory, system ROM, the CPU, the monitor, the keyboard, the disk drive speed, and many peripherals.

The most common diagnostic programs check the system's RAM and some of the input/output components. Some routines check the operation of the CPU itself, but these usually locate only minor errors. It's difficult for a CPU like the 8088 to run a test on itself. Most diagnostics assume that the CPU is working properly.

Some memory diagnostics test to see if the computer is properly setting and clearing individual bits in memory and also if store or write operations are affecting more than one memory address location at one time.

### Common Memory Tests

The main memory tests find out whether test data can be correctly loaded into one and only one location in RAM. If a *storage error* occurs—that is, the data stored is not the same as the test data—a message is printed on your screen. If the correct data is stored, but into several different memory locations at the same time, an *addressing error* has occurred and this too is noted on your screen.

There are many algorithms (routines) for testing memory. Here is a list of the most common memory tests:

- Simple store and read
- Sequential numbers test
- Rotating-bit test
- Walking-bit test
- Dual-address test
- Butterfield test

- Sum test

A **simple store and read test** stores a known value in every location in a selected block of memory. Then it reads the contents of each location to ensure that the value was correctly stored. It is a quick and easy, but not too precise test.

A **sequential numbers test** involves storing all the binary number combinations for an 8-bit word sequentially into a block of 256 memory locations. Then the program starts at the first address location and reads out the data word stored, comparing it to the value that should be there. If the data is correct, the routine displays the words "all O.K." and the test moves on to the second location. If an error is found, the program displays an "error" symbol on the screen before the test starts over at the next address location. The test repeats until you reset your system.

A better memory test, the **rotating-bit test**, checks each address location to see if a binary bit stored in any one of the eight positions in a binary 8-bit data word will falsely set another bit in the same word. This test starts by loading the binary number 0000 0001 in the lowest RAM address. The contents of this address are then read back out and verified. If the 0000 0001 was correctly stored, the 1 bit is shifted one place to the left to 0000 0010 and the test is repeated. After the set bit (the 1) is shifted through all the binary combinations, stored in that same address location, read out, and verified, the entire test starts over at the next memory address location.

The **walking-bit test** improves on the rotating bit test somewhat. All 8 bits in a starting location are set to 0, or *cleared*. Then the first bit is set to 1 (0000 0001), as in the rotating-bit test. The program tests all 7 other bits to see if they have changed from 0 to 1. Then the second bit position is set to 1 and all other positions to 0 (0000 0010). Again all 7 other bit positions are tested. This process walks through each bit in that memory location, setting each bit to 1 and testing all 7 other positions.

Then the values are all reversed; all the cleared bits are set to 1 and the set bits are cleared to 0; and the entire process begins once more, but now as a rotating 0 test.

This test is quite time consuming. Apparently, it can take over 13 hours to check a 16K-byte area of RAM. And it can take over 52 hours to test 32K bytes of memory! You can just imagine how long it would take to test a fully packed IBM PC.

A **dual-address test** provides a thorough addressing check. Starting with the lowest memory address in a

selected block of memory, the program stores all 0's into the area (clears it to 0). It then stores all 1's (1111 1111) into the first location and checks all other locations to see if any other memory address falsely received any 1's. If all other locations are still "zero-loaded," the test location is cleared and the test shifts to the next higher address, storing all 1's in this location and then testing all other memory locations. This test repeats until the program reaches the end of the selected memory area.

A man named Jim Butterfield wrote a program that is a variation of the dual-address test. This test is in the public domain; that is, it is not copyright protected, and anyone is welcome to reproduce and use it. In the **Butterfield test** program, all 1's are stored in every location of the selected memory area. Then all 0's are stored in every third address location, starting with the first address. The algorithm then checks the contents of every memory address to make sure the values have been stored correctly.

Next, the program shifts the position of the "all 0's" word twice using the second and then the third locations in the memory as starting points. After the three-pass test using 0's in a memory field of all 1's, the bits are reversed and all 1's are stored in every third location of an all 0's memory field.

If an error is found, the program stops and the address of the error is displayed. If no error is detected, the program ends and the top address plus one is displayed on the monitor.

The **sum test** is probably the most sophisticated memory diagnostic test. It generates a unique data word to be stored in each location of memory to be checked. The data word is the sum of the two bytes that comprise that memory address. (Recall that it takes 16 bits to address 64K bytes of memory; 16 bits is two 8-bit bytes.) Since each succeeding address is one location higher, the value stored increases, and each value is unique to an address. A variation on this scheme can be used with the 20-bit address word in the PC. The algorithm then checks for correct value storage. If an error is found, the program displays the error and its location on the screen.

This diagnostic test is also time consuming. It's a good idea to run these kinds of dual-address tests on small blocks of memory rather than testing all of the RAM. It has been determined that the testing time quadruples for each doubling of the amount of memory tested.

### Self-diagnosis

There is a trend toward building diagnostic

capability into peripheral equipment such as printers and plotters. There is also a strong incentive to place diagnostics in CRT displays and disk drives, because so many of these devices are being sold.

Disk drives and printers function both electronically and mechanically. The electronic controller portions of these machines can contain their own diagnostics and, indeed, many controllers now do some form of self-diagnosis each time the system is powered up. These tests check for faults in the electronics.

Mechanical components are inherently less reliable than electronic ones, so peripherals containing mechanical parts have diagnostics that regularly check their internal operation. Most of the conditions monitored are operator related; for example, "paper out" or "ribbon out." Disk drive diagnostics measure mechanical parameters such as speed and head alignment. We'll cover disk speed adjustments and head alignment in Chapter 5, "Routine Preventive Maintenance."

All of the "canned" diagnostic packages use some version of the seven test algorithms previously described. Each diagnostic program is a valuable addition to your "troubleshooting toolbox," but no software diagnostic can help if your system won't boot or display.

### The IBM-Easy Approach

Usually, when a chip comes to the end of its useful life, a catastrophic failure occurs—it cooks itself internally. While your eye can't always see the defect, you can find the problem without much effort. In most cases, the use of the "Troubleshooting Index" in Chapter 4 will enable you to locate and correct the trouble quickly; but for those problems that are not as easy to identify, let's refer again to our guidelines for success.

1. **Don't panic.** You now have a troubleshooting guide that will help.
2. **Observe the conditions.** What conditions existed at the time of failure? What actions were in progress? What program was running? What was on the display screen? Was there an error message?
3. **Use your senses.** Is there any odor present from overheated components? Does any part of the system feel overly hot?
4. **Retry.** If the display is dark, check the brightness control, the power plug, and the power cord. Is the plug snug in the back of the computer? Is the other end of the power cord

plugged into a wall socket? Is the wall socket working? If any of these isn't right, correct the problem and try again.

If your problem involves an external display, the printer, or other I/O peripheral equipment connected to your IBM PC by cable, make sure the power to the system is off, disconnect the power plug from the computer, and then reseal all the connector cables associated with the failure. Cables have a habit of working loose if they aren't clamped down. Once you've checked the cable connections, reconnect the power plug, power up, and retry.

If a disk didn't boot (was not read in and acted on by the disk drive), try booting the disk in the other drive or try booting another copy of the program disk. You could also try booting the disk in another IBM PC computer. It's a good idea to always use a copy of the program disk rather than the original. That way any failure of a disk drive won't cause as much frustration if it destroys data on the disk as it would if the disk were the program master. If data is altered by a malfunctioning drive, the disk can be recopied again from the program master once the drive problem is resolved.

If the system still won't work, disconnect all the external equipment connected to the computer, and try to operate the system unit alone. Sometimes, failure in a peripheral device shows up as trouble in another part of the computer. If the computer works by itself, the problem is probably in an external device or in the connecting interface.

5. **Document.** Document all that you see and sense. Write down all the conditions that you observed at the time of failure. Write down what conditions exist now that failure has occurred:
  - What is your PC doing?
  - What is it not doing?
  - What is being displayed?
  - Is there an error message?
  - What is still operating?
  - Is power still indicated on each part of the system?
6. **Assume one problem.** In digital circuitry, the likelihood of multiple simultaneous failures is

low. Usually, a single chip malfunctions, causing one or more symptoms.

7. **Diagnose to a section.** If the system worked when the peripherals were disconnected, turn the power off and reconnect one of the peripherals. Power up and test. If the unit still works, turn the power off and reconnect another peripheral. Power up and test. Follow this procedure until the unit fails. The built-in diagnostic tests are a big help here. Once failure occurs, you know what device or what interface section has the problem.

If you disconnect all the peripherals and test the computer alone and it still won't work, try to determine what section or division of the machine failed. Describe the failure in simple terms—drive B won't read a disk, for example.

8. **Consult the symptom index.** Chapter 4 includes an index of the troubles most commonly encountered with the IBM PC. It includes a section on system error displays. If any error codes are displayed, these self-diagnostic results can guide you to locate the problem. If the symptoms that you see match a problem described in the "Troubleshooting Index," turn to the referenced page and follow the instructions under "Troubleshooting Procedure."

**Caution:** Any time you open the computer, ensure that the power is off and touch a metal lamp or other grounded object to remove any static electricity your body may be carrying.

9. **Localize to a stage.** Turn off the power to the computer and disconnect the power plug. Disassemble the computer as shown in the Appendix. Follow the troubleshooting steps and procedures in Chapter 4, "Specific Troubleshooting & Repair for the IBM PC," to localize the failed stage.
10. **Isolate to a failed part.** Closely following the procedures in Chapter 4 should guide you to the failed part. Here are some hints for determining why a part is failing.
 

*Loose chips.* Chips have a tendency to work themselves out of their sockets under normal operation. A loose chip could be the cause of your whole problem. "Loose chips sink MIPS" (MIPS stands for millions of instructions per second—a measure of computer capability).

*Noise.* Sometimes a problem is caused by noise. Not audible noise, but electrical noise, the kind that produces “static” on your radio. Noise in the computer system can cause data to be lost or incorrect data to be stored or displayed. Noise will be discussed in greater detail in Chapter 5.

**Note:** To avoid noise problems, keep cables clear and away from power cords, especially coiled power cords.

*Intermittent failures.* Sooner or later you’re going to be confronted with those once-in-a-while failures called *intermittents*. These can be really frustrating. Unlike a hard (constant) failure, an intermittent problem shows up randomly, or only at certain times (usually when you expect it least). Intermittent failures are difficult to handle using standard troubleshooting methods.

Since intermittent failures can be caused by shock, vibration, or temperature change, these conditions can be used to find and sometimes even correct them. Here are some helpful hints regarding intermittent failures:

**Caution:** The following steps are conducted with the computer open and operating. Be careful not to short out any connectors or pin leads.

Use only a nonmetallic or wooden object to probe components inside an energized IBM computer.

- a. Check, clean, and reseat all connector boards and cable plugs.
- b. Tap gently at specific components on the suspected board using a nonmetallic rod or screwdriver.
- c. Heat the suspected area with an infrared lamp or hair dryer. Don’t overheat it.
- d. Spray canned coolant on a suspected component. A component that fails intermittently can sometimes be found with this technique used by service technicians. Several companies sell pressurized cans of coolant spray that have long plastic extender nozzles for pinpoint application on top of a suspected chip. By cooling the device with the computer energized and operating the system, you can identify chips on the verge of total failure. The system works for a few moments

until the chip heats up again and starts causing problems again.

- e. After you’ve found the area where the problem is located, make sure the power is off, and use a strong light and a magnifying glass to look for small cracks in the wiring or solder connections.
- f. The final method for fault isolation to a component is signal tracing. This technique will be covered in Chapter 6, “Advanced Troubleshooting.”

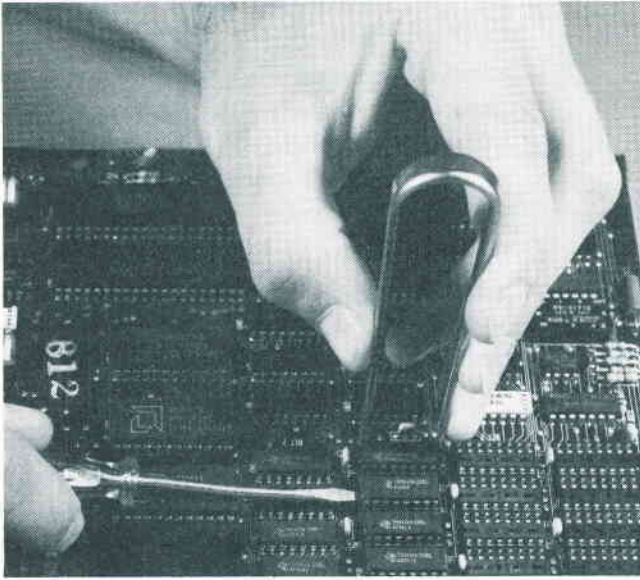
A large section of Chapter 6 is devoted to identifying and solving the intermittent problem. For now, let’s say that good cleaning, careful pin and board reseating, and inside-the-case temperature control will prevent the occurrence of most random failures. Board reseating need not be a problem on the PC since the boards can be secured with screws.

11. **Repair.** A disassembly and reassembly guide is located in the Appendix. If the problem is a marginal or blown chip, you can replace it but be sure your replacement chip is of the same logic family as the original (i.e., replace 74LS74 with another 74LS74).

*Removing socketed chips.* It takes a little practice before you can remove a socketed chip without it jumping out, flipping in mid-air and sticking you right in the thumb or index finger with that double row of tooth-like pins. Fortunately there are two devices that make the job much easier. These are the tiny screwdriver, or “tweaker,” and the IC extractor tool. Fig. 3-8 shows how each tool can aid in removing stubborn chips from their sockets.

The extractor tool was designed to make chip removal easier, and its use is recommended. Slip the tweaker under the chip to start it out of the socket and then use the chip extractor to complete the removal. This prevents the tweaker from slipping or the extractor tool from inadvertently hooking onto the socket for the chip and pulling the socket up out of its solder connections along with the chip.

*Replacing socketed chips.* Getting the chip out is only part of the repair challenge. Replacement of chips that are in sockets may look easy, but there are some pitfalls you should be aware of. Those fragile pins on your



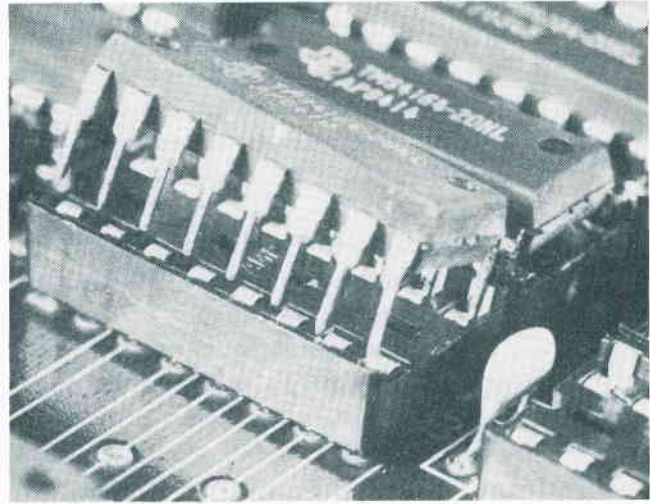
**Fig. 3-8.** ICs can be removed with a chip extractor or by gently prying up with a tiny screwdriver (tweaker).

chips bend easily, and it doesn't take very many straightening actions to break a pin completely off. Here's how to do it:

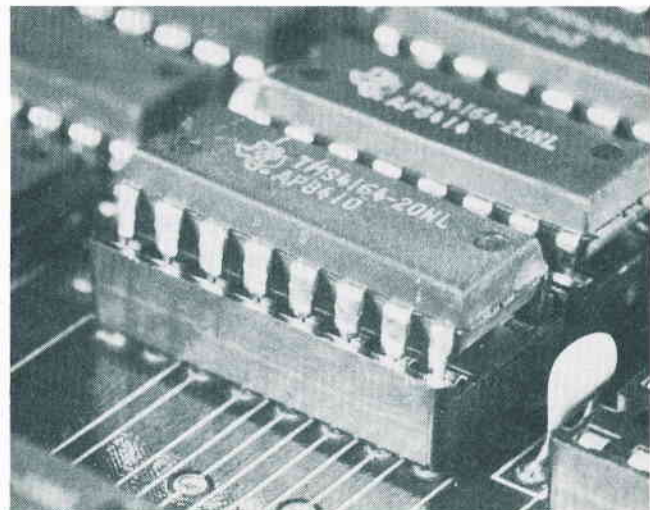
- a. Line up the pin-1 end (with the notch or dot) with pin 1 on the socket. (Notice how all the other chips around this socket are mounted.)
- b. Place the chip over the socket, lining up one row of pins with its socket holes as shown in Fig. 3-9.
- c. With the chip at a slight angle, press down gently, causing the row of pins in contact with the socket to bend slightly, which lets the other row of pins slip easily into their sockets, as shown in Fig. 3-10.
- d. Press the top of the chip down firmly to seat the chip completely into the socket. Be careful not to flex the board too much. If necessary, support the motherboard with the fingers of your other hand as you press the chip into place.

It is pretty easy to make mistakes in chip replacement. Here are some more things to be careful of:

- Make sure you don't put the chip in backwards. The notch or dot marking the pin-1



**Fig. 3-9.** Place the chip over the socket as shown.

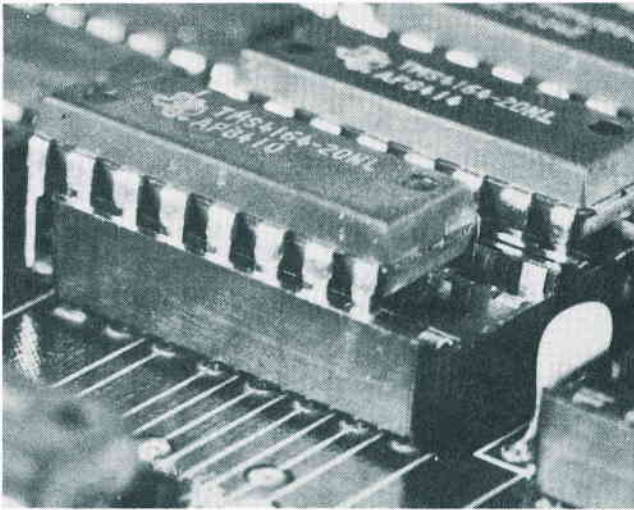


**Fig. 3-10.** Once each row of pins has been started into the socket, press down gently to complete the chip insertion.

end of the chip is intended to help you correctly line up pin 1 on the chip with pin 1 on the socket.

- Don't offset the chip over the socket by one pin as shown in Fig. 3-11.
- Don't force the chip down so one of the pins actually hangs out over the edge of the socket or is bent up under the chip.

*Soldered chips.* Removing and reinstalling chips that are soldered into the motherboard are difficult actions and require more than a passing knowledge of soldering techniques.



**Fig. 3-11.** Be careful not to offset the chip by one pin.

Only attempt this part of the test-repair procedure if you have experience soldering and desoldering multilevel printed-circuit boards. Otherwise, bite the bullet, and take your machine to someone who has the knowledge, experience, and equipment to successfully make this type of repair.

If a chip to be replaced is soldered into the motherboard, whether you do it yourself or have a repair technician do it, always replace the chip with a socket. Solder the socket in, and then plug the new chip into the socket. This will make it much easier to replace this chip next time.

*Checking.* After each repair action, test the system for correct operation. In some cases, substitution of a good chip corrects the problem. After each substitution, reassemble the system enough to power up and test the repair. This process is very likely to locate the trouble.

12. **Test and verify.** This is an important step. We need to know that all is now well with the system. After booting up and testing using a copy of your DOS program disk, run the same program that was in the machine at the time of failure.

**Note:** It's a good idea to log the repair action in a record book to develop a history of the maintenance conducted on the machine. Record sheets are included at the back of this book.

## Obtaining Replacement Parts

Finding that a trouble really exists is only part of the problem. You must locate the specific chip (if the software doesn't) and then make the repair. This too, can be somewhat challenging. Fortunately, most of the chips on your IBM PC system board are standard 74xx chips and are readily available. Your local Radio Shack store carries most of the 7400-series chips. In fact, just about any electronic parts store will have a supply of 7400-series chips. Most of the 8xxx series chips are also easy to obtain. You can make a list of the spare parts you'd like to have on hand from the listing in the Appendix.

The custom IBM PC chips—the five ROMs—are proprietary to IBM, and I recommend you buy all of these custom chips directly from IBM or from your local IBM PC repair center.

Should you be using an 8087 coprocessor in your PC, and need to replace the 8087 or the 8088, be aware that these are often sold as a matched pair. To see whether your 8088 will work properly with your 8087, check the copyright date marking on the top of the chip. If the copyright date is "78," it may work with the 8087. If the date is "'78'81," it is certain to work with the coprocessor chip. Any other date stamp might not work, unless it is stamped "P8088" or "D8088" followed by "54716." Chips with these markings are revisions of earlier 8088 devices and will also work.

The trade magazines sometimes advertise inexpensive packages of IBM PC repair parts. Some of the PC chips can be replaced only by a board swap-out, or board exchange. The exchange price may seem high, but you do get a new board, and the kind of failure that necessitates this action does not occur very often, so this kind of expense is required very infrequently.

## If It Still Doesn't Work

If the IBM-Easy troubleshooting steps don't solve the problem, you have two choices: either take the machine to a service repair center or break out (or borrow) some test equipment, open the schematics, and start hunting for the failed or malfunctioning stage. Try signal tracing with a logic probe and a logic clip. Use an oscilloscope and a digital voltmeter (DVM) to test the discrete components such as transistors, capacitors, and resistors. Connect a logic analyzer or signature analyzer to the system and step through the circuitry. Make voltage and resistance tests to locate the bad

part. Test hardware and advanced troubleshooting methods are discussed in greater detail in Chapter 6.

## IF YOU MUST USE A SERVICE CENTER

Before you disassemble your system and take it down to the repair shop (if that's your alternative), there are some things that you can do to minimize your expense. The following Repair Service Checklist is a guide to be used before, during, and after the service center repair. Each step is expanded here for clarity.

1. **What is affected?** Find out if the problem is "catastrophic" and affects the operation of everything. If it affects only a part of the system (such as a disk drive) you may be able to take the drive only in for service center repair.
2. **Is the problem in software?** Be certain it isn't. Try to run a program that you know is good.
3. **Was the problem caused by operator error?** Try a different operation that uses the same hardware or function.
4. **Is it an intermittent failure?** If your problem is intermittent and you take it in for repair, it could take quite a while (at quite a fee) for the problem to occur and be found and fixed. You may just want to live with the problem until the intermittent becomes permanent (a hard failure). At least then you will have something concrete to troubleshoot.
5. **Describe the problem in writing.**
  - What was the system doing at the time of failure?
  - What were you doing at the time of failure?
  - What is the system doing now?
  - What isn't it doing now?
  - Is there an error code?

Provide a copy of the written description to the service technician.

6. **Ask for recommendations.** Your local users group can probably provide the names of some good, reasonable service centers.
7. **Log the serial numbers of all system components you'll be turning over for repair.**
8. **Request an estimate of time and charges.**

9. **Request a repair listing.** Ask to have a detailed listing of what was repaired or replaced, including a break-out of charges.
10. **Check on warranties.** The repair may be covered by a current warranty. In any case, make sure the work and parts are warranted for at least 90 days.
11. **Test before acceptance.** Test run the system before taking it out of the shop.

## SAFETY PRECAUTIONS DURING TROUBLESHOOTING AND REPAIR

As you do with all devices that use or operate on electrical power, you must observe certain precautions to prevent damage to yourself or your IBM PC system:

1. **Keep out of the display monitor chassis.** The voltages inside your monitor or television are dangerous, and only trained technicians should ever troubleshoot and repair a display unit. Voltages can be as high as 25,000 volts, so stay out!
2. **Don't troubleshoot your IBM PC power supply.** The circuits in the power supply convert the 115-volt line power in your home or office to the 5–12 volts used by the motherboard. That 115-volt electricity can be harmful! Apparently IBM feels the same way; they use some special screws to secure the metal shield over the power supply. This guide does not discuss power supply troubleshooting and repair.
3. **Always turn the power off, ground yourself, and pull the plug.** Touch a grounded metal object such as a desk lamp, and then pull out the power cord before touching anything inside. Many failures are caused by people who don't follow this rule.
4. **Handle diskettes carefully.** Don't write on a label once it is attached to the disk jacket. Don't lay disks on a dusty, dirty surface. Keep cigarette ash away from your disks and your computer system. Don't touch the disk surface. Don't try to see how flexible a floppy disk is. Don't set your disks on, or in front of, a TV or color monitor.
5. **Don't cycle the power on and off quickly.** Wait 7 to 10 seconds to let the capacitors in the power supply discharge fully and to allow the

circuits to return to a stable (quiescent) condition.

6. **Use a power strip to apply power to all components** (except a hard-disk drive). This saves wear and tear on the PC's ON/OFF switch. Most power strips also have a built-in overload protection for voltage spikes. Voltage spikes can harm your computer system. (Don't connect a hard-disk drive to the same power strip if it must be energized and up to speed before the computer is turned on.)
7. **Keep liquids away from the computer.** If you ever spill a soda on the keyboard, you'll be amazed at how sticky soda becomes after frying components all over the inside of the keyboard.
8. **Handle components with care.** Don't let chips lie around—the pins can get bent or the integrated circuits can be ruined by static electricity.

Some logic devices require extra care when you touch or handle them. With TTL (74xx series) chips you have no problem removing or inserting these devices. But the metal oxide semiconductor (MOS) chip family (MOS, CMOS, NMOS, etc.) needs some extra care since these chips are more susceptible to static electricity than TTL chips are.

The MOS chips in your IBM PC are:

- The 8088 CPU
- The ROM chips
- The 8237 DMA controller chip

- The 8253 PIT chip
- The 8255 PPI chip
- The 8259 PIC chip
- The 8284 clock generator chip
- The 8288 bus controller chip

Don't be afraid to touch the chips in your computer. Most guides for handling MOS chips lean far toward the supersafe zone and sometimes cause more problems than they prevent. These chips can be damaged by the static charge built up by scuffing your feet across a carpet; so be sure to ground yourself by touching a metal lamp or grounded object before you reach for a chip inside the IBM PC chassis. In addition, conductive foam provides static charge protection during storing or transporting of MOS-type chips.

Additional precautions should be observed when you use test equipment with your IBM computer. These will be covered in Chapter 6, "Advanced Troubleshooting Techniques."

## SUMMARY

So there you have it. In this introductory chapter on troubleshooting, you've learned the troubleshooting steps to success; how to recognize the components inside the IBM PC; how components, disks, and displays fail; and various methods for finding failures in your computer system.



# Specific Troubleshooting & Repair for the IBM PC

---

**C**hapter 4 is an IBM PC-specific troubleshooting and repair guide focusing on a large variety of computer failures. The section is divided into five parts as follows:

1. Start-up problems
2. Run problems
3. Display problems
4. Keyboard problems
5. Other I/O problems

Each fault can be associated with one of these areas. By letting your "fingers do the walking" through the Troubleshooting Index, you can quickly locate the page where your particular problem is addressed.

Part 1 covers all symptoms that can occur at the time you turn the power on, or at start-up, including no power available, no boot up of the disk, and system error problems. The PC comes with a built-in diagnostic test program, and most users also receive a diagnostic disk to use in conjunction with the built-in diagnostics. Therefore, it's possible to get a system error number printed on your screen if your system experiences a malfunction during start-up.

Part 1 lists the meanings of most system error codes. This listing includes system error numbers that

identify the specific RAM chip that has failed. If no system error is displayed, or if a system error cannot be displayed, the remainder of Part 1 and the following sections will provide guidance in locating the trouble.

Part 2 discusses all symptoms that can occur after initial boot up, such as faulty disk read or write, bad memory, and program lock-up.

Part 3 addresses difficulties associated with the display portion of the computer; for example, no display, no text mode, no hi-res or no lo-res, video synchronization failures, character faults, bad graphics, and others.

Keyboard problems are detailed in Part 4. This section covers such faults as bad key operation.

Part 5 encompasses all the other input and output problems, including speaker faults, cassette I/O failures, and light pen malfunctions.

Each part is subdivided into specific failures and provides symptom, problem, possible cause, and repair action. This data is followed with step-by-step troubleshooting instructions illustrated with applicable schematic drawings and a chip location layout diagram to make replacement easy.

If any step seems too complex, stop where you are and seek help from a service center technician. You should be able to find and correct most problems, but occasionally a component such as a resistor, capacitor,

or diode fails. Finding these failures requires advanced troubleshooting techniques, and this book does not assume you have these skills. If you'd like to try the advanced methods, refer to Chapter 6 for guidance. Always observe good troubleshooting procedures.

**Note:** The following troubleshooting techniques may require soldering, if you are uncomfortable with this, go as far as you can without soldering and then consult your local IBM Service Center.

**Note:** Desoldering or soldering on the IBM PC motherboard may void your warranty.

## TROUBLESHOOTING INDEX

- 1. Start-up problems
  - System errors during start-up . . . . . 76
  - System won't boot . . . . . 78
    - No power light, nothing works, nothing on screen . . . . . 78
    - Power light on, nothing works, nothing on screen . . . . . 79
    - Power light on, drive won't boot a disk . . . . . 81
- 2. Run problems
  - One drive won't read . . . . . 81
  - Neither drive will read . . . . . 84
  - One drive won't write (read functions properly) . . . . . 87
  - Neither drive will write (read functions properly) . . . . . 89
  - Drives can't be accessed . . . . . 91
  - Computer locks up, keyboard entries won't work . . . . . 93
- 3. Display problems
  - Monochrome monitor and adapter card . . . . . 95
    - No display . . . . . 95
    - No vertical synchronization (sync) . . . . . 98
    - No horizontal synchronization (sync) . . . . . 100
    - Bad characters displayed . . . . . 101
    - No lo-res display or no hi-res display . . . . . 104
  - Color/graphics monitor and adapter card . . . . . 106
    - No display . . . . . 106
    - No vertical synchronization (sync) . . . . . 110

- No horizontal synchronization (sync) . . . . . 112
    - No text, but graphics works . . . . . 113
    - Bad characters displayed . . . . . 114
    - Bad or no color . . . . . 118
    - No hi-res text, no lo-res text, or no graphics . . . . . 120
  - 4. Keyboard problems
    - Keyboard won't respond at all or prints wrong character . . . . . 121
    - One or more keys won't work . . . . . 124
    - Keyboard stays in upper or lower case . . . . . 124
  - 5. Other I/O problems
    - Speaker won't work properly . . . . . 125
    - Light pen won't work properly . . . . . 128
    - Cassette won't load data . . . . . 130
    - Can't write data to cassette . . . . . 132

## START-UP PROBLEMS

### SYMPTOM: System errors during start-up

Four types of error indicators may appear during the initialization, or start-up process:

- Beep indicators from the built-in speaker
- System error codes
- I/O error codes
- Other error displays

The following listings will assist you in isolating the module, subunit, or peripheral that has failed.

### Beep Indicators

Indicator	Failure location
No beep, nothing happens	Power, power supply
Continuous beep	Power, power supply
Repeating short beep	System board
1 long, 1 short beep	System board
1 long, 2 short beeps	Display circuit
1 short beep, blank or incorrect display	Display
1 short beep, Cassette BASIC display, no disk boot	Diskette, disk drive

### System Error Codes

These error codes can appear alone or in conjunction with other numbers.

Code	Problem
100	Option configuration wrong
199 100	Software option configuration installation wrong. Check switches.
101	System board malfunction
131	Cassette port error
201	RAM failure
xxxx = 201	Memory failure (see Fig. 4-1)
1055 = 201	DIP switches set wrong
2055 = 201	DIP switches set wrong
xxxx = 201	RAM chip malfunction (see Fig. 4-2)
PARITY CHECK x	
301	Keyboard malfunction, keyboard cable disconnected
xx301	Keyboard circuitry malfunction (xx is a hexadecimal value representing the scan code of the malfunctioning key)
401	Monochrome adapter card malfunction
501	Color/graphics adapter card malfunction
601	Diskette or disk drive interface malfunction (drive adapter, cable, drive A)
606	Drive assembly or drive adapter malfunction
607	Disk is write protected; disk not inserted right; write-protect switch bad; analog card malfunction
608	Diskette is bad
611	Drive data cable or disk drive adapter card is bad
612	Drive data cable or disk drive adapter card is bad
613	Drive data cable or disk drive adapter card is bad
621-626	Drive assembly is bad

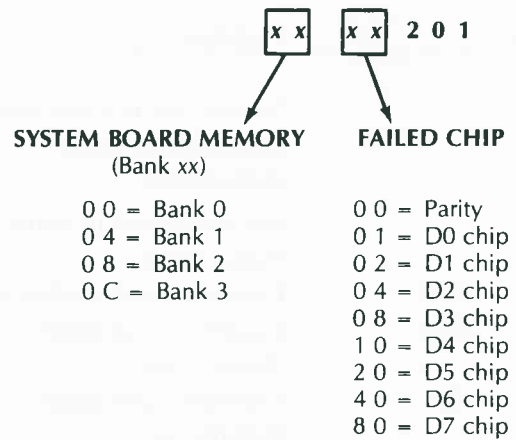


Fig. 4-1. Memory failure error codes.

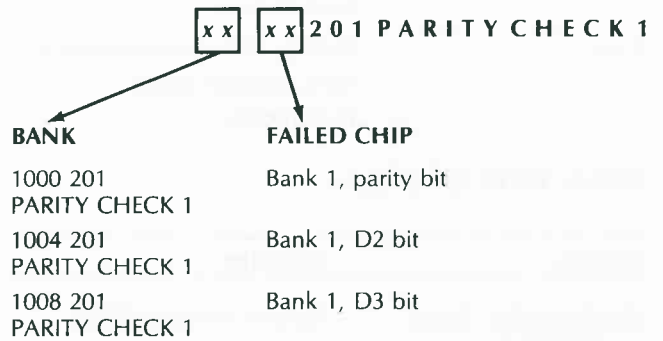


Fig. 4-2. Some examples of parity check RAM chip malfunctions.

### I/O Error Codes

Code	Problem
199	Printer adapter card or printer malfunction
432	Printer adapter card or printer malfunction
7xx	System unit I/O malfunction
9xx	System unit I/O (parallel printer adapter) malfunction
901	Printer adapter card or printer itself is bad
11xx	System unit malfunction
12xx	System unit malfunction
13xx	Game control adapter card malfunction
14xx	Printer interface malfunction

Code	Problem
15xx	System unit or communications adapter cable malfunction
18xx	Expansion unit or cable malfunction
1819	Expansion unit malfunction
1820	Expansion unit cable malfunction
1821	Expansion unit cable malfunction
20xx	System unit or communications adapter cable malfunction
21xx	System unit or communications adapter cable malfunction

**Other Error Displays**

Display	Meaning
Blank display, beep, drive starts to boot, but no Cassette BASIC message on screen	System Monitor BIOS ROM (U33) 8284 clock generator bad
F600 ROM	Cassette BASIC ROM (U29) problem
F800 ROM	Cassette BASIC ROM (U30) problem
FA00 ROM	Cassette BASIC ROM (U31) problem
FC00 ROM	Cassette BASIC ROM (U32) problem
KEYBOARD NOT FUNCTIONAL	Keyboard problem
PARITY CHECK 1	Power supply problem
PARITY ERROR 1	Try reseating RAM chips
PRINTER PROBLEMS	Printer problem, check interface

**SYMPTOM: System won't boot**

If booting won't work, the IBM PC DOS manual suggests you reread the manual. You can probably deduce the problem faster by noting the condition of

the machine at time of "failure" and following the logical troubleshooting steps outlined in this chapter.

A number of things can cause the computer to boot improperly or not to boot at all: wrong diskette in the drive, no operating system on the diskette, cables loose, adapter card not fully seated, disk drive failure, memory chip bad, no clock pulses, or even a forgotten unplugged power cord.

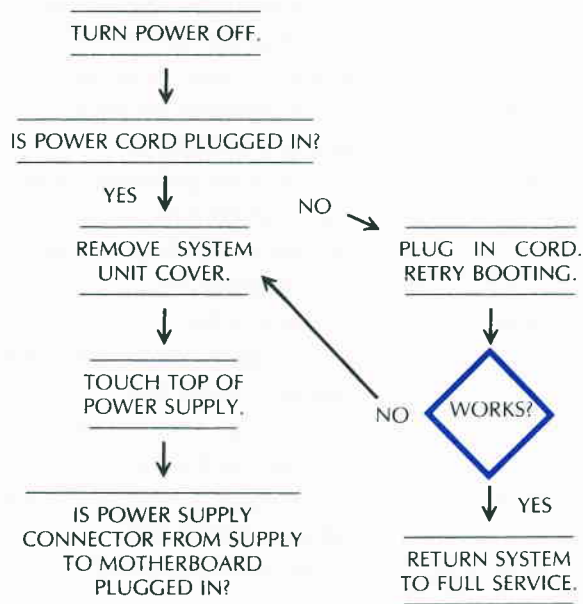
To find the problem, select the subcategory that best describes the symptoms and turn to the appropriate page for a step-by-step troubleshooting guide:

Subcategory	Page
No power light, nothing works, nothing on screen . . . . .	78
Power light on, nothing works, nothing on screen . . . . .	79
Power light on, drive won't boot a disk . . . . .	81

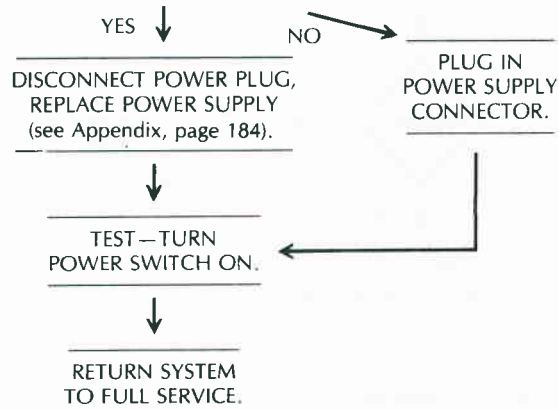
**SYMPTOM: Won't boot, no power light, nothing works, nothing on screen**

Problem	Possible cause	Repair action
No power	Power cord not plugged in	Plug in cord.
	Power supply faulty	Replace.
	Power cable not connected	Plug in cable.

**Troubleshooting Procedure**



(Continued)



To locate the power supply, power cord, and power supply connector, refer to Fig. 1-4, which shows the inside of the IBM PC system unit.

**Circuitry Affected**

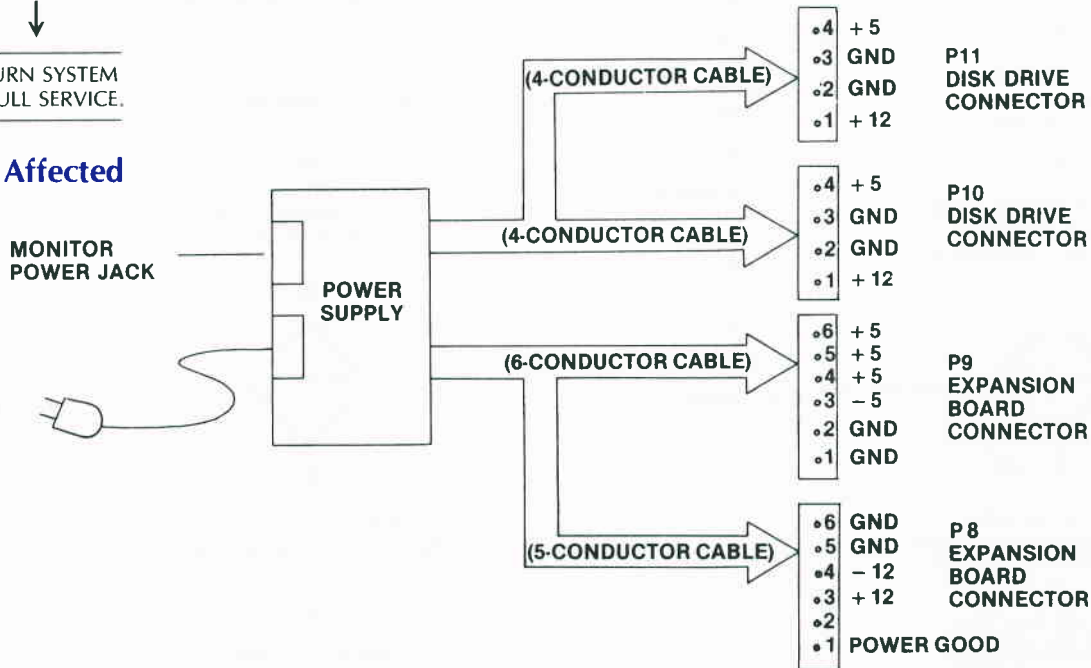
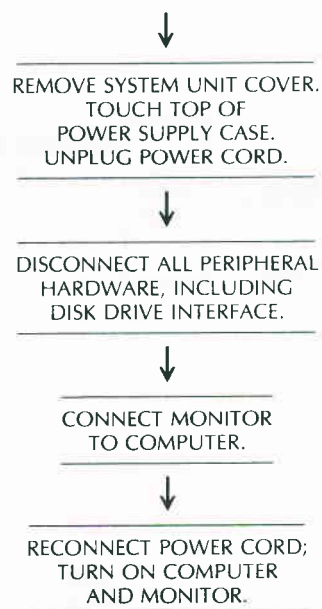
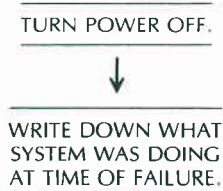


Fig. 4-3. Simplified power supply circuitry.

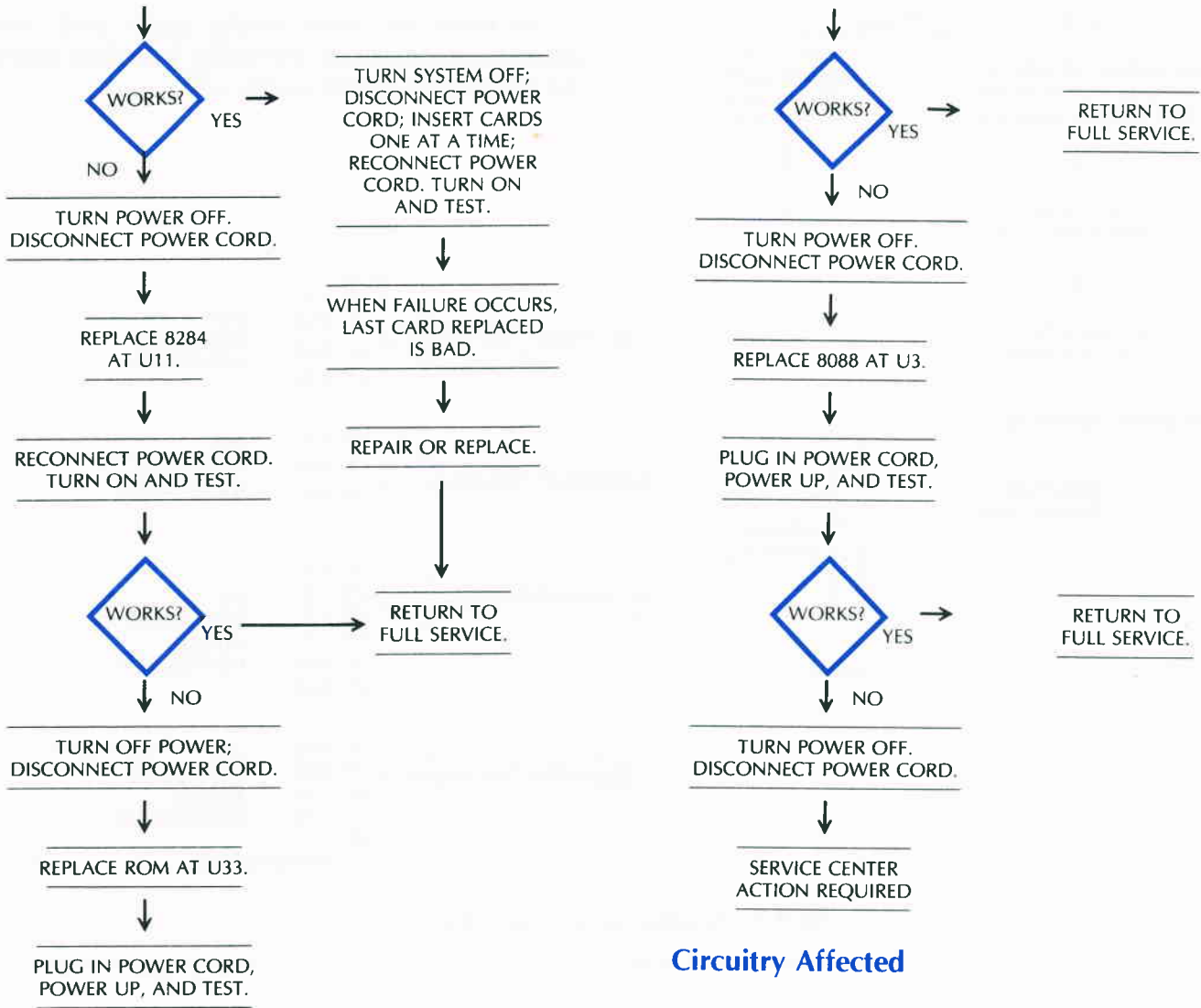
**SYMPTOM: Won't boot, power light on, nothing works, nothing on screen**

Problem	Possible cause	Repair action
No clock	8284 at U11 bad 8088 at U3 bad Bad crystal	Replace and test. Replace and test. Replace and test.
No start-up data	Bad ROM at U33	Replace and test.

**Troubleshooting Procedure**



(Continued)



**Circuitry Affected**

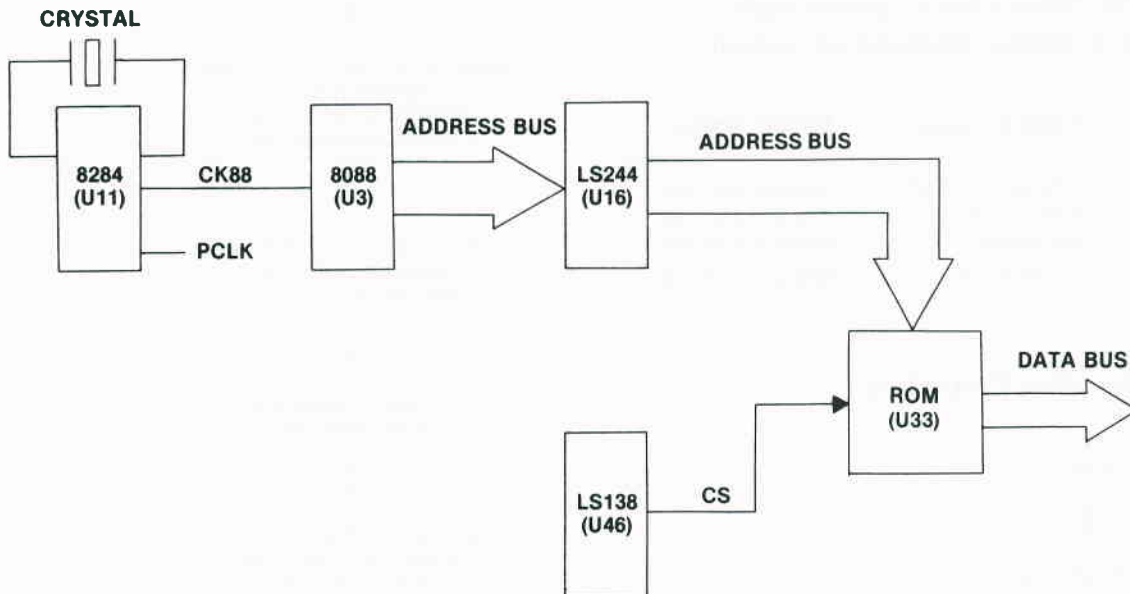


Fig. 4-4. Clock circuitry.

Chip designation	Description	Location
8284	Clock generator	U11
8088	Microprocessor	U3
Monitor ROM	8K x 8-bit static ROM	U33

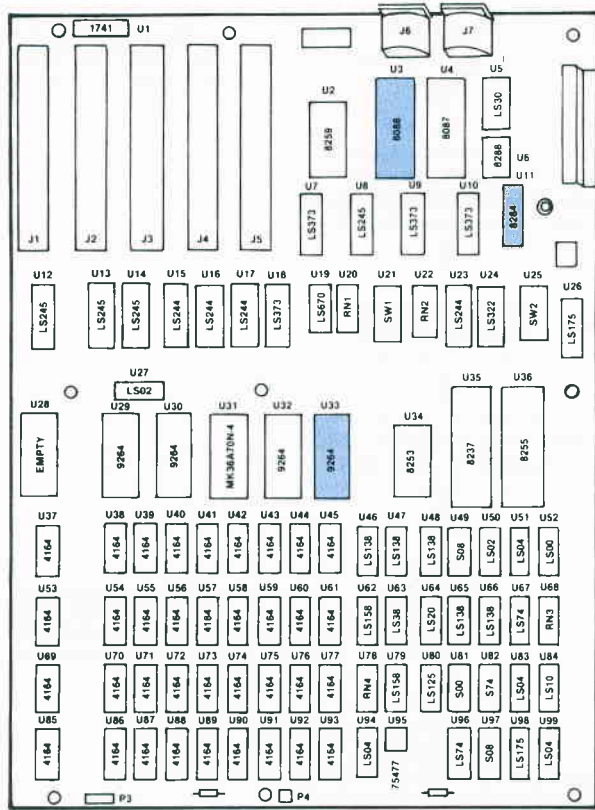


Fig. 4-5. Chip location guide. This represents the IBM PC system board and is a guide to help you locate the chips of interest.

**SYMPTOM: Power light on, drive won't boot a disk**

(See "One drive won't read" or "Neither drive will read" section.)

**RUN PROBLEMS**

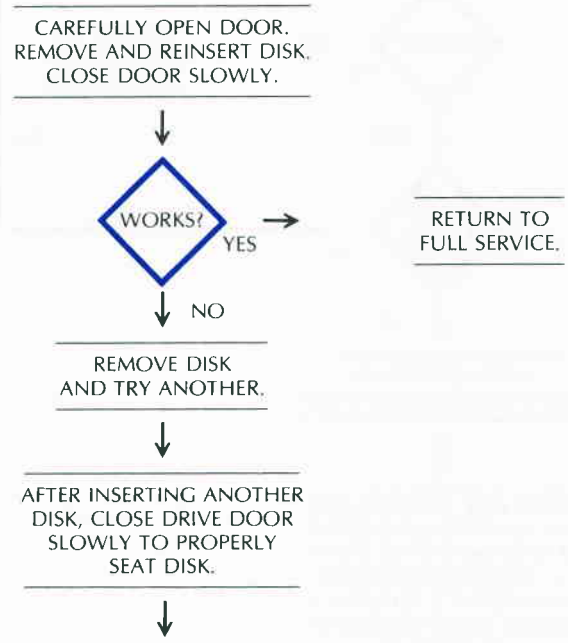
Symptom Category:	Page
One drive won't read . . . . .	81
Neither drive will read . . . . .	84
One drive won't write (read functions properly) . .	87
Neither drive will write (read functions properly) . .	89
Drives can't be accessed . . . . .	91
Computer locks up, keyboard entries won't work .	93

This section covers those problems you might encounter while your system is running. For example, you might attempt to do something and get a response entirely different from what you expected.

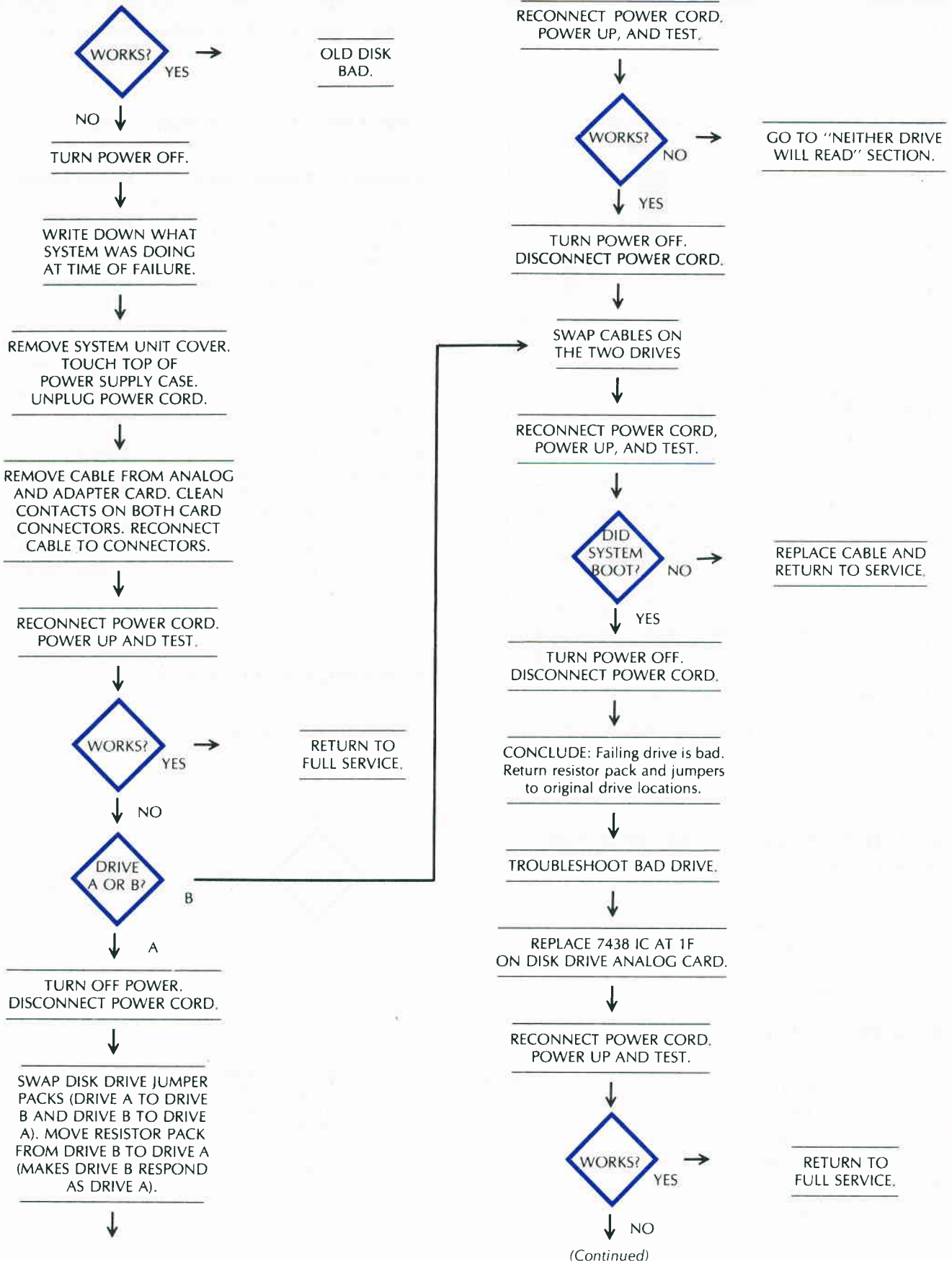
**SYMPTOM: One drive won't read**

Problem	Possible cause	Repair action
Data not coming from disk	Bad disk Bad data on disk Disk not seated properly	Replace disk. Try another disk. Reseat disk.
Read head not reading	Bad read head	Ask service center to replace head.
Data not coming out of drive	Cable bad or loose	Reseat or replace.
Bad IC on analog card	Bad 74S38 at 1F Bad 221 at 5E Bad 74LS86 at 5D Bad 74LS74 at 5C Bad 311 at 5B Bad 592 at 4A Bad 733 at 3A	Replace and test. Replace and test. Replace and test. Replace and test. Replace and test. Replace and test.

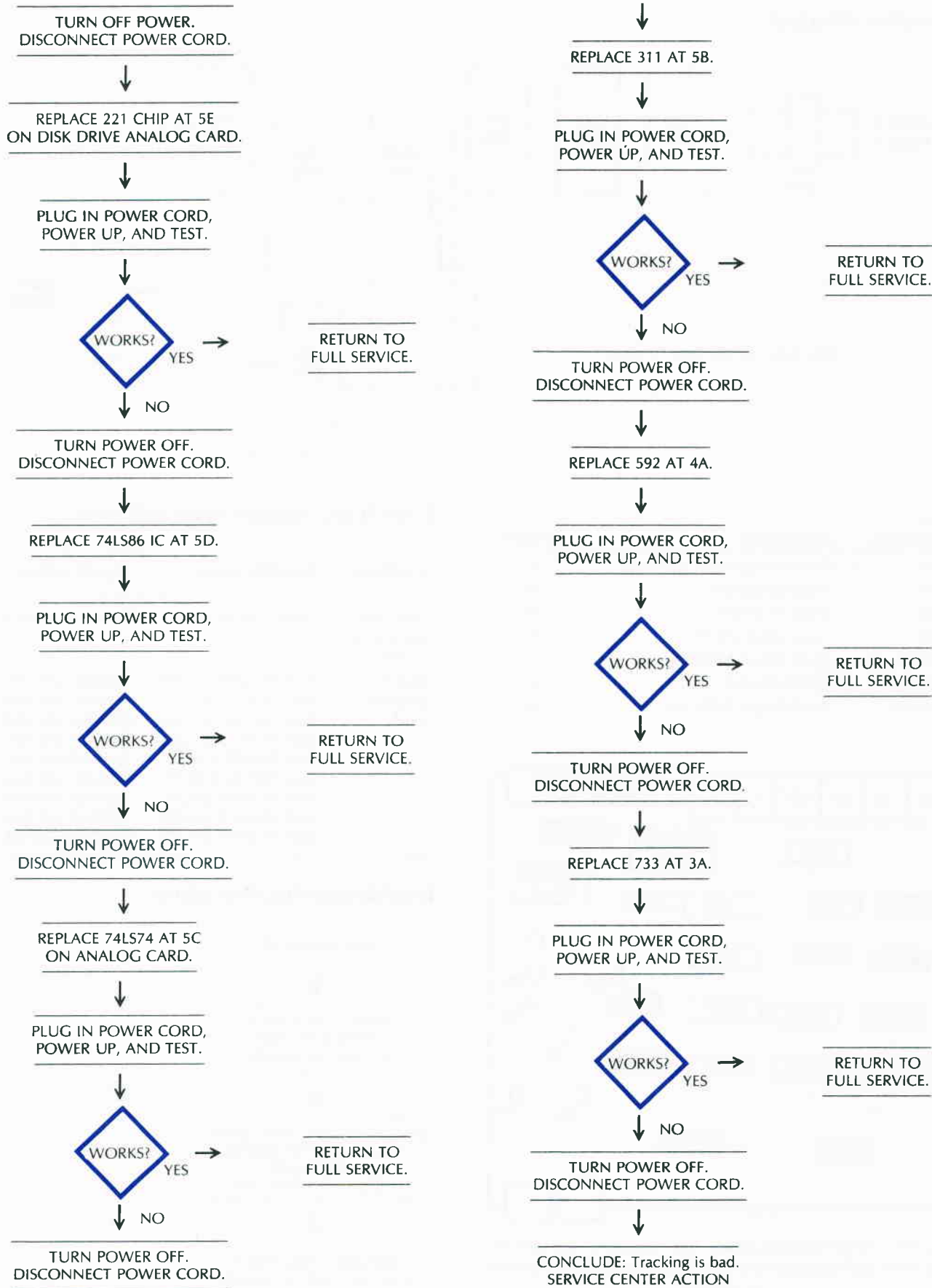
**Troubleshooting Procedure**



(Continued)



(Continued)



### Circuitry Affected

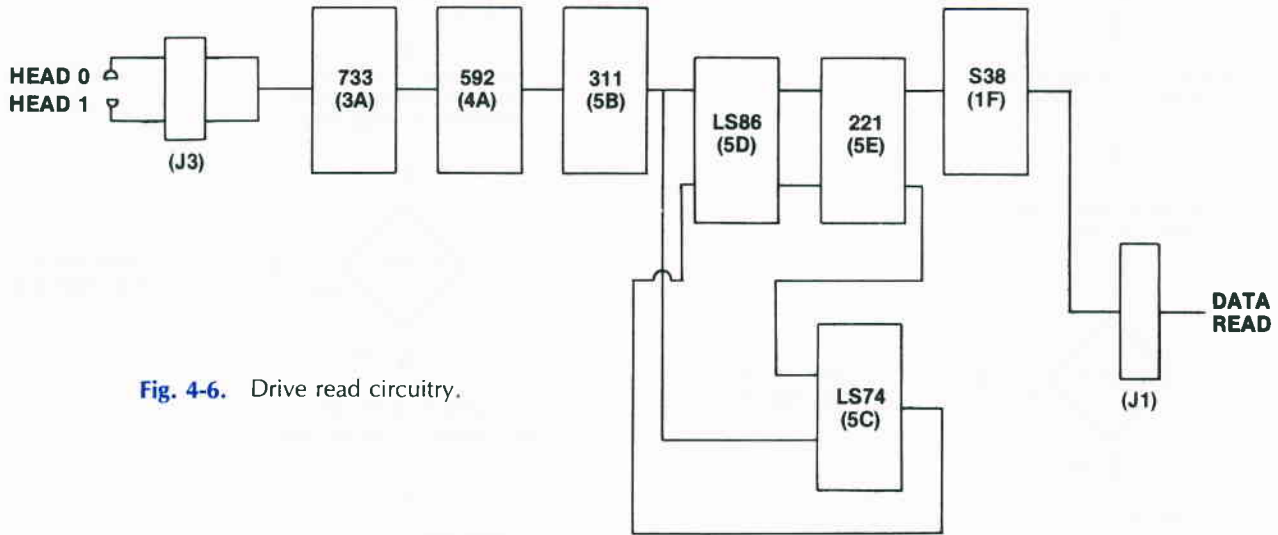


Fig. 4-6. Drive read circuitry.

Chip designation	Description	Location
221	Quad analog switch with latch	5E
311	Linear comparator	5B
592	Linear RF amplifier	4A
733	Linear video amplifier	3A
74S38	Quad 2-input NAND buffer	1F
74LS74	Dual-D flip-flop	5C
74LS86	Quad 2-input EXOR gate	5D

### SYMPTOM: Neither drive will read

Problem	Possible cause	Repair action
Data not coming out of drive	Cable bad or loose	Reseat or replace.
Bad IC on adapter card	Bad 74LS240 at U18	Replace and test.
	Bad 74LS112 at U22	Replace and test.
	Bad 74LS161 at U23	Replace and test.
	Bad 74LS112 at U25	Replace and test.
	Bad 74LS02 at U26	Replace and test.
	Bad 74S153 at U24	Replace and test.
	Bad MC4044 at U21	Replace and test.
	Bad MC4024 at U20	Replace and test.
	Bad 74LS191 at U19	Replace and test.

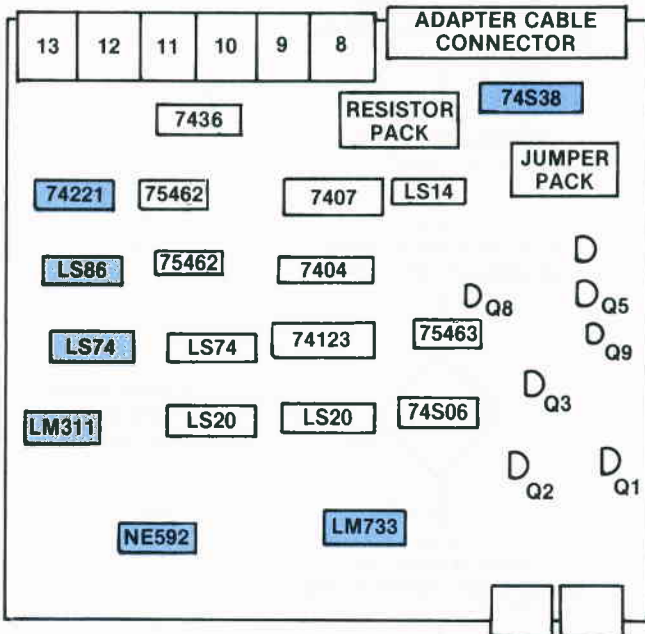
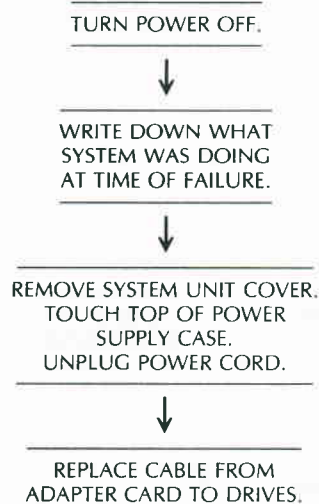
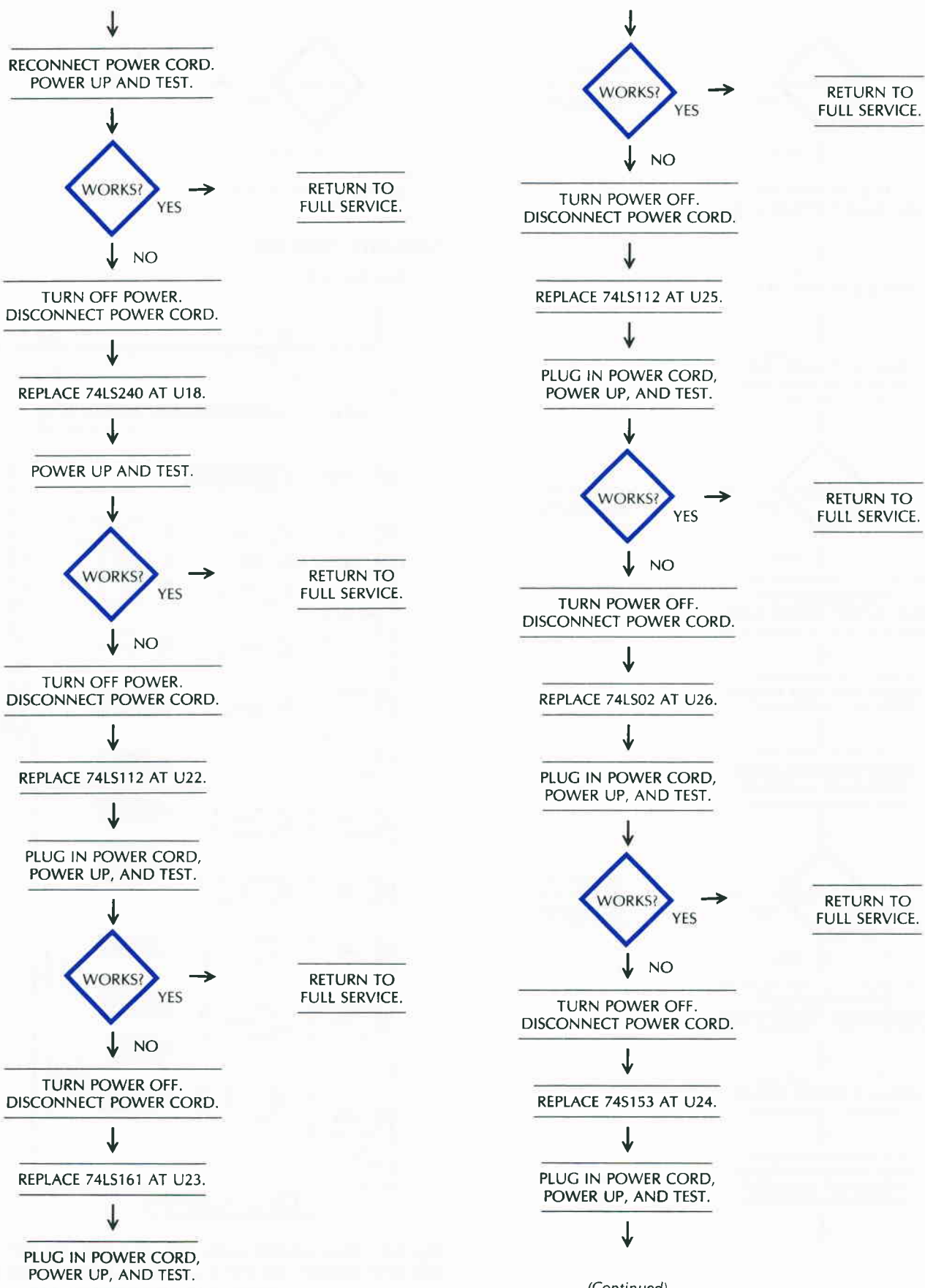


Fig. 4-7. Chip location guide. This represents the IBM PC disk drive analog card and is a guide to help you find the chips of interest.

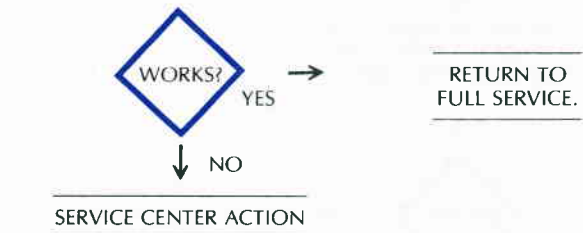
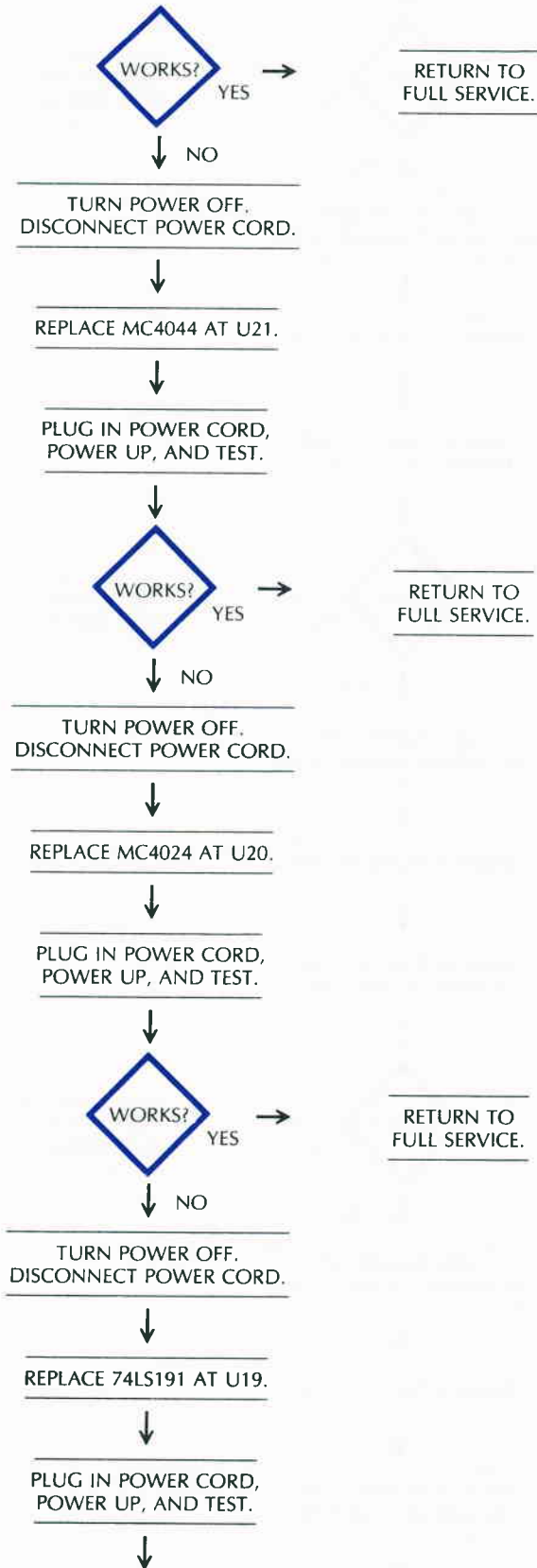
### Troubleshooting Procedure



(Continued)

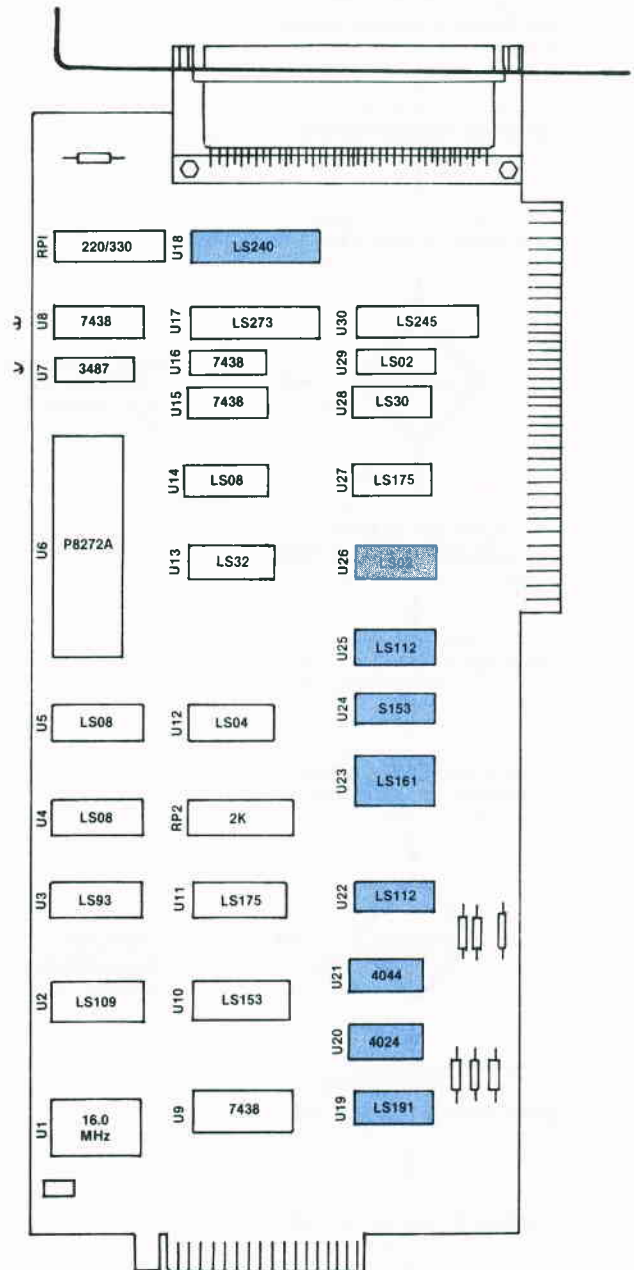


(Continued)



**Circuitry Affected**

See Fig. 4-9.



**Fig. 4-8.** Chip location guide. This represents the IBM PC disk drive adapter card and is a guide to help you find the chips of interest.

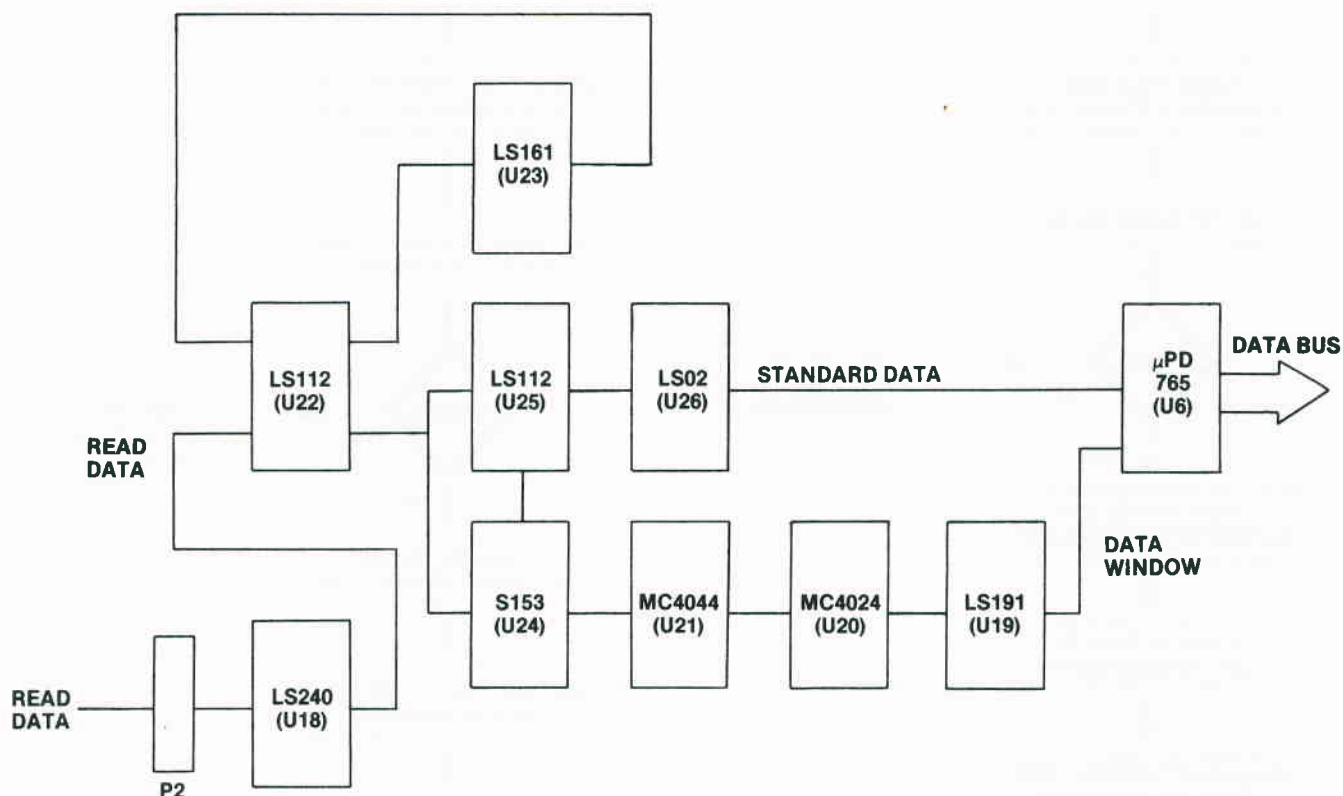


Fig. 4-9. Circuitry for "neither drive will read."

Chip designation	Description	Location
MC4024	Dual voltage-controlled multivibrator	U20
MC4044	Phase frequency detector	U21
74LS02	Quad 2-input NOR gate	U26
74LS112	Dual-JK flip-flop	U22, U25
74S153	Dual 4/1 multiplexer	U24
74LS161	4-bit binary counter	U23
74LS191	Presetable 4-bit binary UP/DOWN counter	U19
74LS240	Tri-state octal inverter buffer	U18

Problem	Possible cause	Repair action
Write signals not getting to drive electronics	Cable bad or loose Analog card connectors corroded	Check cable. Clean connectors.
Drive electronic signals improper on analog card	Bad 74LS14 at 2E Bad 74LS74 at 5C Bad 74LS06 at 2B	Replace and test. Replace and test. Replace and test.
Drive mechanics bad	Bad write head Bad head alignment	Replace and test. Align head.

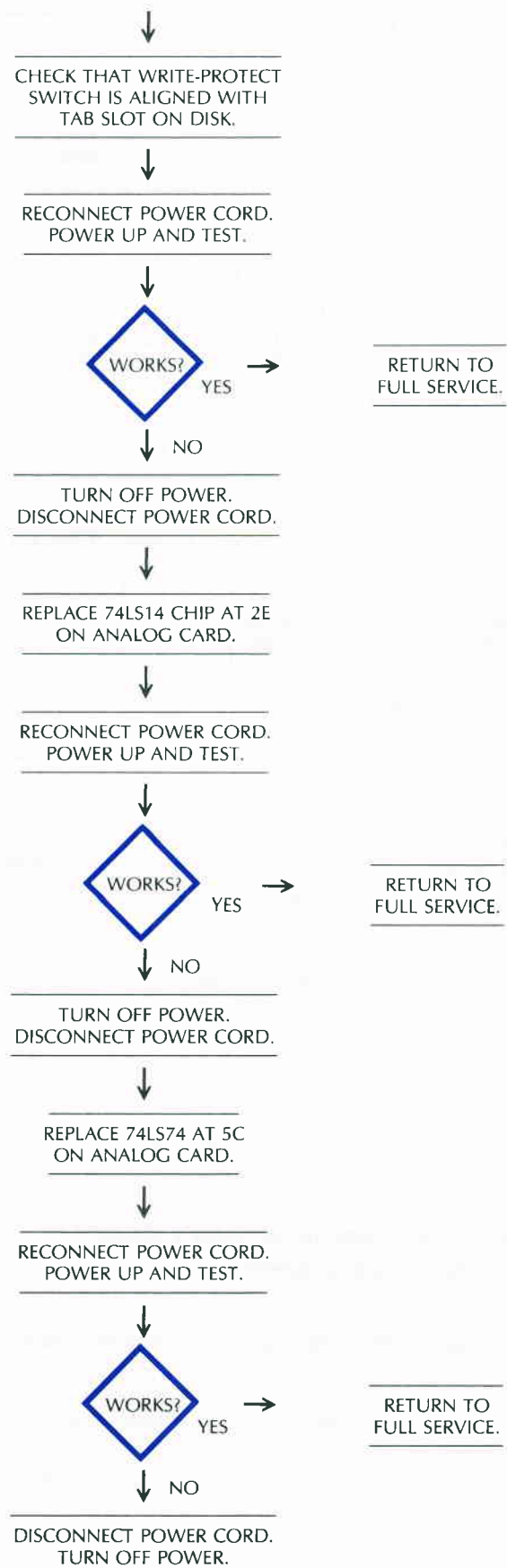
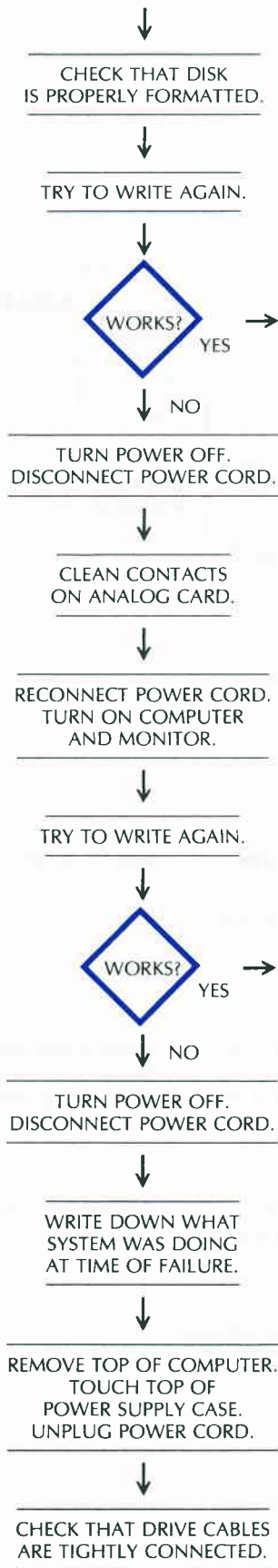
**SYMPTOM: One drive won't write (read functions properly)**

Problem	Possible cause	Repair action
Disk is write protected	Write-protect tab installed	Remove write-protect tab.
	Write-protect switch bad	Replace switch.
Drive can't tell where to write	Disk not formatted	Format disk.

**Troubleshooting Procedure**



(Continued)



(Continued)

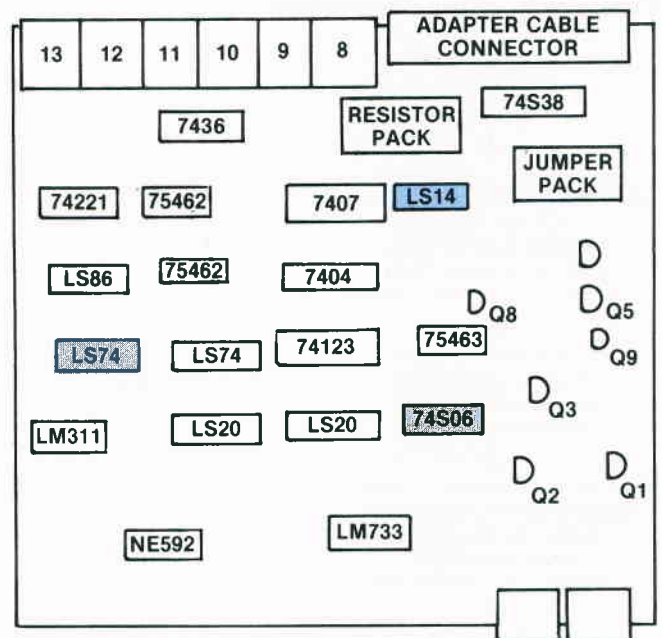
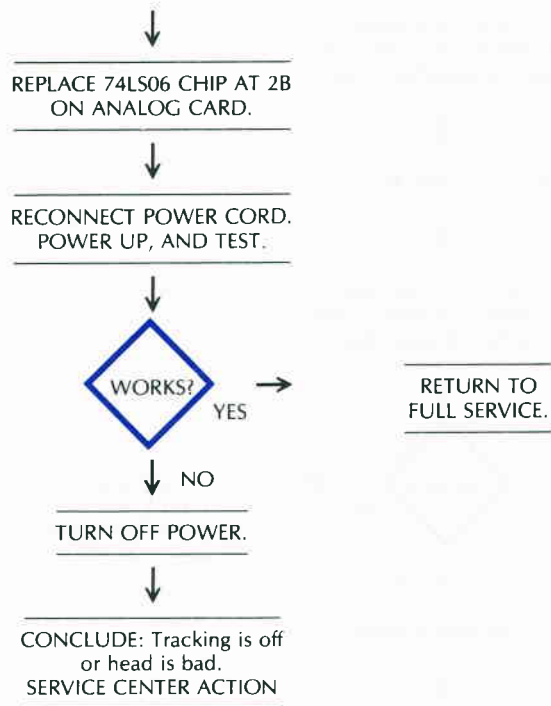


Fig. 4-11. Chip location guide. This represents the IBM PC disk drive analog card and is a guide to help you find the chips of interest.

**Circuitry Affected**

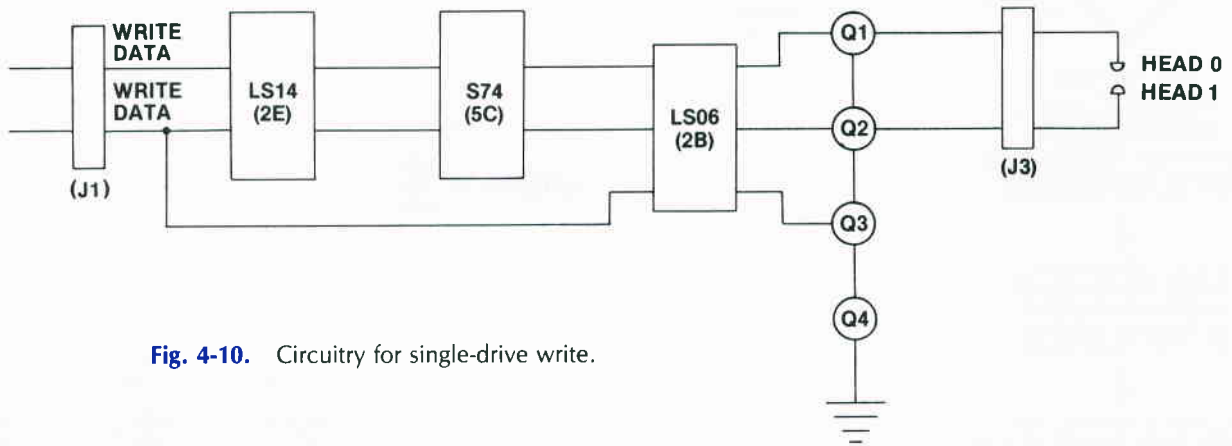


Fig. 4-10. Circuitry for single-drive write.

Chip designation	Description	Location
74LS14	Hex inverter Schmitt trigger	2E
74LS74	Dual-D flip-flop	5C
74LS06	Hex inverter buffer/driver	2B

**SYMPTOM: Neither drive will write (read functions properly)**

Problem	Possible cause	Repair action
Write signals not getting to drive electronics	Cable bad or loose	Check cable.
	Adapter connectors corroded	Clean connectors.

Problem	Possible cause	Repair action
Drive electronic signals improper on adapter card	Bad 74LS175 at U11	Replace and test.
	Bad 7438 at U9	Replace and test.

### Troubleshooting Procedure

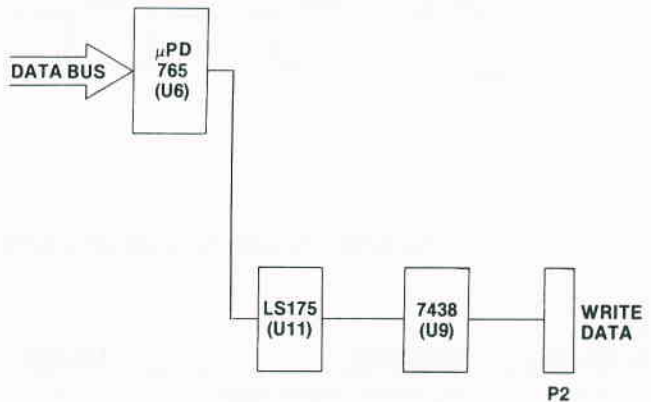
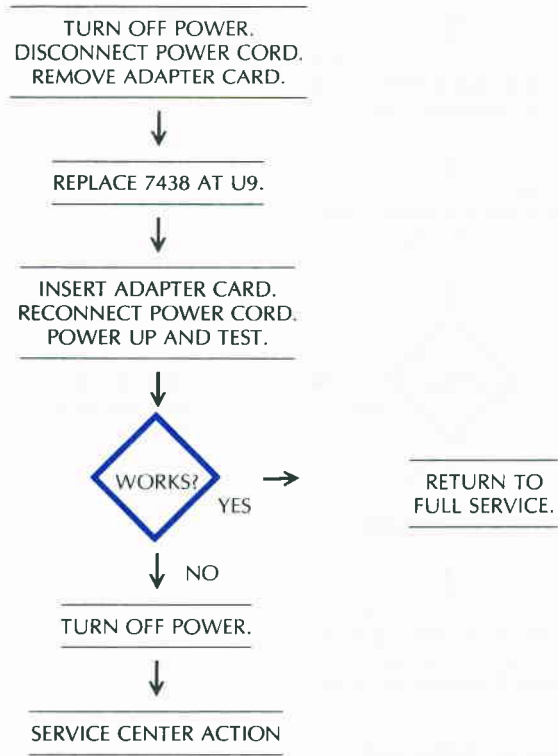
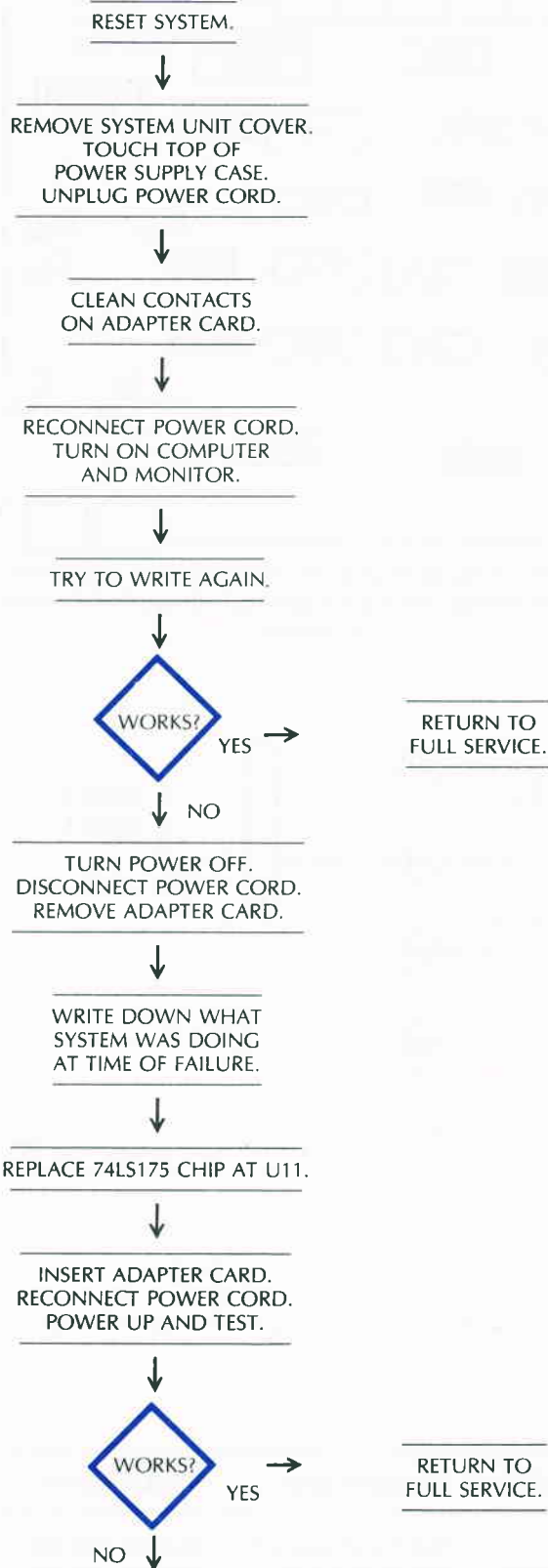
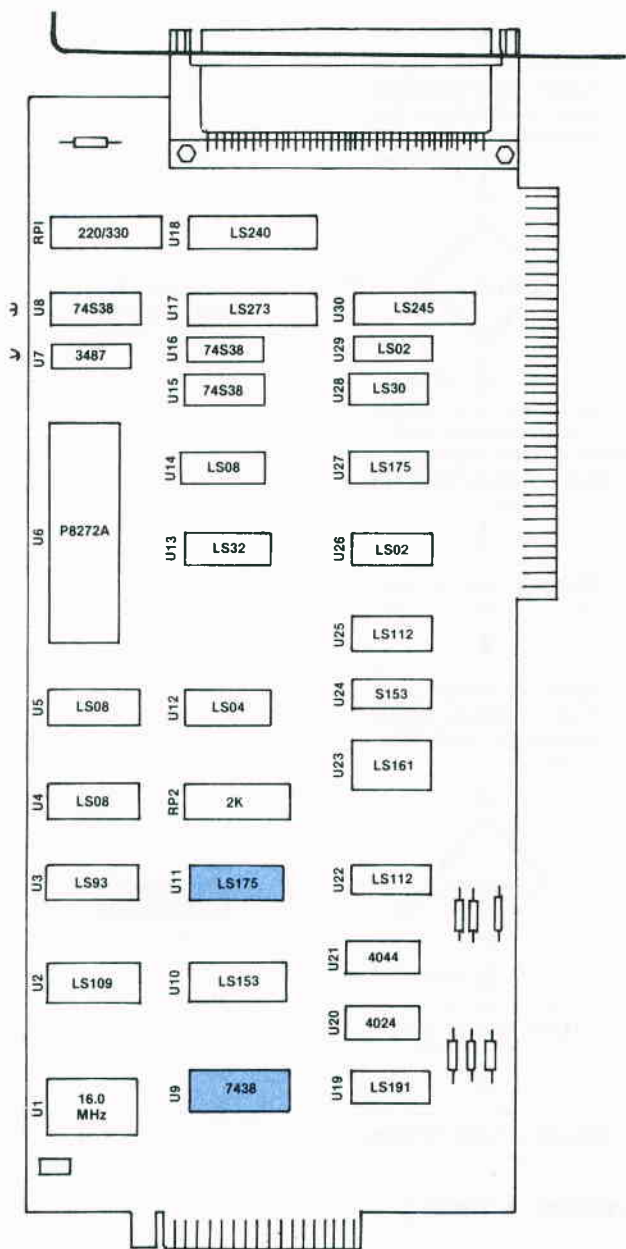


Fig. 4-12. Circuitry for "neither drive will write."

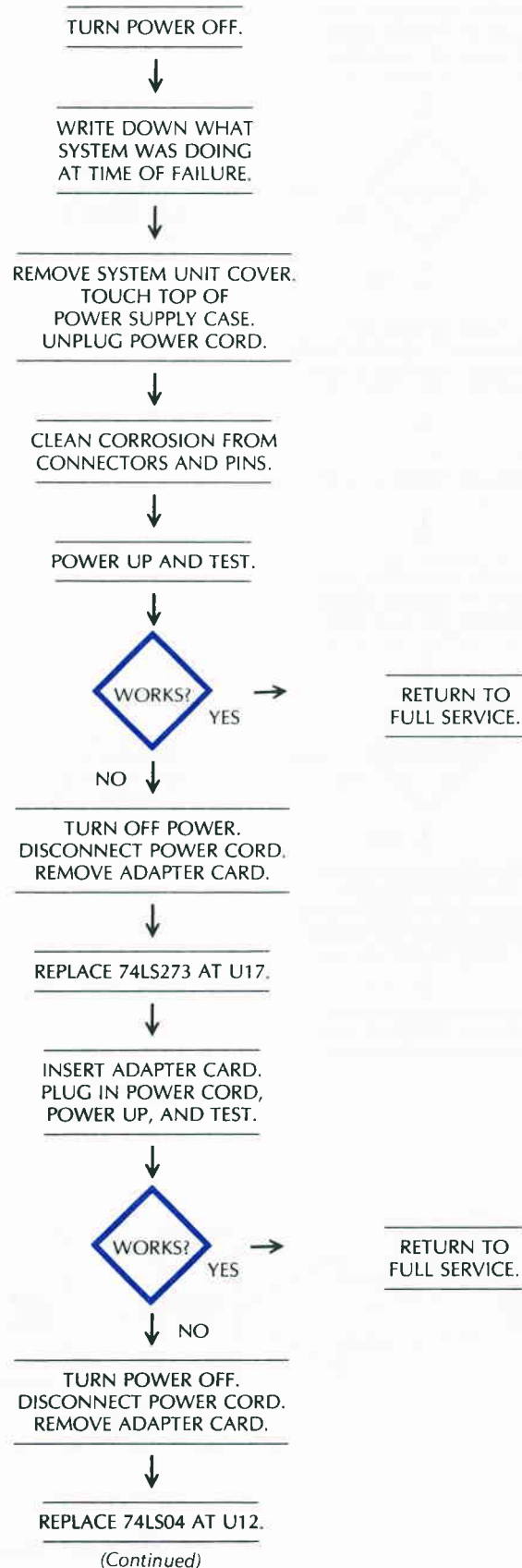
### Circuitry Affected

Chip designation	Description	Location
74LS175	Quad-D flip-flop	U11
7438	Quad 2-input NAND buffer	U9



**Fig. 4-13.** Chip location guide. This represents the IBM PC disk drive adapter card and is a guide to help you find the chips of interest.

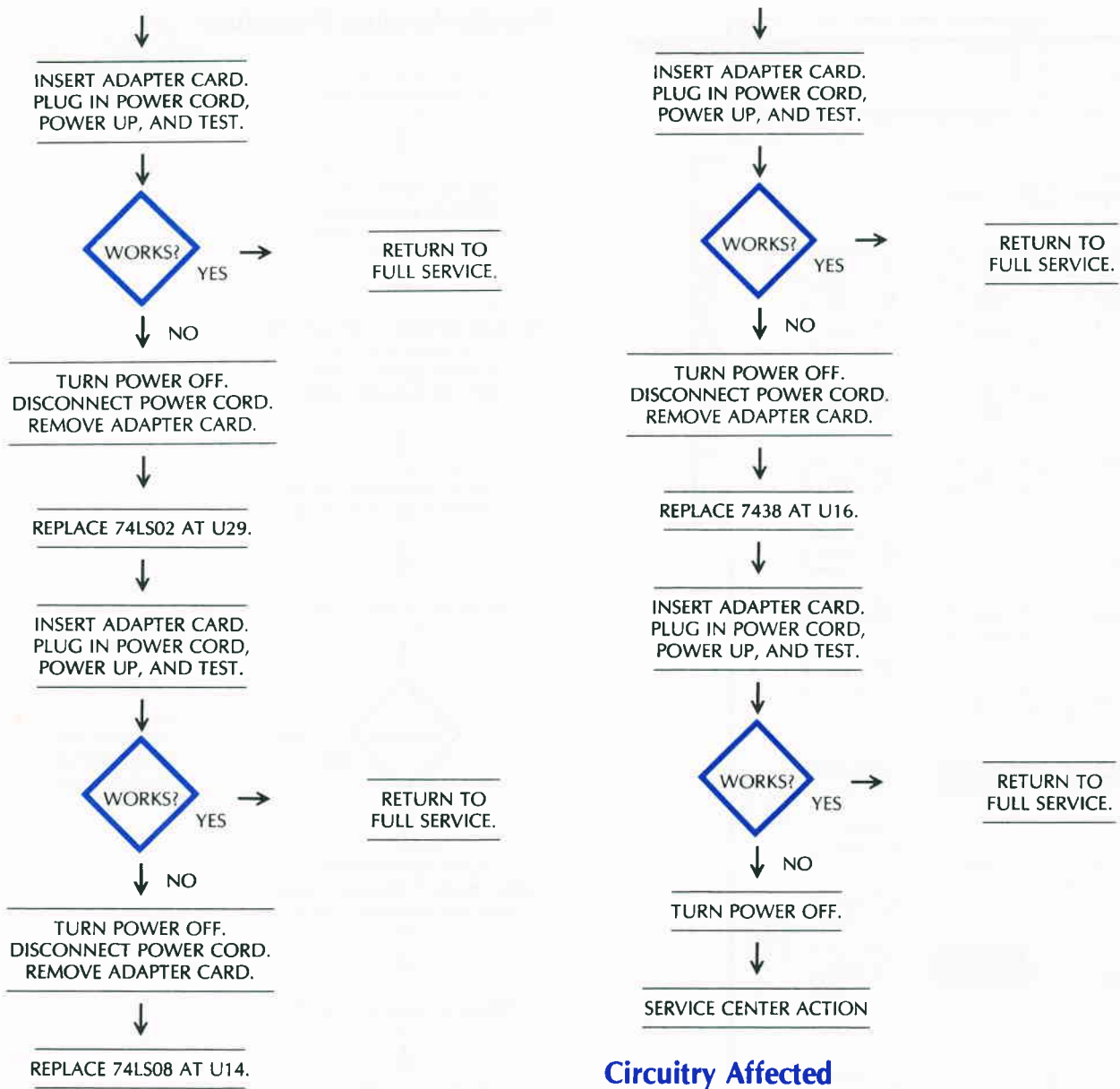
### Troubleshooting Procedure



### SYMPTOM: Drives can't be accessed

Problem	Possible cause	Repair action
Signals not getting into analog card	Corrosion on cable connector pins	Clean cable connector pins.
Adapter electronics not working	Bad 74LS273 at U17 Bad 74LS04 at U12 Bad 74LS02 at U29 Bad 74LS08 at U14 Bad 7438 at U16	Replace and test. Replace and test. Replace and test. Replace and test. Replace and test.

(Continued)



**Circuitry Affected**

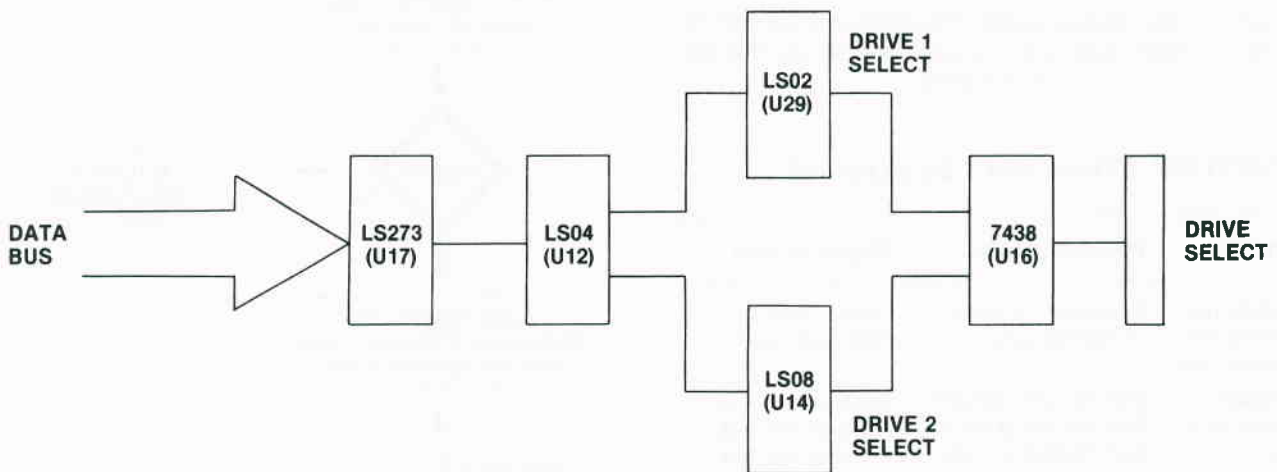
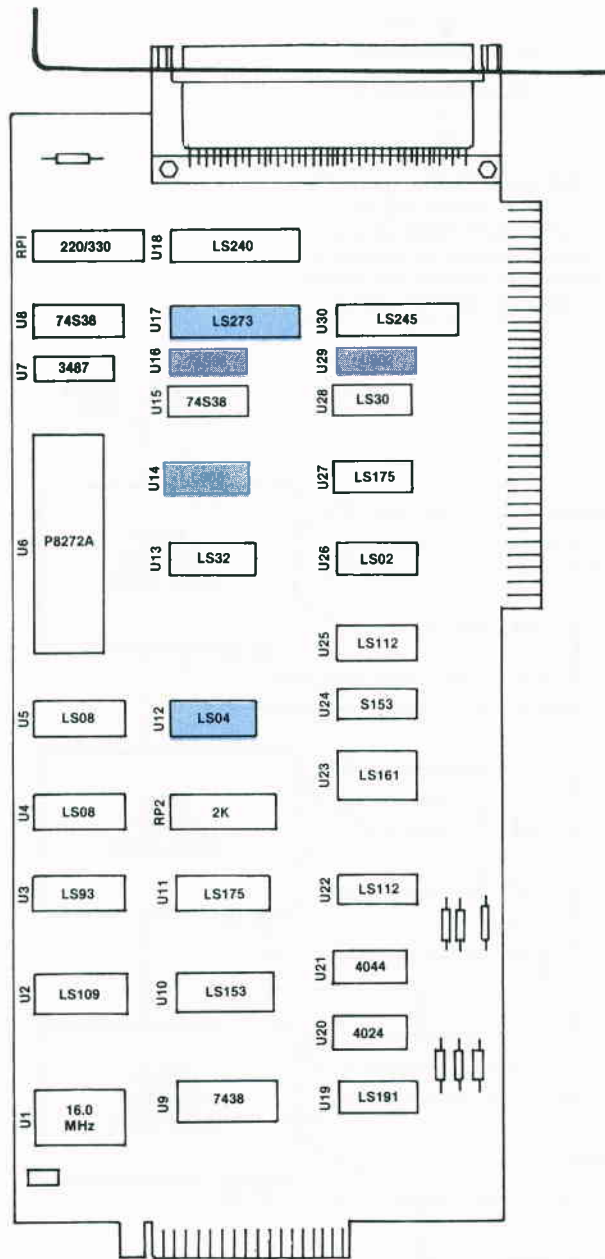


Fig. 4-14. Drive select circuitry.

Chip designation	Description	Location
74LS02	Quad 2-input NOR gate	U29
74LS04	Hex inverter	U12
74LS08	Quad 2-input AND gate	U14
7438	Quad 2-input NAND buffer	U16
74LS273	Octal-D flip-flop	U17

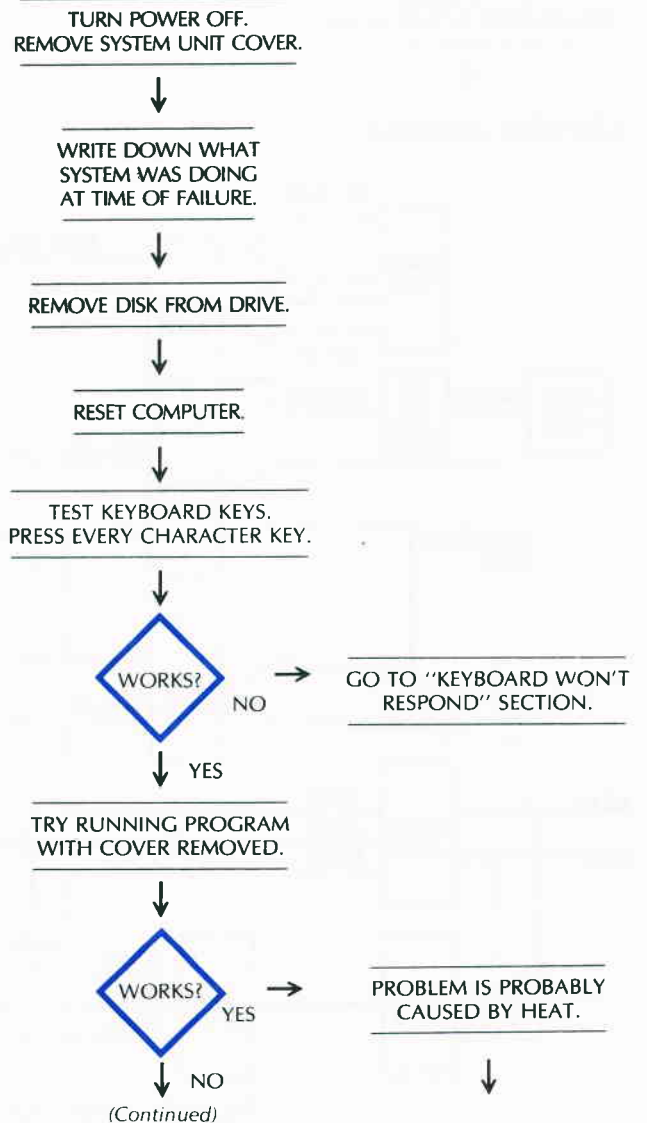


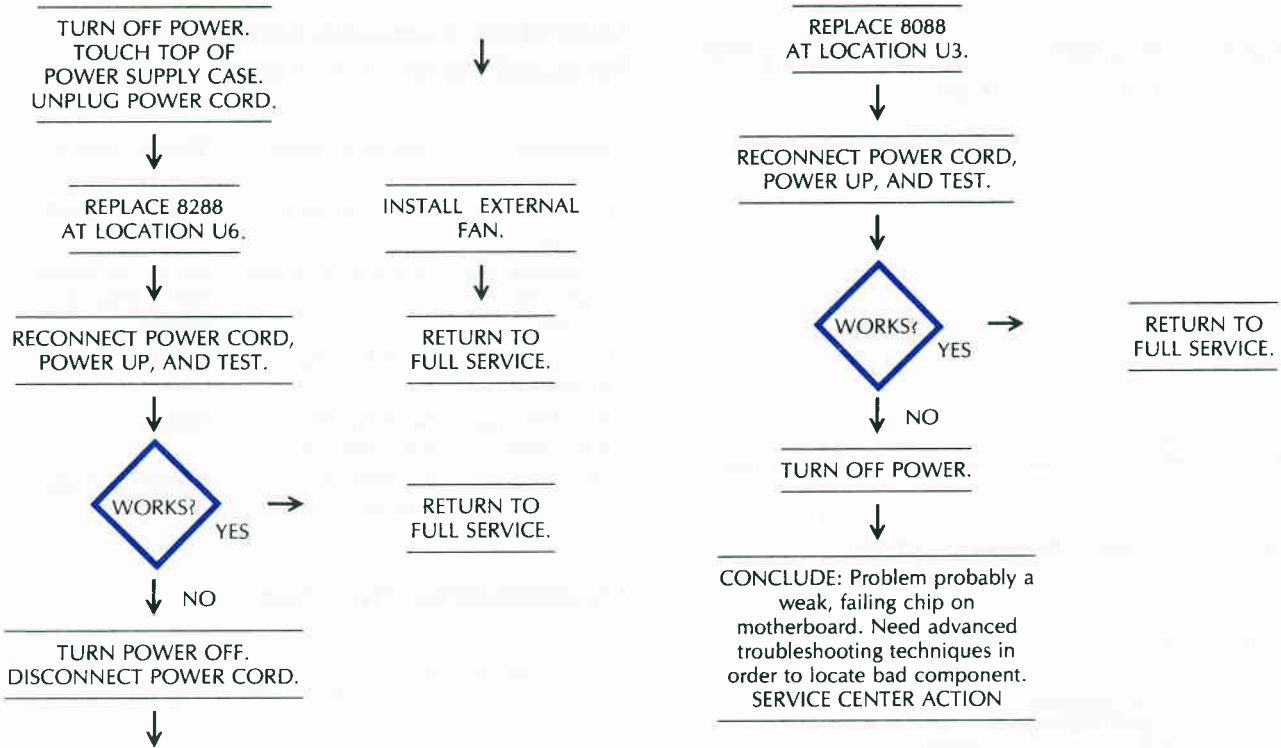
**Fig. 4-15.** Chip location guide. This represents the IBM PC disk drive adapter card and is a guide to help you find the chips of interest.

### SYMPTOM: Computer locks up, keyboard entries won't work

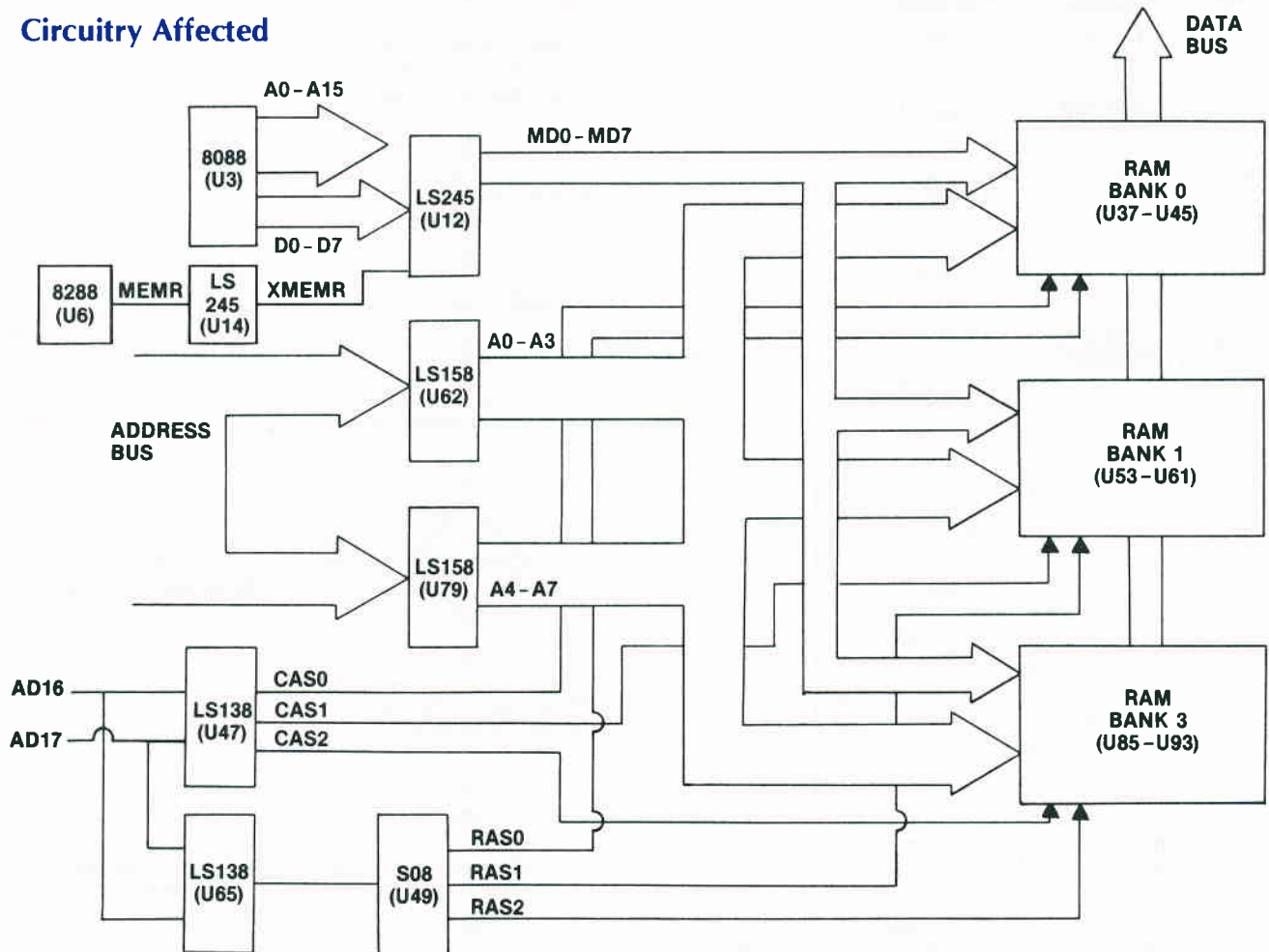
Problem	Possible cause	Repair action
Programming lock-out	Error in program	Debug program.
No output from keyboard circuitry	Failure in keyboard circuitry	Go to "Keyboard won't respond" section.
Heat problem on motherboard	Bad RAM chip	Replace and test.
No RAM chip-select signal	Bad 8288 chip at location U6	Replace and test.
CPU failure	Bad 8088 chip at location U3	Replace and test.

### Troubleshooting Procedure





**Circuitry Affected**



**Fig. 4-16.** Circuitry for "computer locks up" problem.

Chip designation	Description	Location
8088	Microprocessor (central processing unit)	U3
8288	Bus controller	U6
74S08	Quad 2-input AND gate	U49
74LS138	1/8 decoder/demultiplexer	U47, U65
74LS158	Quad 2-input data selector multiplexer	U62, U79
74LS245	Tri-state octal transceiver	U12

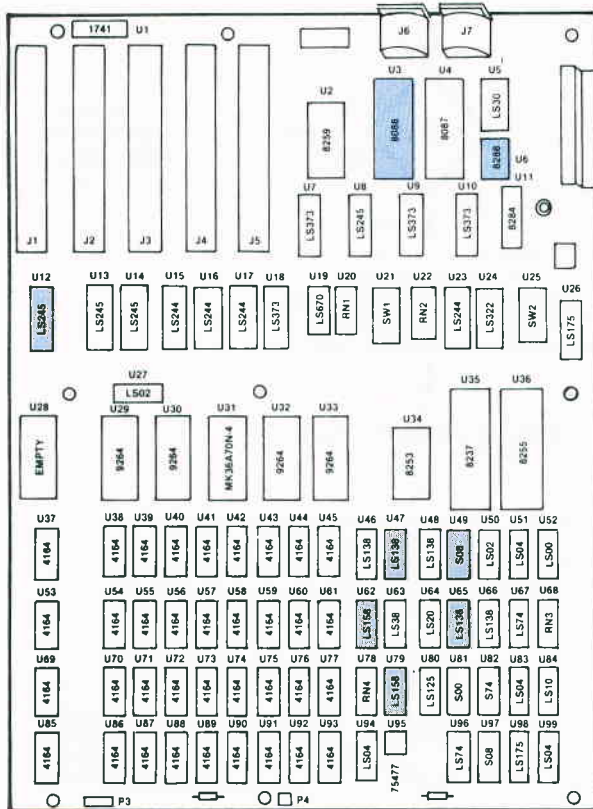


Fig. 4-17. Chip location guide. This represents the IBM PC system board and is a guide to help you find the chips of interest.

## DISPLAY PROBLEMS

Symptom Category	Page
Monochrome monitor and adapter card	
No display	95
No vertical synchronization (sync)	98
No horizontal synchronization (sync)	100
Bad characters displayed	101
No lo-res display or no hi-res display	104
Color/graphics monitor and adapter card	
No display	106
No vertical synchronization (sync)	110

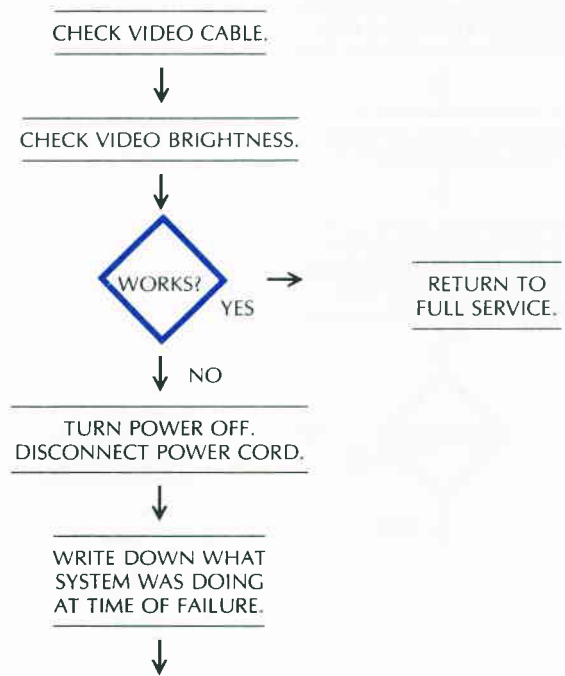
No horizontal synchronization (sync)	112
No text, but graphics works	113
Bad characters displayed	114
Bad or no color	118
No hi-res text, no lo-res text, or no graphics	120

## MONOCHROME MONITOR AND ADAPTER CARD

### SYMPTOM: No display

Problem	Possible cause	Repair action
No video into monitor	Bad cable	Reseat or replace.
Video signal too small	Brightness out of adjustment	Adjust brightness.
	Bad monitor	Check and replace if necessary.
No video signal being generated	Bad 74LS244 at U64 Bad 74S74 at U101 Bad 74S86 at U54 Bad MK36000 at U33 Bad 74LS273 at U34 Bad 6845 at U35	Replace and test. Replace and test. Replace and test. Replace and test. Replace and test.

### Troubleshooting Procedure



(Continued)

REMOVE SYSTEM UNIT COVER.  
TOUCH TOP OF  
POWER SUPPLY CASE.



DISCONNECT ALL PERIPHERAL  
HARDWARE EXCEPT  
VIDEO INTERFACE.



CONNECT MONITOR TO IBM PC.



REMOVE MONOCHROME  
ADAPTER CARD.



REPLACE 74LS244 AT U64.



REINSTALL ADAPTER CARD.  
RECONNECT POWER CORD.  
POWER UP AND TEST.



RETURN TO  
FULL SERVICE.



TURN POWER OFF.  
DISCONNECT POWER CORD.  
REMOVE ADAPTER CARD.



REPLACE 74S74 AT U101.



INSERT ADAPTER CARD.  
RECONNECT POWER CORD.  
POWER UP AND TEST.



RETURN TO  
FULL SERVICE.



TURN POWER OFF.  
DISCONNECT POWER CORD.  
REMOVE ADAPTER CARD.



REPLACE 74S86 AT U54.



INSERT ADAPTER CARD.  
RECONNECT POWER CORD.  
POWER UP AND TEST.



RETURN TO  
FULL SERVICE.



TURN POWER OFF.  
DISCONNECT POWER CORD.  
REMOVE ADAPTER CARD.



REPLACE MK36000 AT U33.



INSERT ADAPTER CARD.  
RECONNECT POWER CORD.  
POWER UP AND TEST.



RETURN TO  
FULL SERVICE.



TURN POWER OFF.  
DISCONNECT POWER CORD.  
REMOVE ADAPTER CARD.

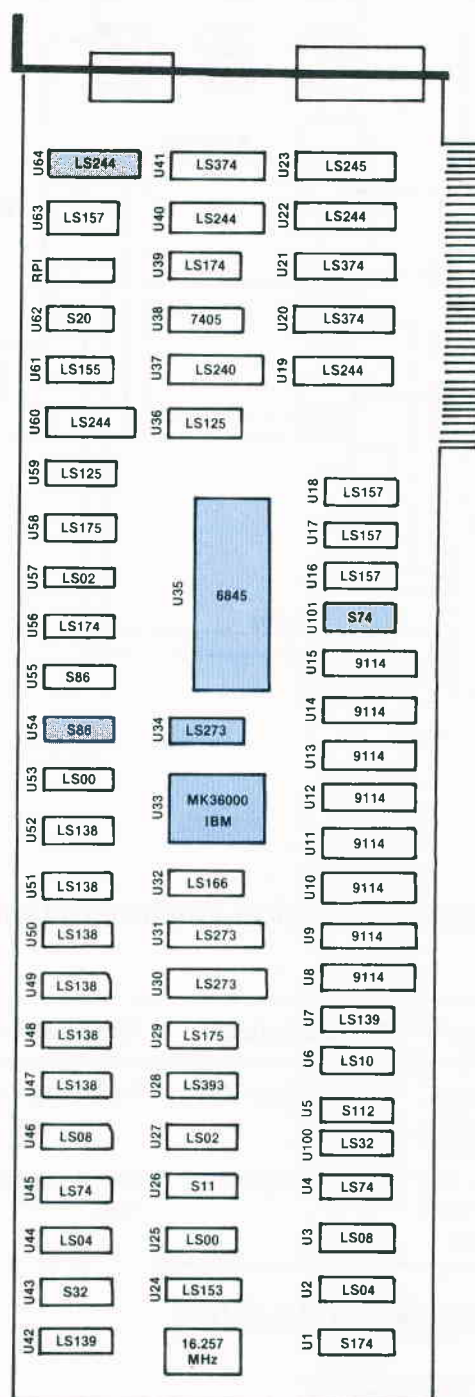
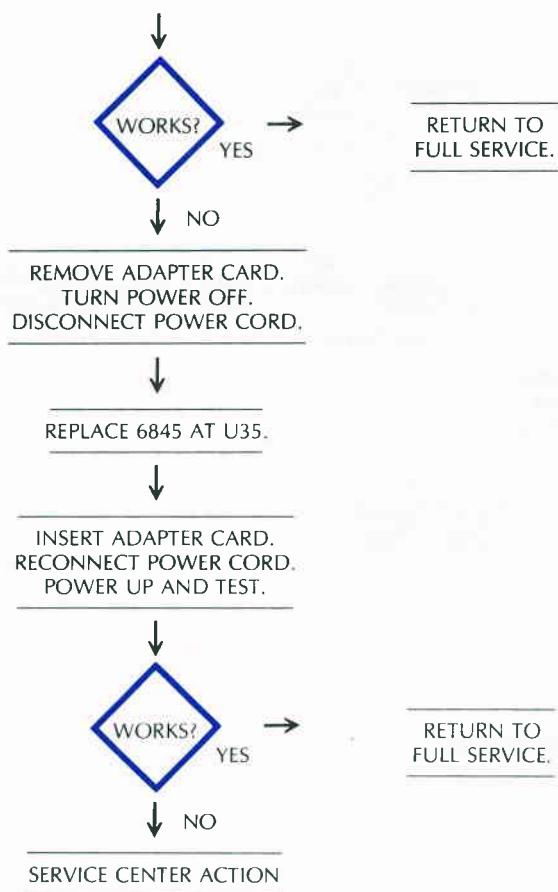


REPLACE 74LS273 AT U34.



INSERT ADAPTER CARD.  
RECONNECT POWER CORD.  
POWER UP AND TEST.

(Continued)



### Circuitry Affected

See Fig. 4-19.

Chip designation	Description	Location
6845	CRT controller	U35
74S74	Dual-D flip-flop	U101
74S86	Quad 2-input EXOR gate	U54
74LS244	Tri-state octal buffer	U64
74LS273	Octal-D flip-flop	U34
MK36000	Character generator ROM	U33

**Fig. 4-18.** Chip location guide. This represents the IBM PC monochrome adapter card and is a guide to help you find the chips of interest.

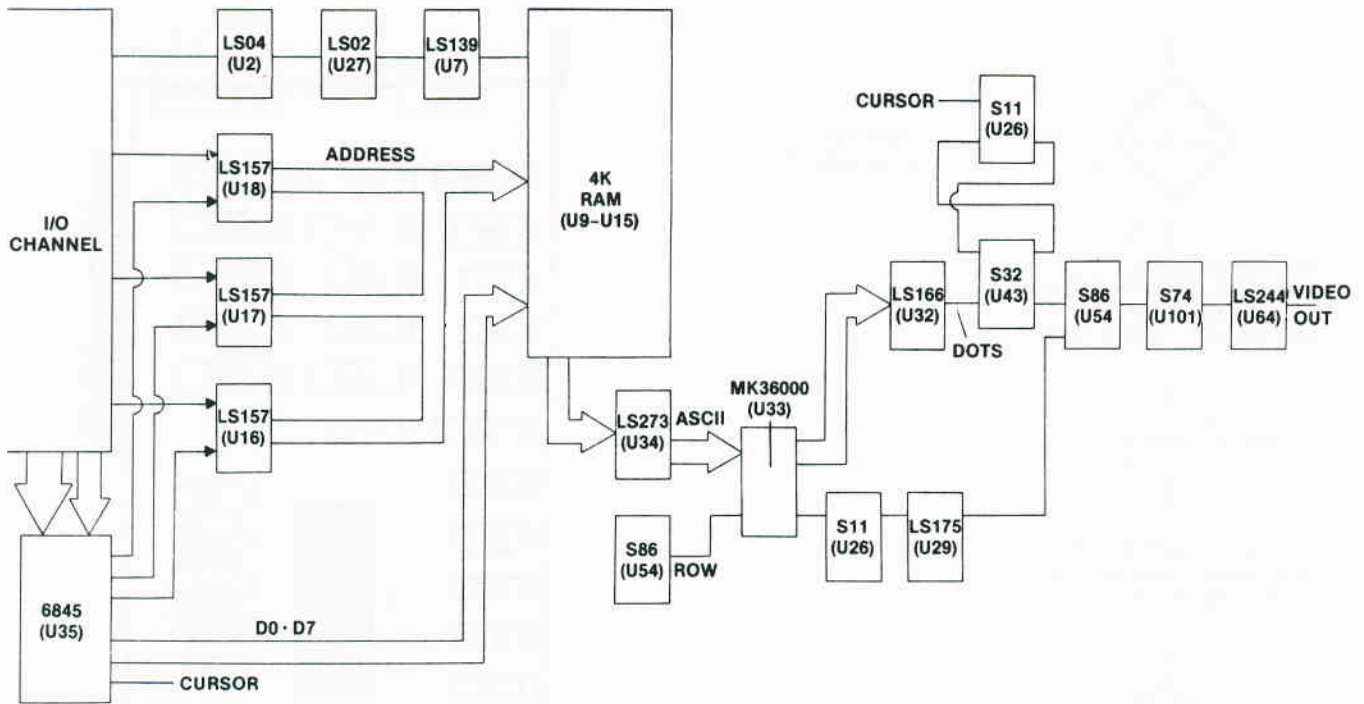
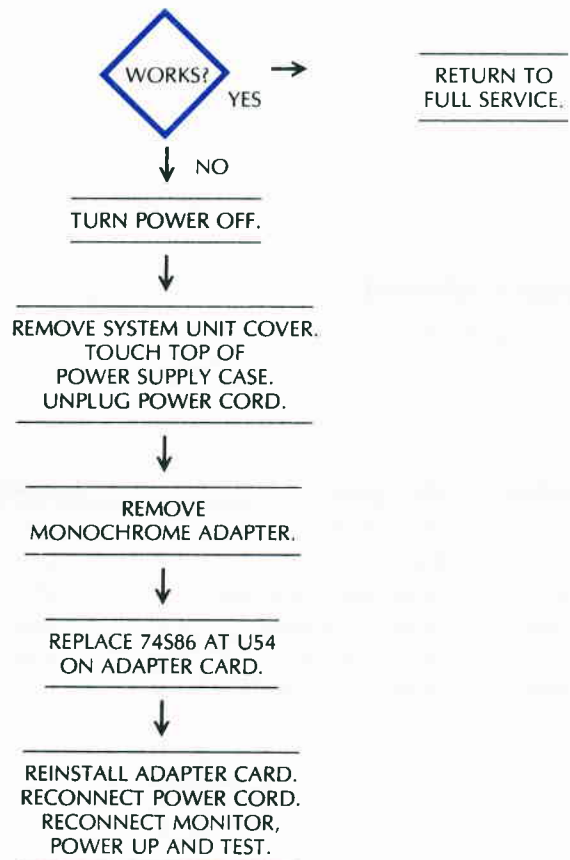
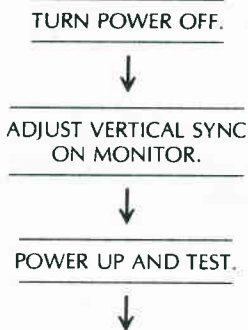


Fig. 4-19. Monochrome video circuitry.

**SYMPTOM: No vertical synchronization (sync)**

Problem	Possible cause	Repair action
No vertical sync signal to monitor	Bad 74S86 at U54	Replace and test.
Monitor not in sync with computer	Monitor adjustment	Adjust vertical hold.

**Troubleshooting Procedure**



(Continued)

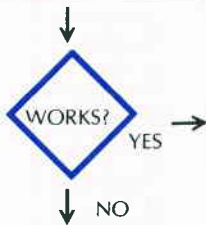


**SYMPTOM: No horizontal synchronization (sync)**

Problem	Possible cause	Repair action
Monitor not in sync	Monitor needs adjusting	Adjust horizontal hold.
Horizontal sync not being produced	Bad 74S74 at U101	Replace and test.
	Bad 74LS32 at U100	Replace and test.
	Bad 74LS08 at U3	Replace and test.
Monitor not functioning	Bad monitor	Check and replace if necessary.

**Troubleshooting Procedure**

CHECK MONITOR HORIZONTAL HOLD (SYNC) CONTROL.



TURN POWER OFF. DISCONNECT POWER CORD.

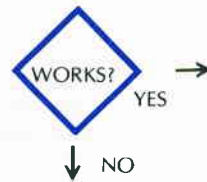
WRITE DOWN WHAT SYSTEM WAS DOING AT TIME OF FAILURE.

REMOVE SYSTEM UNIT COVER. TOUCH TOP OF POWER SUPPLY CASE.

DISCONNECT MONOCHROME ADAPTER CARD.

REPLACE 74S74 AT U101.

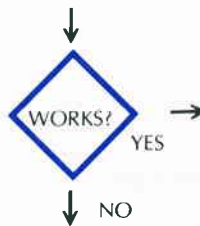
RECONNECT ADAPTER CARD. RECONNECT MONITOR. RECONNECT POWER CORD. POWER UP AND TEST.



TURN POWER OFF. DISCONNECT POWER CORD. DISCONNECT MONITOR. DISCONNECT ADAPTER CARD.

REPLACE 74LS32 AT U100.

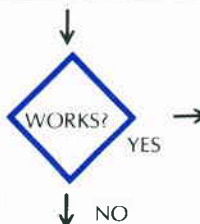
RECONNECT POWER CORD. RECONNECT ADAPTER CARD. RECONNECT MONITOR. POWER UP AND TEST.



TURN POWER OFF. DISCONNECT POWER CORD. DISCONNECT MONITOR. DISCONNECT ADAPTER CARD.

REPLACE 74LS08 AT U3.

RECONNECT ADAPTER CARD. RECONNECT MONITOR. RECONNECT POWER CORD. POWER UP, AND TEST.



TURN POWER OFF. DISCONNECT POWER CORD.

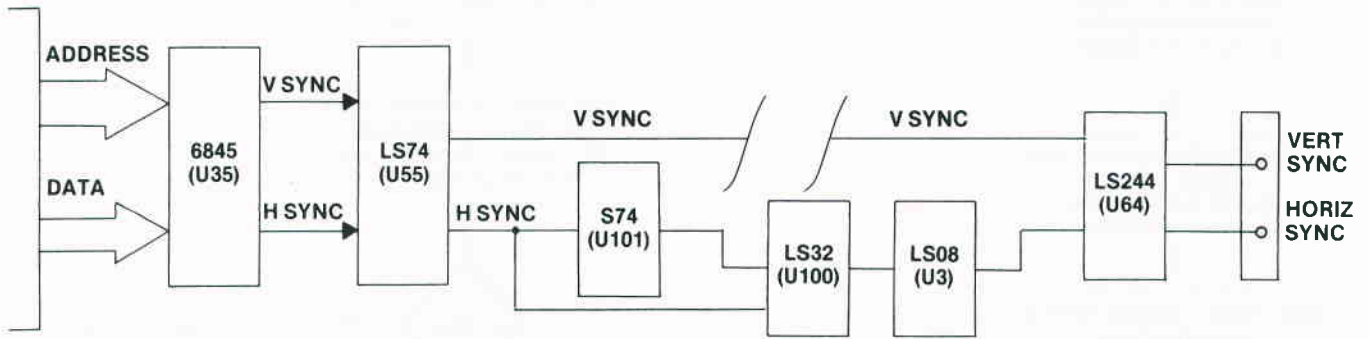
CONCLUDE: Problem is probably in the monitor or at least not in an IC. SERVICE CENTER ACTION

RETURN TO FULL SERVICE.

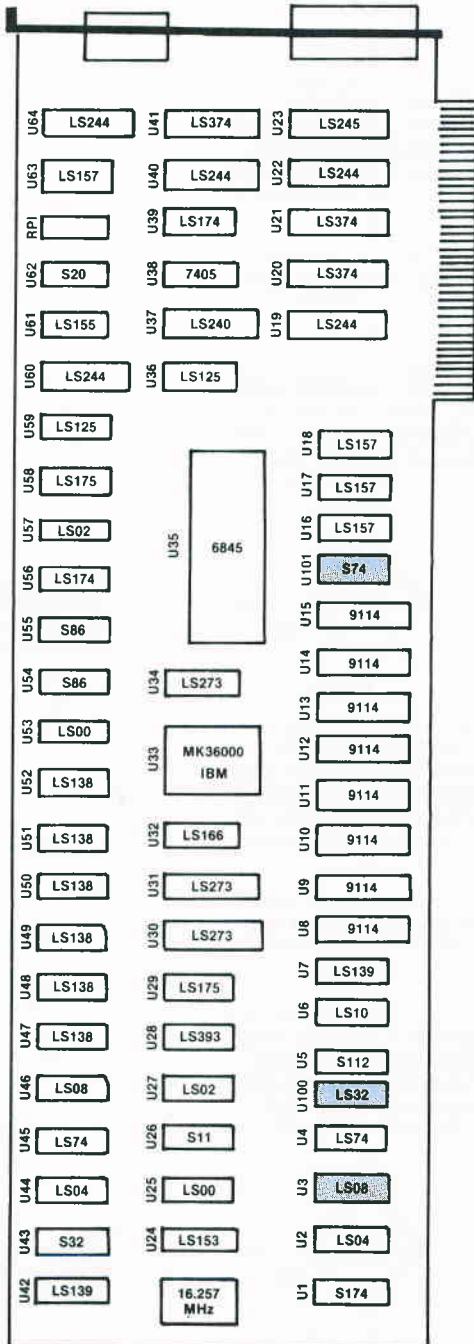
RETURN TO FULL SERVICE.

RETURN TO FULL SERVICE.

**Circuitry Affected**



**Fig. 4-22.** Horizontal synchronization circuitry.



Chip designation	Description	Location
74LS08	Quad 2-input AND gate	U3
74LS32	Quad 2-input OR gate	U100
74S74	Dual-D flip-flop	U101

**Fig. 4-23.** Chip location guide. This represents the IBM PC monochrome adapter card and is a guide to help you find the chips of interest.

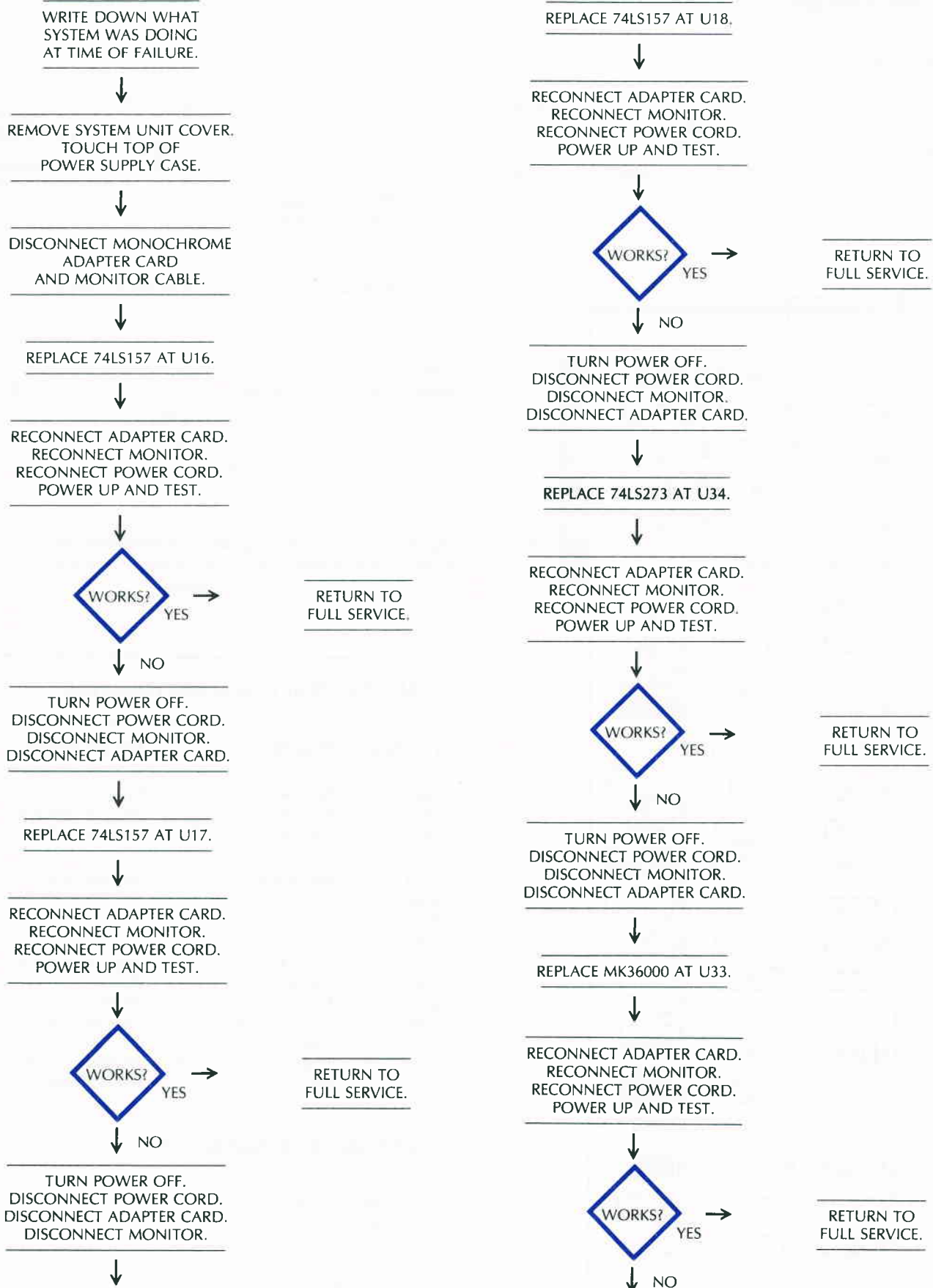
**SYMPTOM: Bad characters displayed**

Problem	Possible cause	Repair action
Data not being latched properly	Bad 74LS157 at U16	Replace and test.
	Bad 74LS157 at U17	Replace and test.
	Bad 74LS157 at U18	Replace and test.
Data not staying in RAM correctly	Bad RAM IC at U9- U15	Replace and test.
Characters not generated properly	Bad 74LS273 at U34	Replace and test.
	Bad MK36000 at U33	Replace and test.
	Bad 74S86 at U54	Replace and test.
	Bad 74LS166 at U32	Replace and test.
	Bad 74S11 at U26	Replace and test.
	Bad 74LS175 at U29	Replace and test.
	Bad 74S32 at U43	Replace and test.
	Bad 74S32 at U43	Replace and test.

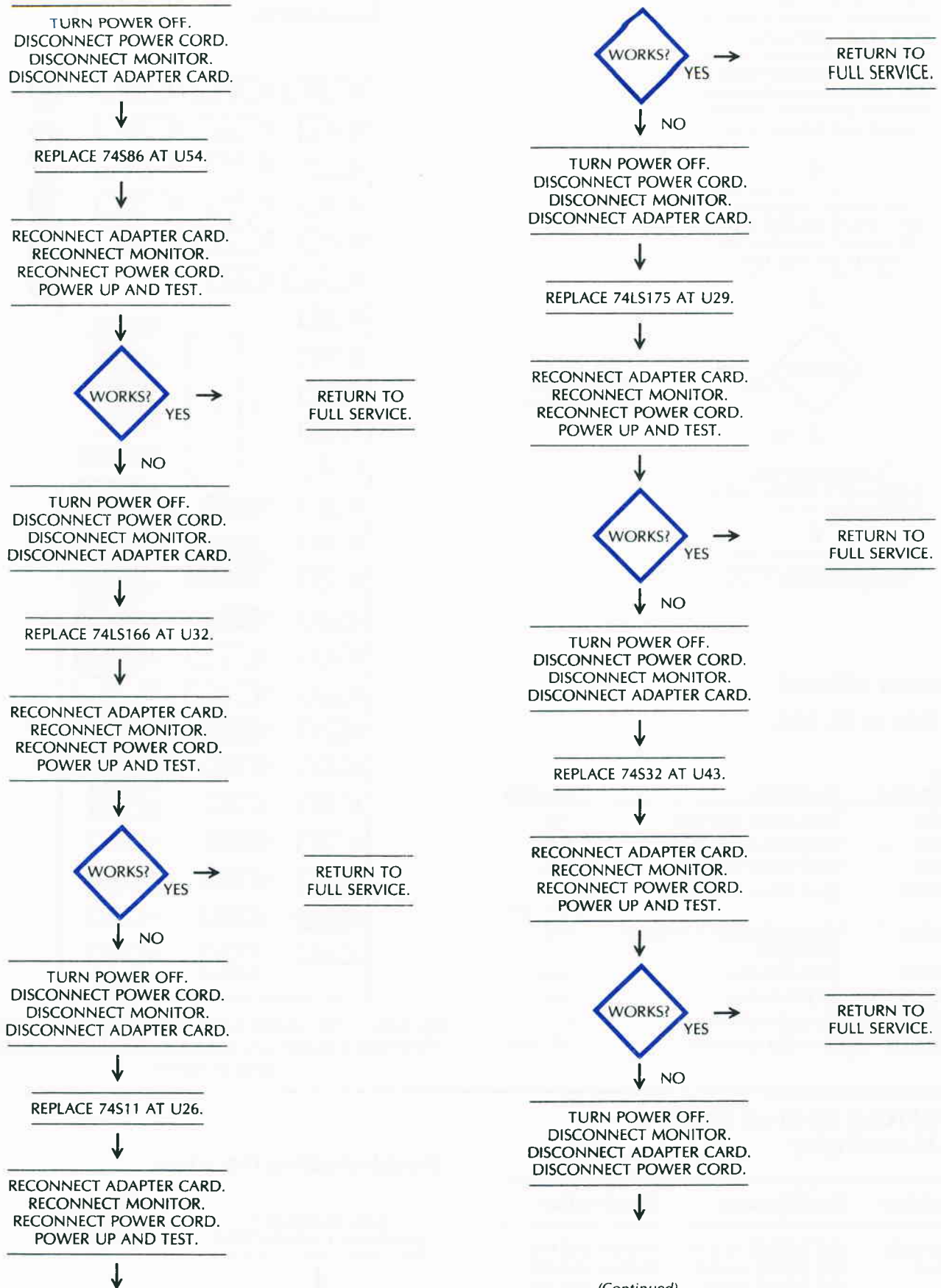
**Troubleshooting Procedure**

TURN POWER OFF.  
DISCONNECT POWER CORD.

↓  
(Continued)



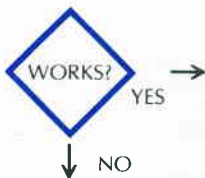
(Continued)



(Continued)

CONCLUDE: Problem is likely to be in the RAM section.  
 Replace each RAM chip starting with U9 and working through U15. Test after each replacement. When the problem is corrected, the last chip replaced is bad.

RECONNECT MONITOR.  
 RECONNECT ADAPTER CARD.  
 RECONNECT POWER CORD.  
 POWER UP AND TEST.



RETURN TO FULL SERVICE.

TURN POWER OFF.  
 DISCONNECT POWER CORD.

SERVICE CENTER ACTION

### Circuitry Affected

Refer to Fig. 4-19.

Chip designation	Description	Location
74S11	Triple 3-input AND gate	U26
74S32	Quad 2-input OR gate	U43
74S86	Quad 2-input EXOR gate	U54
74LS157	Quad 2-input multiplexer	U16, U17, U18
74LS166	8-bit serial/parallel in, serial-out shift register	U32
74LS175	Quad-D flip-flop	U29
74LS273	Octal-D flip-flop	U34
MK36000	8K x 8-bit static ROM	U33
2114/9114	1K x 4-bit static RAM	U9-U15

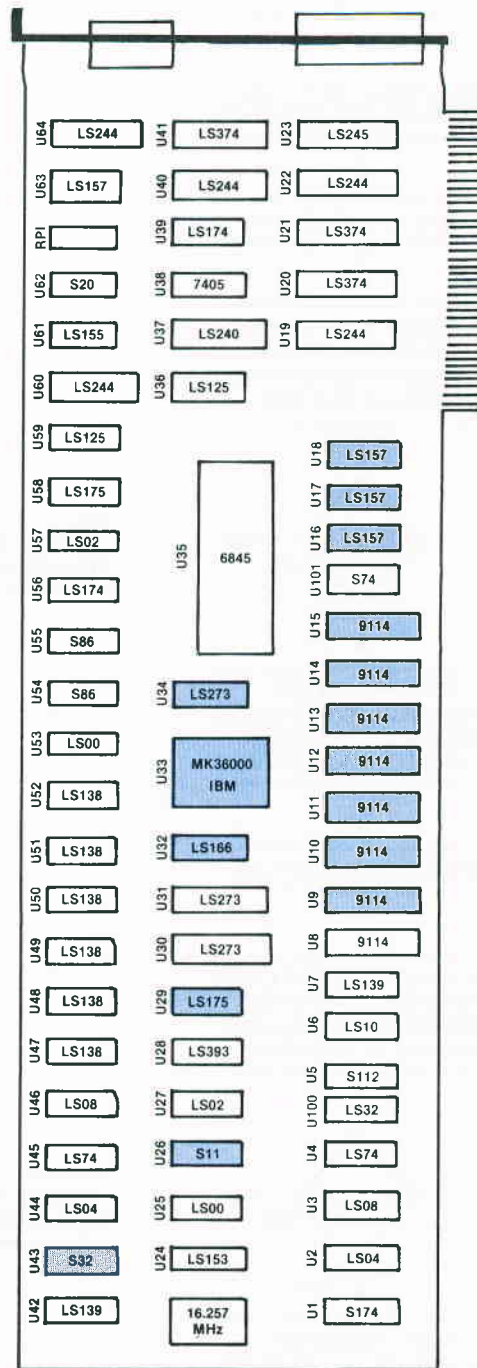


Fig. 4-24. Chip location guide. This represents the IBM PC monochrome adapter card and is a guide to help you find the chips of interest.

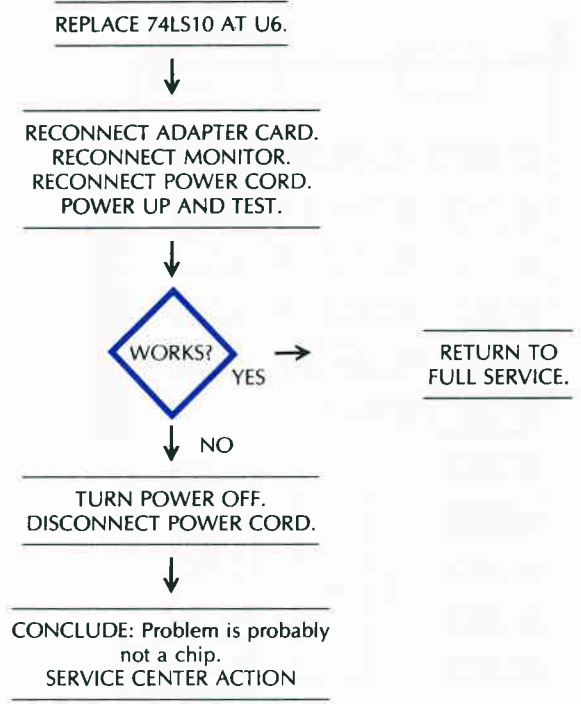
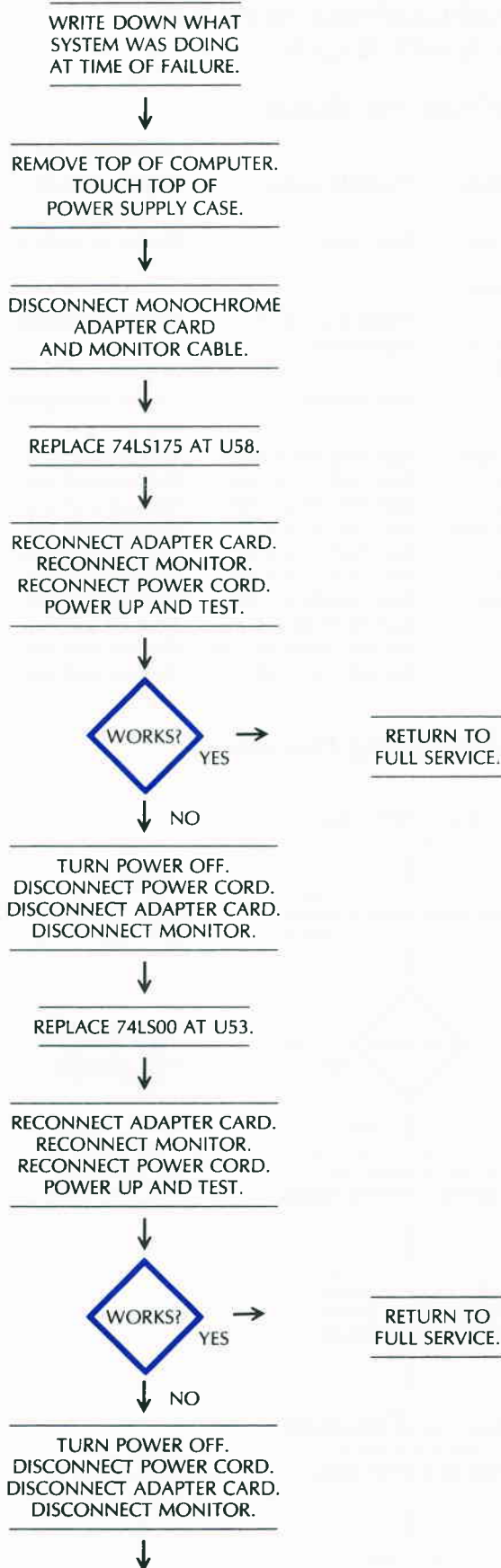
### SYMPTOM: No lo-res display or no hi-res display

Problem	Possible cause	Repair action
No mode select	Bad 74LS175 at U58 Bad 74LS00 at U53 Bad 74LS10 at U6	Replace and test. Replace and test. Replace and test.

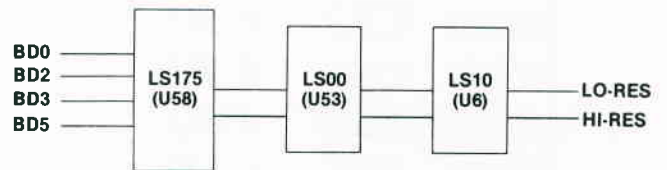
### Troubleshooting Procedure

TURN POWER OFF.  
 DISCONNECT POWER CORD.

(Continued)



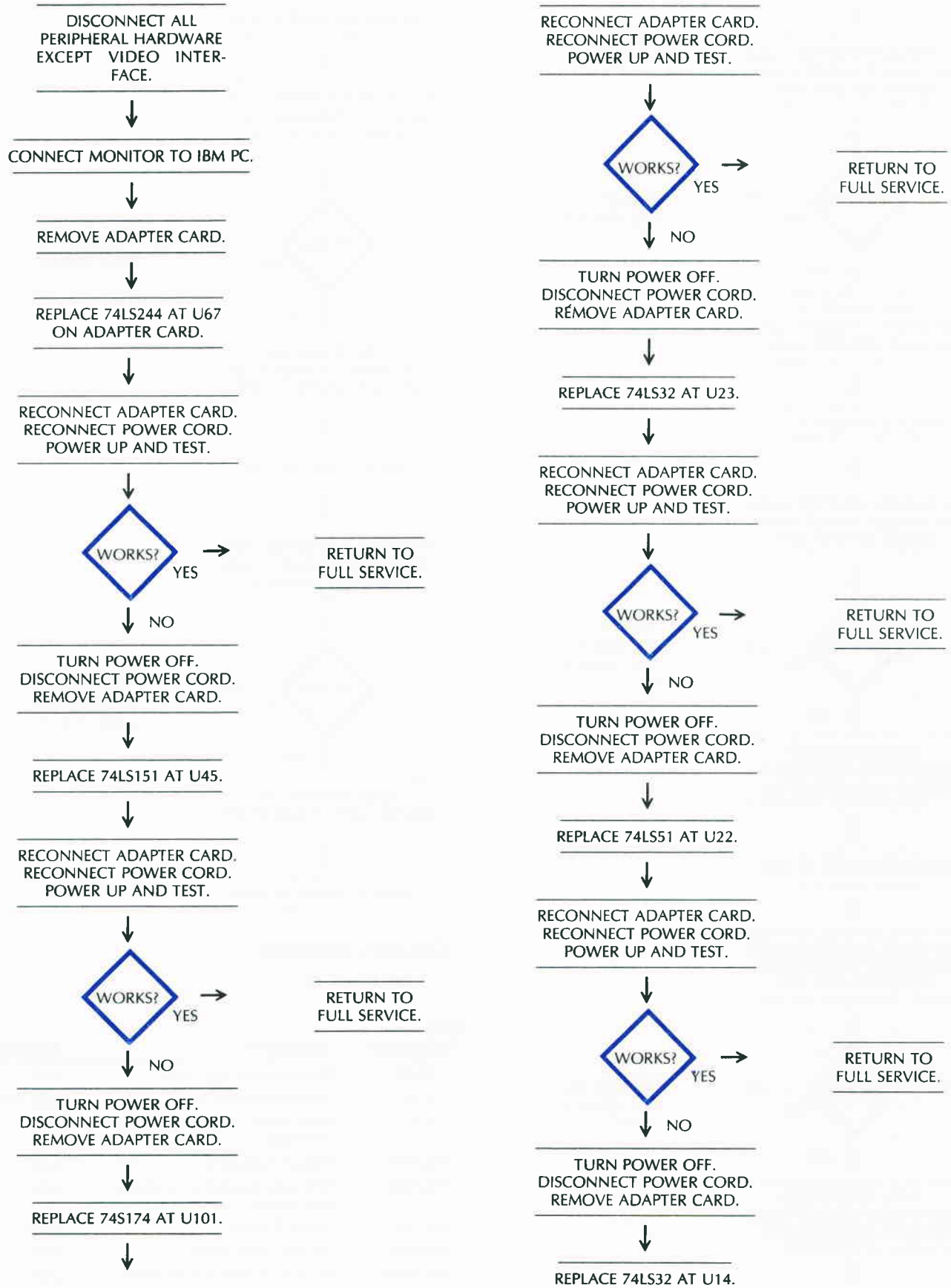
**Circuitry Affected**



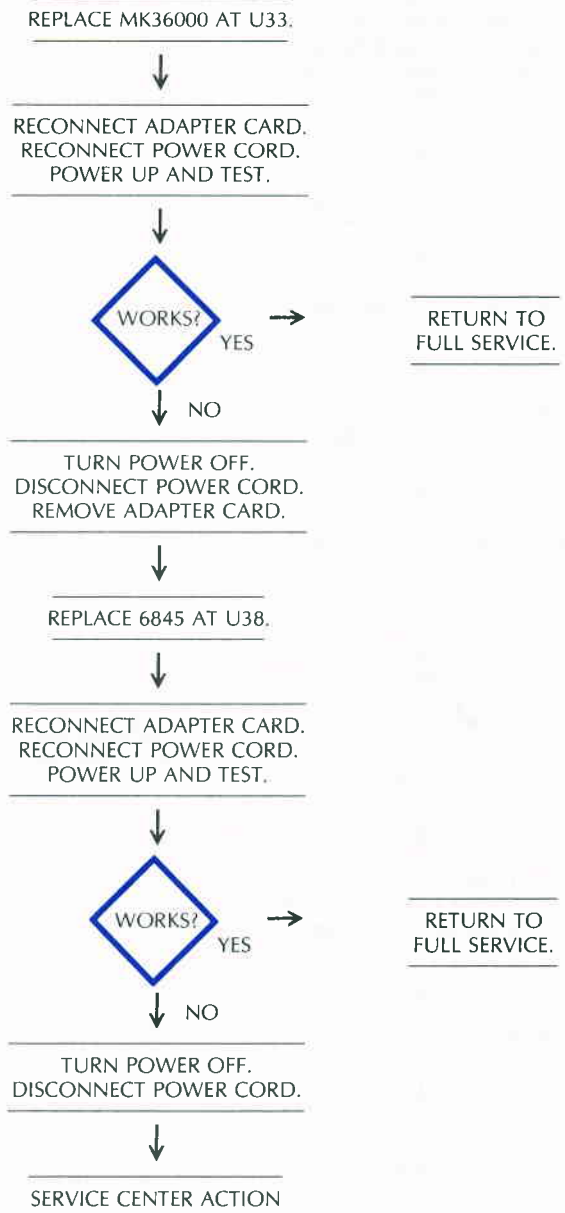
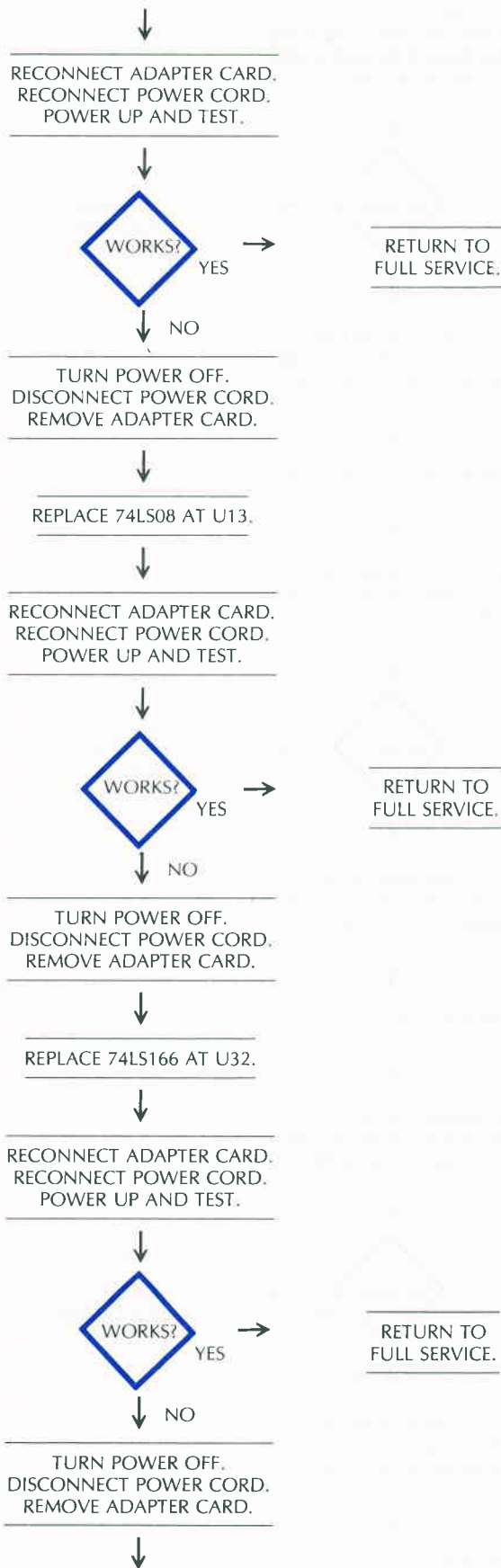
**Fig. 4-25.** Low-resolution graphics circuitry.

Chip designation	Description	Location
74LS00	Quad 2-input NAND gate	U53
74LS10	Triple 3-input NAND gate	U6
74LS175	Quad-D flip-flop	U58





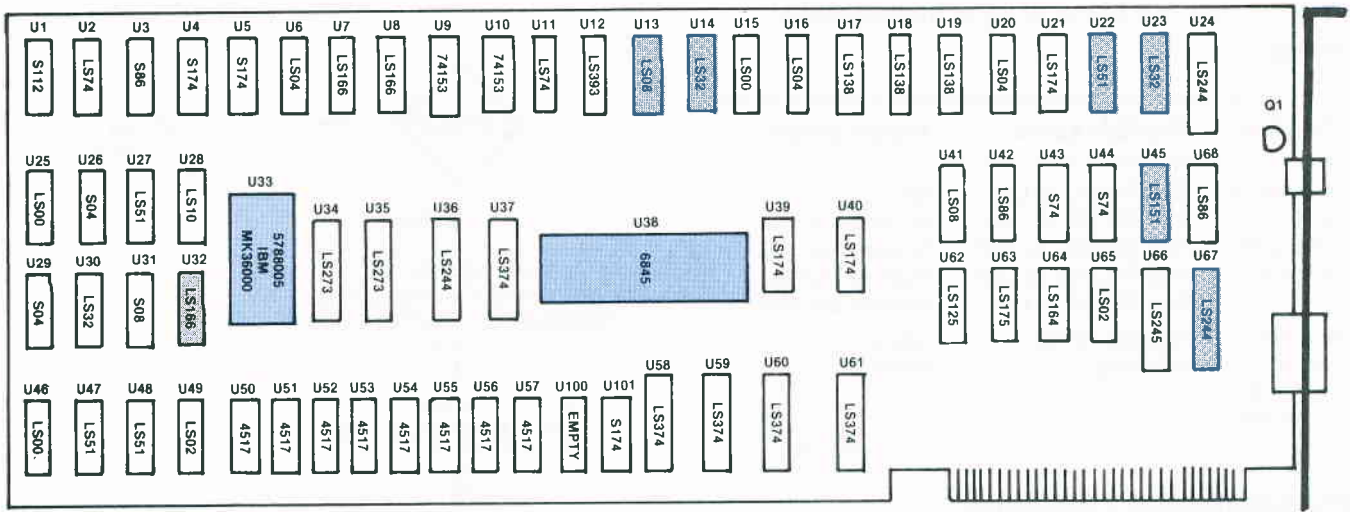
(Continued)



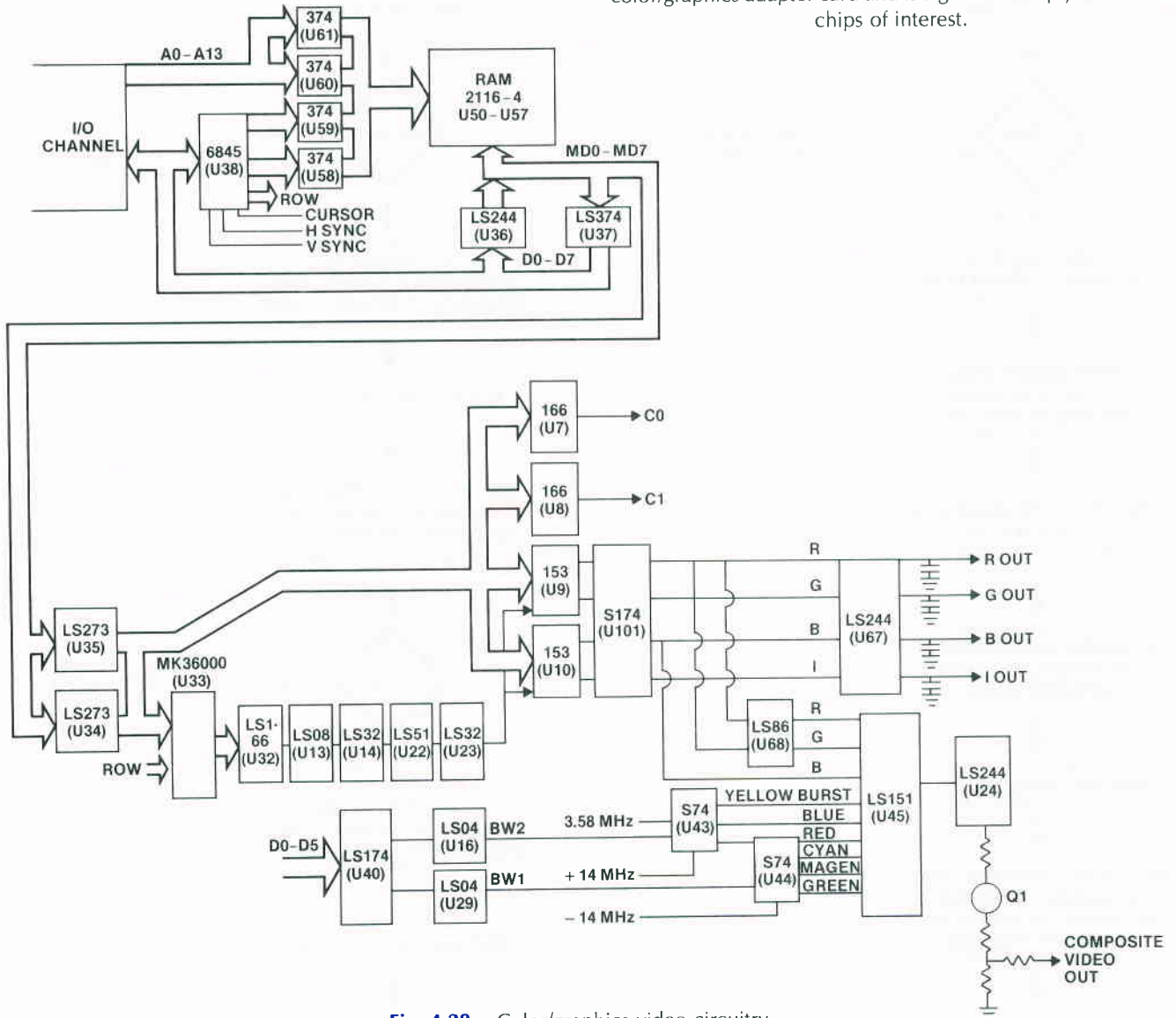
**Circuitry Affected**

See Fig. 4-28.

Chip designation	Description	Location
74LS08	Quad 2-input AND gate	U13
74LS32	Quad 2-input OR gate	U23, U14
74LS51	Dual 2-wide 2-input AND-OR-invert gate	U22
74LS151	8-input multiplexer	U45
74LS166	8-bit serial/parallel-in serial-out shift register	U32
74S174	Hex-D flip-flop	U101
74LS244	Tri-state octal buffer	U67
MK36000	8K × 8-bit NMOS static ROM	U33
6845	CRT controller	U38



**Fig. 4-27.** Chip location guide. This represents the IBM PC color/graphics adapter card and is a guide to help you find the chips of interest.

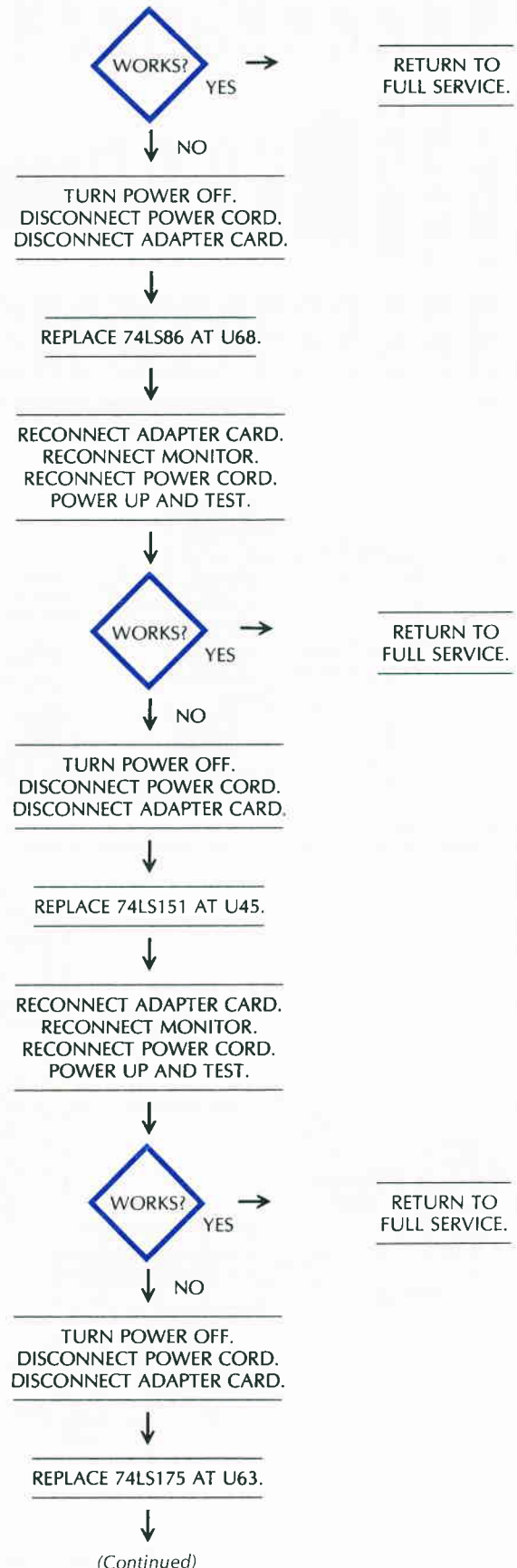
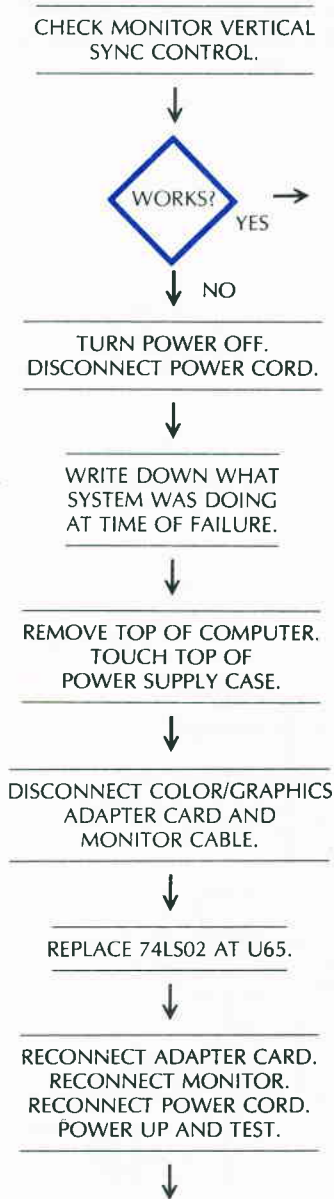


**Fig. 4-28.** Color/graphics video circuitry.

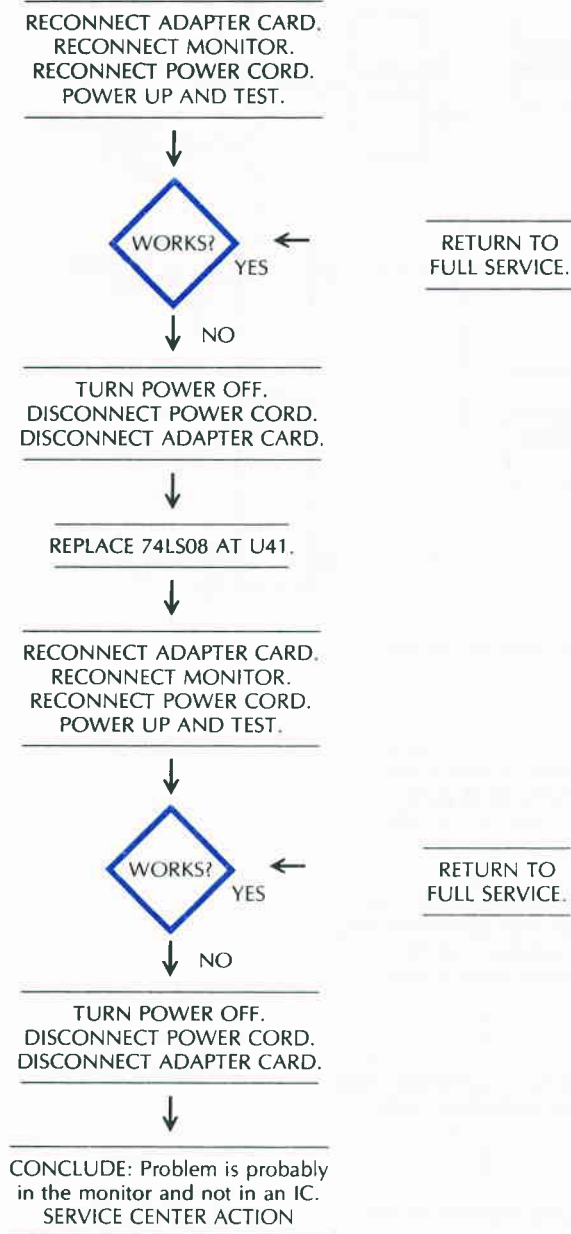
**SYMPTOM: No vertical synchronization (sync)**

Problem	Possible cause	Repair action
No vertical sync getting to monitor	Bad 74LS02 at U65	Replace and test.
	Bad 74LS86 at U68	Replace and test.
	Bad 74LS151 at U45	Replace and test.
	Bad 74LS175 at U63	Replace and test.
	Bad 74LS08 at U41	Replace and test.
Monitor not in sync with computer	Monitor needs adjusting	Adjust monitor controls.

**Troubleshooting Procedure**



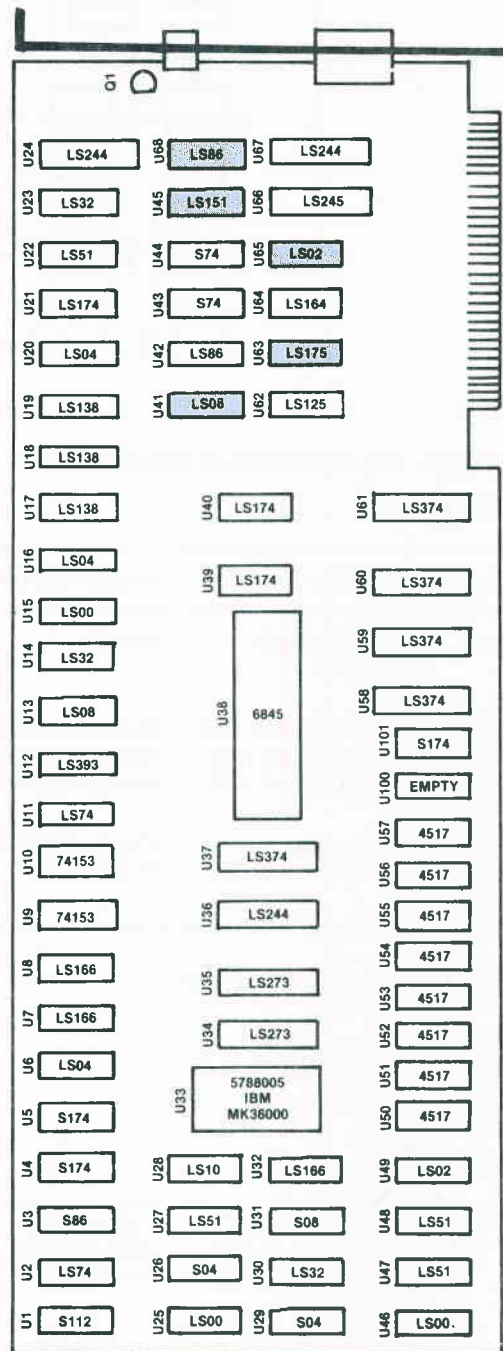
(Continued)



### Circuitry Affected

See Fig. 4-30.

Chip designation	Description	Location
74LS02	Quad 2-input NOR gate	U65
74LS08	Quad 2-input AND gate	U41
74LS86	Quad 2-input EXOR gate	U68
74LS151	8-input multiplexer	U45
74LS175	Quad-D flip-flop	U63



**Fig. 4-29.** Chip location guide. This represents the IBM PC color/graphics adapter and is a guide to help you find the chips of interest.

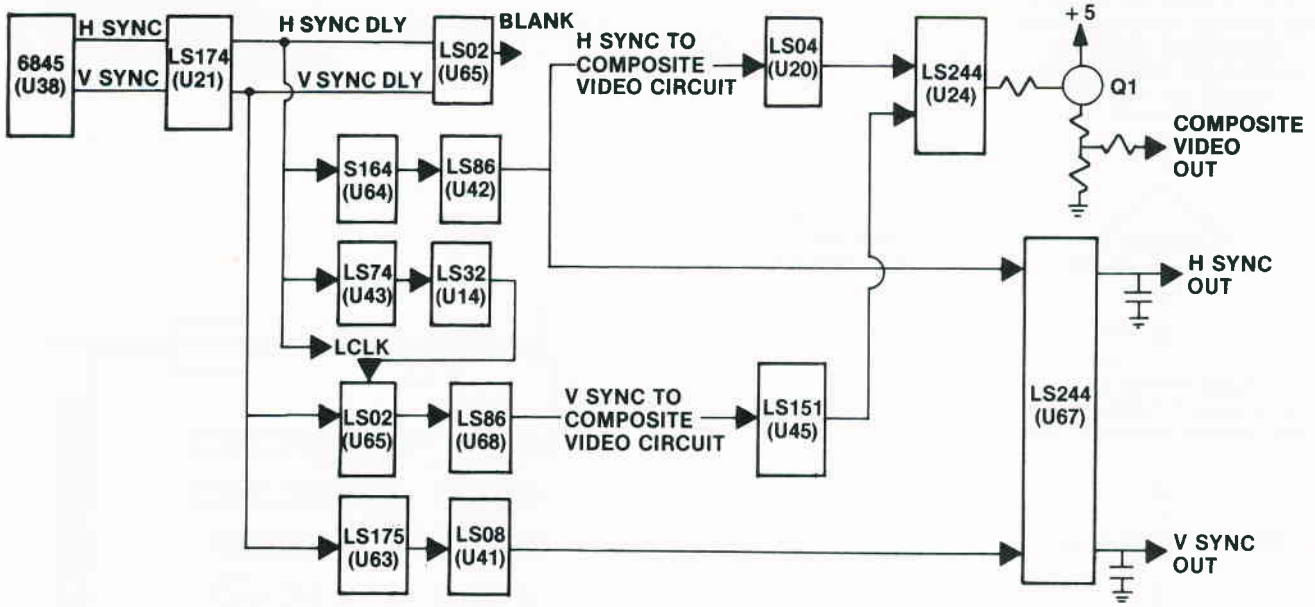


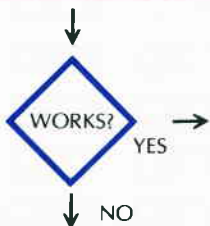
Fig. 4-30. Vertical and horizontal synchronization circuitry.

**SYMPTOM: No horizontal synchronization (sync)**

Problem	Possible cause	Repair action
Monitor not in sync	Monitor needs adjusting	Adjust.
Horizontal sync not being produced	Bad 74LS164 at U64 Bad 74LS86 at U42 Bad 74LS04 at U20	Replace and test. Replace and test. Replace and test.
Monitor not functioning	Bad monitor	Check and replace if necessary.

**Troubleshooting Procedure**

CHECK MONITOR HORIZONTAL SYNC CONTROL.



TURN POWER OFF. DISCONNECT POWER CORD.

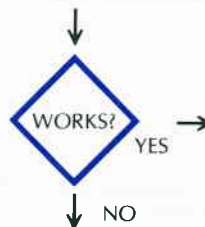
WRITE DOWN WHAT SYSTEM WAS DOING AT TIME OF FAILURE.

REMOVE TOP OF COMPUTER. TOUCH TOP OF POWER SUPPLY CASE.

DISCONNECT ADAPTER CARD AND MONITOR CABLE

REPLACE 74LS164 AT U64.

RECONNECT ADAPTER CARD. RECONNECT MONITOR. RECONNECT POWER CORD. POWER UP AND TEST.



TURN POWER OFF. DISCONNECT POWER CORD. DISCONNECT ADAPTER CARD.

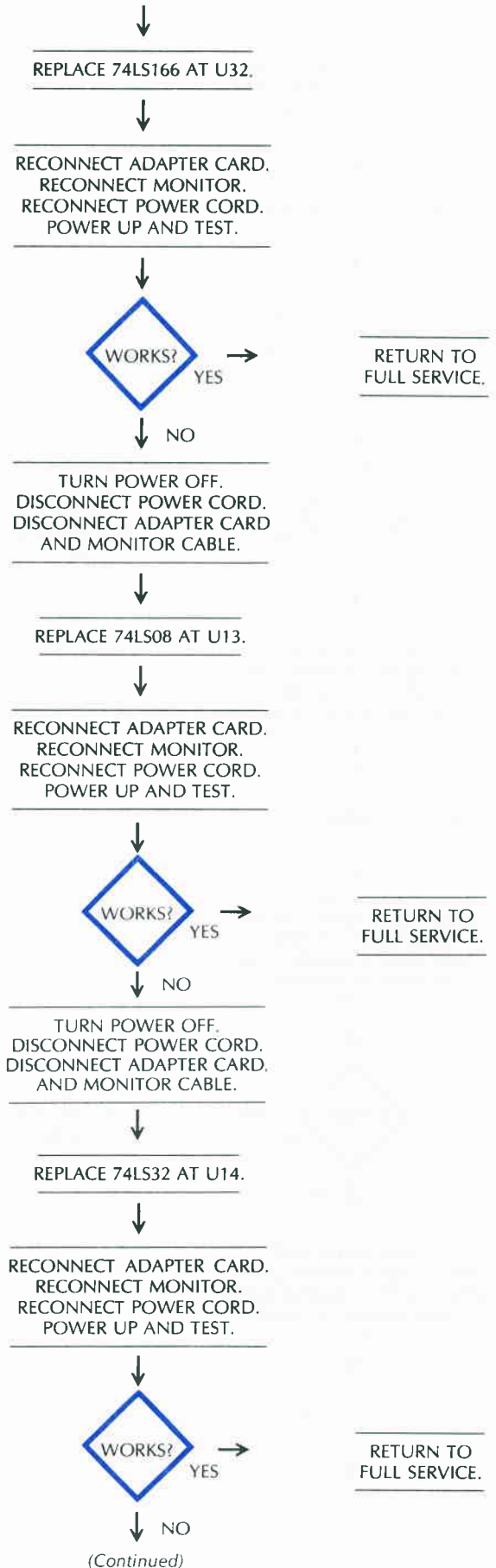
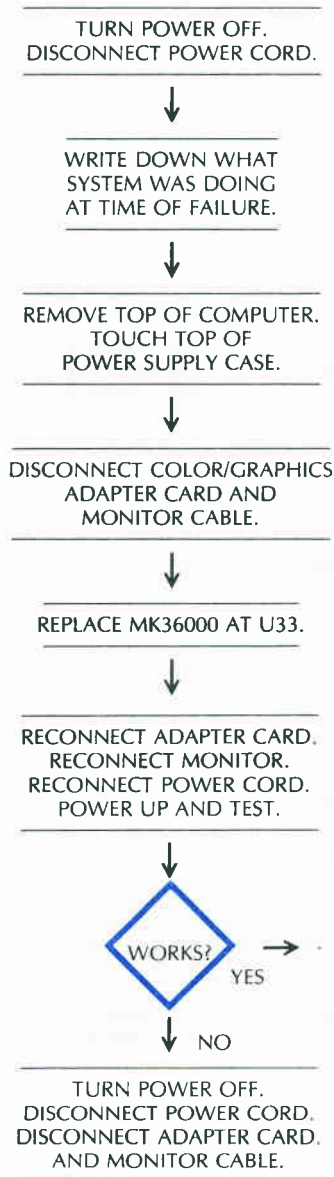
(Continued)





Problem	Possible cause	Repair action
Data not staying in RAM correctly	Bad RAM chip somewhere between U50 and U57	Replace and test.
Characters not generated properly	Bad MK36000 at U33	Replace and test.
	Bad 74LS166 at U32	Replace and test.
	Bad 74LS08 at U13	Replace and test.
	Bad 74LS32 at U14	Replace and test.
	Bad 74LS51 at U22	Replace and test.
	Bad 74LS32 at U23	Replace and test.
	Bad 74153 at U9	Replace and test.
	Bad 74153 at U10	Replace and test.
	Bad 74S174 at U101	Replace and test.

### Troubleshooting Procedure



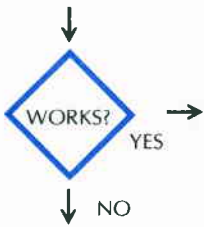
TURN POWER OFF.  
DISCONNECT POWER CORD.  
DISCONNECT ADAPTER CARD  
AND MONITOR CABLE.



REPLACE 74LS51 AT U22.



RECONNECT POWER CORD.  
RECONNECT ADAPTER CARD.  
RECONNECT MONITOR.  
POWER UP AND TEST.



RETURN TO  
FULL SERVICE.

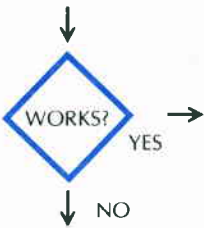
\*TURN POWER OFF.  
DISCONNECT POWER CORD.  
DISCONNECT ADAPTER CARD  
AND MONITOR CABLE.



REPLACE 74LS32 AT U23.



RECONNECT ADAPTER CARD.  
RECONNECT MONITOR.  
RECONNECT POWER CORD.  
POWER UP AND TEST.



RETURN TO  
FULL SERVICE.

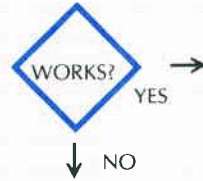
TURN POWER OFF.  
DISCONNECT POWER CORD.  
DISCONNECT ADAPTER CARD  
AND MONITOR CABLE.



REPLACE 74LS273 AT U35.



RECONNECT ADAPTER CARD.  
RECONNECT MONITOR.  
RECONNECT POWER CORD.  
POWER UP AND TEST.



RETURN TO  
FULL SERVICE.

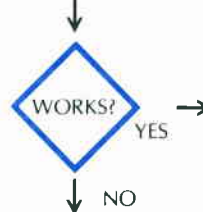
TURN POWER OFF.  
DISCONNECT POWER CORD.  
DISCONNECT ADAPTER CARD  
AND MONITOR CABLE.



REPLACE 74LS273 AT U34.



RECONNECT ADAPTER CARD.  
RECONNECT MONITOR.  
RECONNECT POWER CORD.  
POWER UP AND TEST.



RETURN TO  
FULL SERVICE.

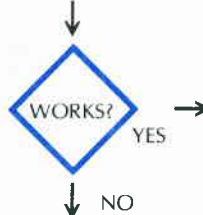
TURN POWER OFF.  
DISCONNECT POWER CORD.  
DISCONNECT ADAPTER CARD  
AND MONITOR CABLE.



REPLACE 74153 AT U9.

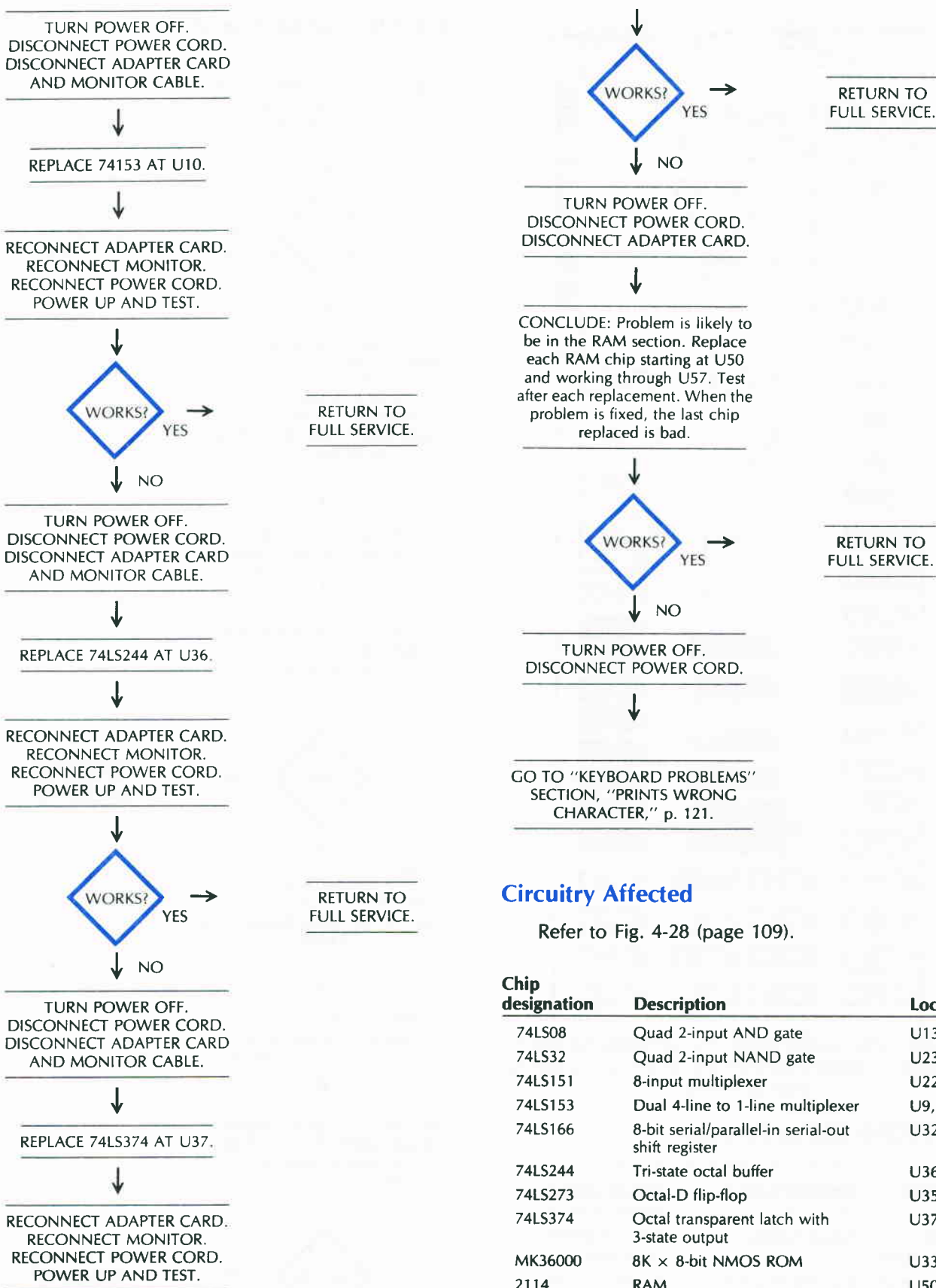


RECONNECT ADAPTER CARD.  
RECONNECT MONITOR.  
RECONNECT POWER CORD.  
POWER UP AND TEST.



RETURN TO  
FULL SERVICE.

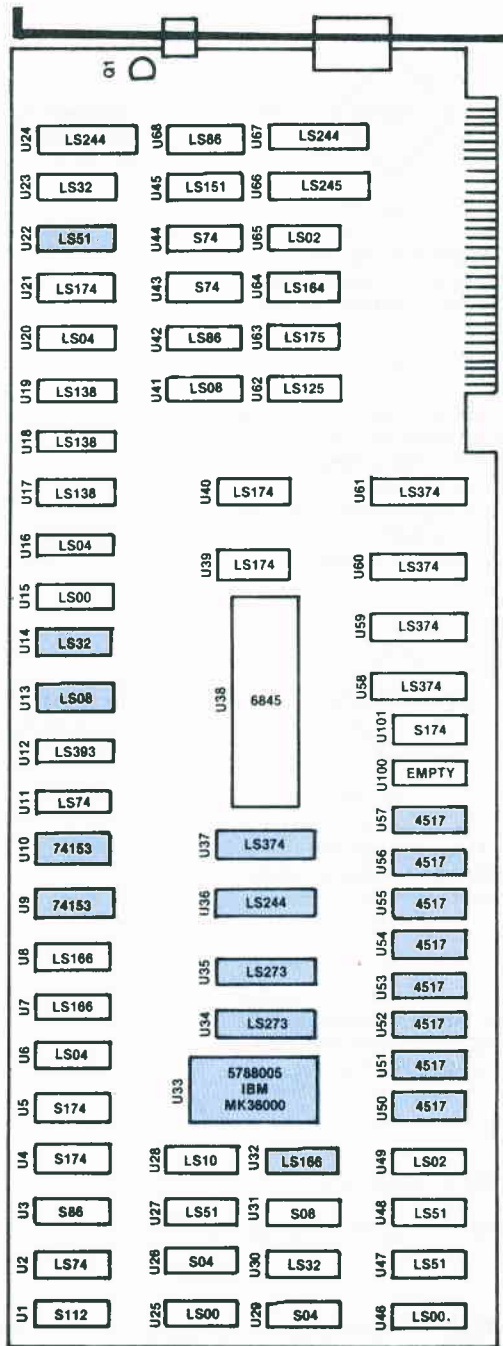
(Continued)



### Circuitry Affected

Refer to Fig. 4-28 (page 109).

Chip designation	Description	Location
74LS08	Quad 2-input AND gate	U13
74LS32	Quad 2-input NAND gate	U23, U14
74LS151	8-input multiplexer	U22
74LS153	Dual 4-line to 1-line multiplexer	U9, U10
74LS166	8-bit serial/parallel-in serial-out shift register	U32
74LS244	Tri-state octal buffer	U36
74LS273	Octal-D flip-flop	U35, U34
74LS374	Octal transparent latch with 3-state output	U37
MK36000	8K × 8-bit NMOS ROM	U33
2114	RAM	U50–U57

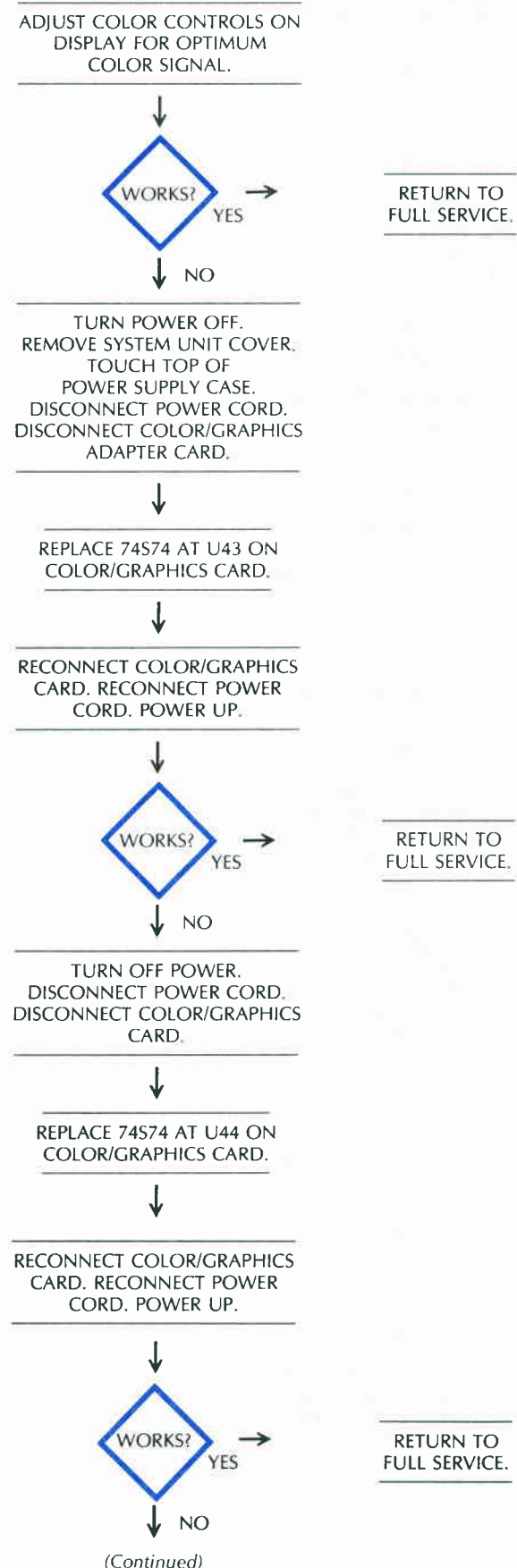


**Fig. 4-33.** Chip location guide. This represents the IBM PC color/graphics adapter card and is a guide to help you find the chips of interest.

**SYMPTOM: Bad or no color**

Problem	Possible cause	Repair action
Monitor misadjusted	Adjust monitor	Adjust monitor color controls.
Color signal improper	Bad 74S74 at U43	Replace and test.
	Bad 74S74 at U44	Replace and test.
	Bad 74S174 at U101	Replace and test.
	Bad 74LS151 at U45	Replace and test.
	Bad 74LS244 at U67	Replace and test.

**Troubleshooting Procedure**



(Continued)



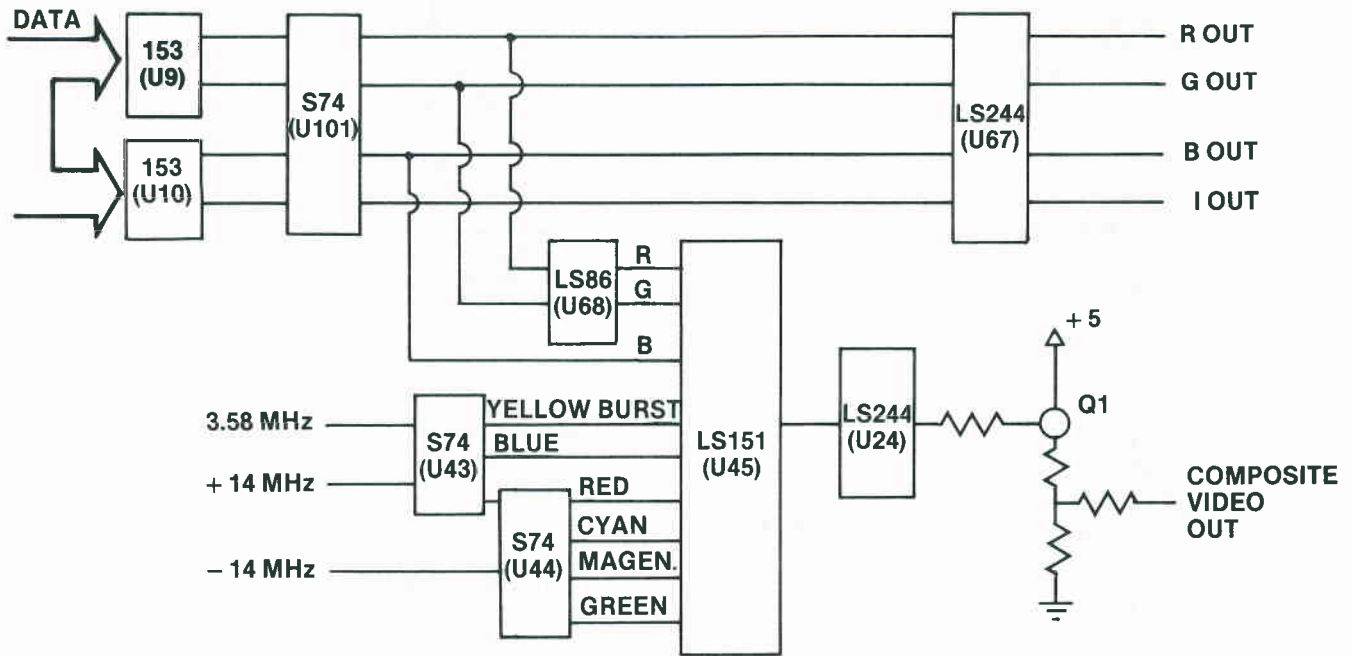


Fig. 4-35. Circuitry for "bad or no color" problem.

Chip designation	Description	Location
74S74	Dual-D flip-flop	U43, U44
74LS151	8-input multiplexer	U45
74S174	Hex-D flip-flop	U101
74LS244	Tri-state octal buffer	U67

**SYMPTOM: No hi-res text, lo-res text, or no graphics**

Problem	Possible cause	Repair action
No lo-res text selected or produced	Bad 74LS174 at U40 Bad 74LS04 at U16	Replace and test. Replace and test.

**Troubleshooting Procedure**

TURN POWER OFF.  
REMOVE SYSTEM UNIT COVER.  
TOUCH TOP OF POWER SUPPLY CASE.  
DISCONNECT POWER CORD.  
DISCONNECT ADAPTER CARD.

REPLACE 74LS174 AT U40 ON COLOR/GRAPHICS CARD.

RECONNECT COLOR/GRAPHICS CARD. RECONNECT POWER CORD. POWER UP.



RETURN TO FULL SERVICE.

TURN OFF POWER.  
DISCONNECT POWER CORD.  
DISCONNECT COLOR/GRAPHICS CARD.

REPLACE 74LS04 AT U16 ON COLOR/GRAPHICS CARD.

RECONNECT COLOR/GRAPHICS CARD. RECONNECT POWER CORD. POWER UP.

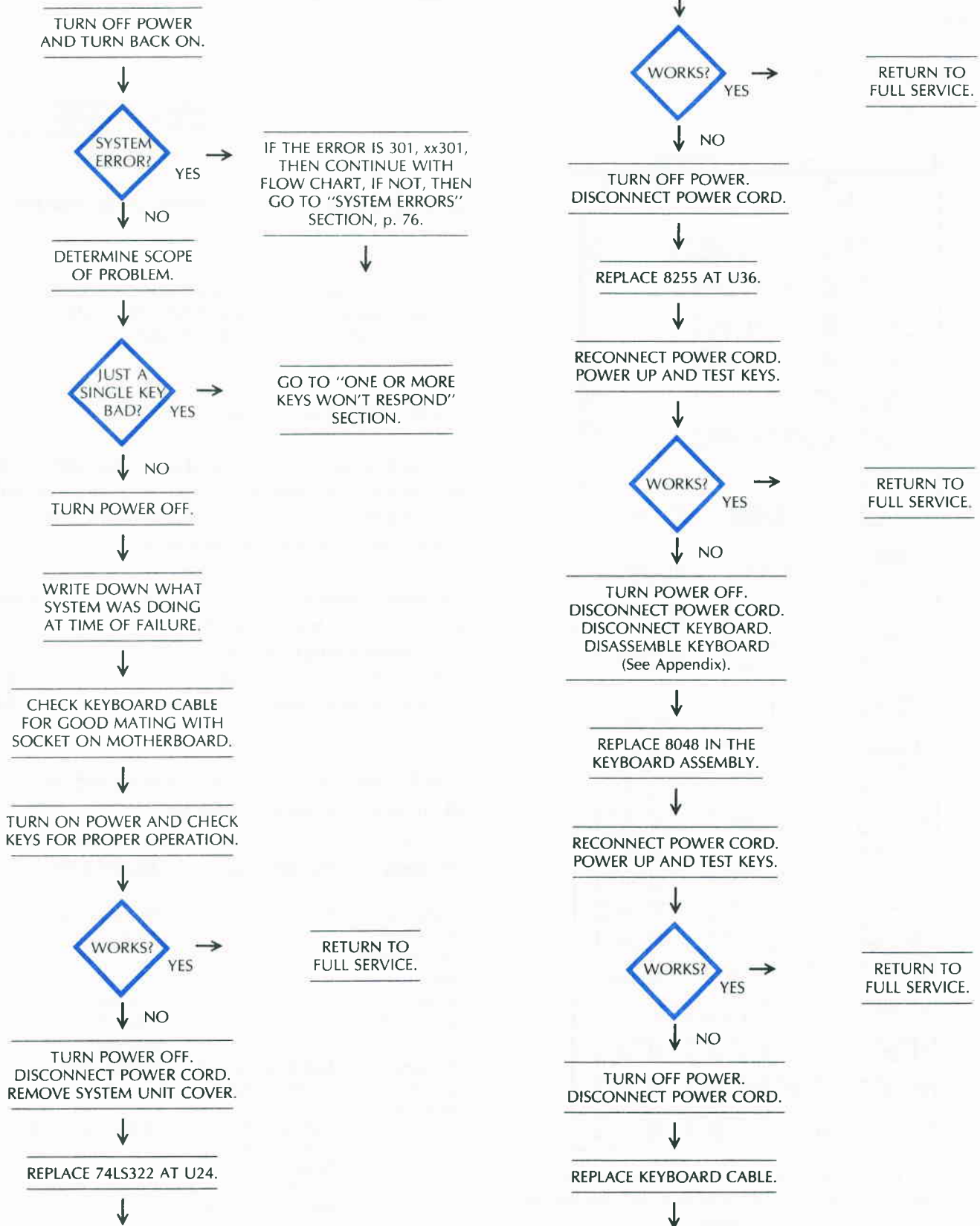


RETURN TO FULL SERVICE.

(Continued)



### Troubleshooting Procedure



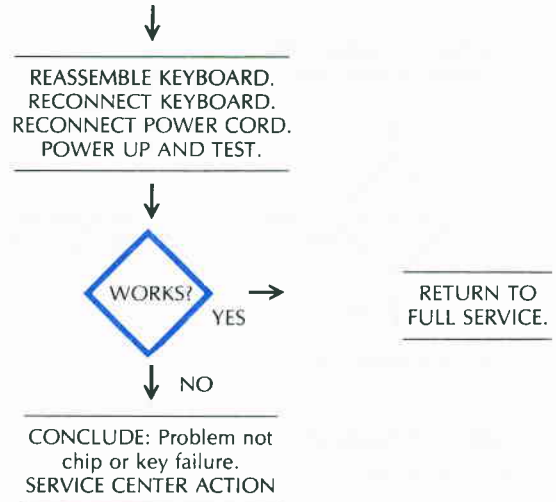
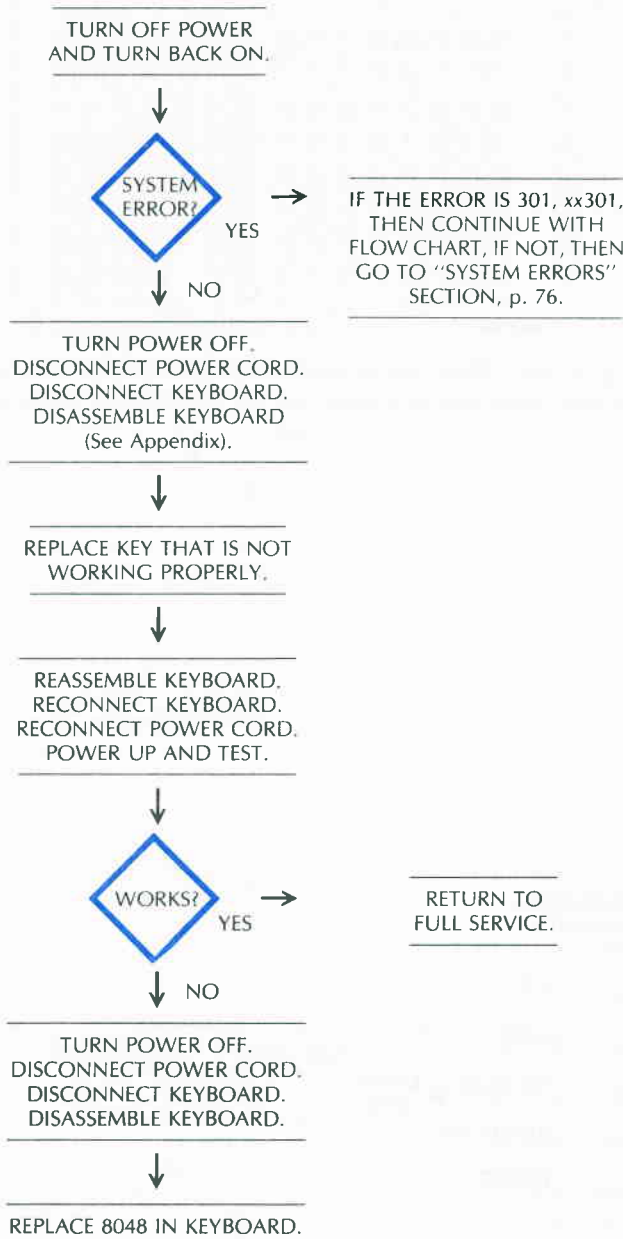
(Continued)



**SYMPTOM: One or more keys won't work**

Problem	Possible cause	Repair action
Key not making proper contact	Bad key	Replace key.
Keyboard signal not proper	Bad 8048 in keyboard	Replace and test.

**Troubleshooting Procedure**



**Circuitry Affected**

Refer to Fig. 4-39.

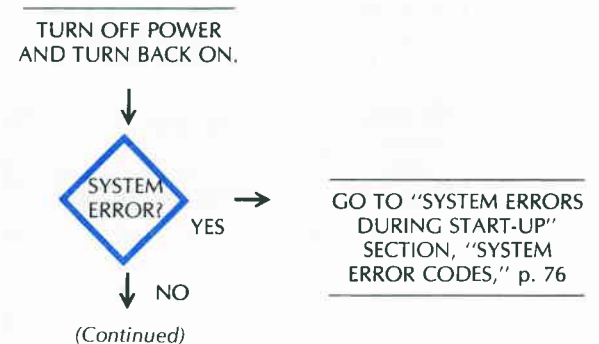
Chip designation	Description	Location
8048	Single chip, 8-bit microcomputer	In keyboard

For chip location guide, refer to Fig. 4-38A.

**SYMPTOM: Keyboard stays in upper or lower case**

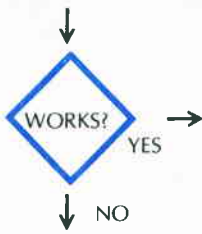
Problem	Possible cause	Repair action
Key stuck	Sticky key	Dry key with hairdryer.
Key not making proper contact	Bad Caps Lock key	Replace key.
Keyboard signal not proper	Bad 8048 in keyboard	Replace and test.

**Troubleshooting Procedure**



(Continued)

USING A HAIRDRYER, RUN HOT AIR OVER KEY THEN TEST AGAIN.

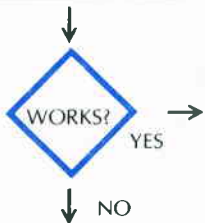


RETURN TO FULL SERVICE.

TURN POWER OFF. DISCONNECT POWER CORD. DISCONNECT KEYBOARD. DISASSEMBLE KEYBOARD. (SEE APPENDIX).

REPLACE CAPS LOCK KEY.

REASSEMBLE KEYBOARD. RECONNECT KEYBOARD. RECONNECT POWER CORD. POWER UP AND TEST.

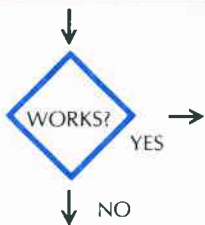


RETURN TO FULL SERVICE.

TURN POWER OFF. DISCONNECT POWER CORD. DISCONNECT KEYBOARD. DISASSEMBLE KEYBOARD.

REPLACE 8048 IN KEYBOARD.

REASSEMBLE KEYBOARD. RECONNECT KEYBOARD. RECONNECT POWER CORD. POWER UP AND TEST.



RETURN TO FULL SERVICE.

CONCLUDE: Problem not chip or key failure. SERVICE CENTER ACTION

### Circuitry Affected

Refer to Fig. 4-39.

Chip designation	Description	Location
8048	Single chip, 8-bit microcomputer	In keyboard

For chip location guide, refer to Fig. 4-38A.

### OTHER I/O PROBLEMS

This section treats the most common input/output problems.

Symptom Category	Page
Speaker won't work properly	125
Light pen won't work properly	128
Cassette won't load data	130
Can't write data to cassette	132

#### SYMPTOM: Speaker won't work properly

Problem	Possible cause	Repair action
Speaker cone won't respond	Bad speaker	Replace speaker.
No signal from circuitry to speaker	Speaker wires disconnected Bad 75477 at U95 Bad 74LS38 at U63 Bad 8255 at U36 Bad 8253 at U34	Reconnect wires. Replace and test. Replace and test. Replace and test. Replace and test.

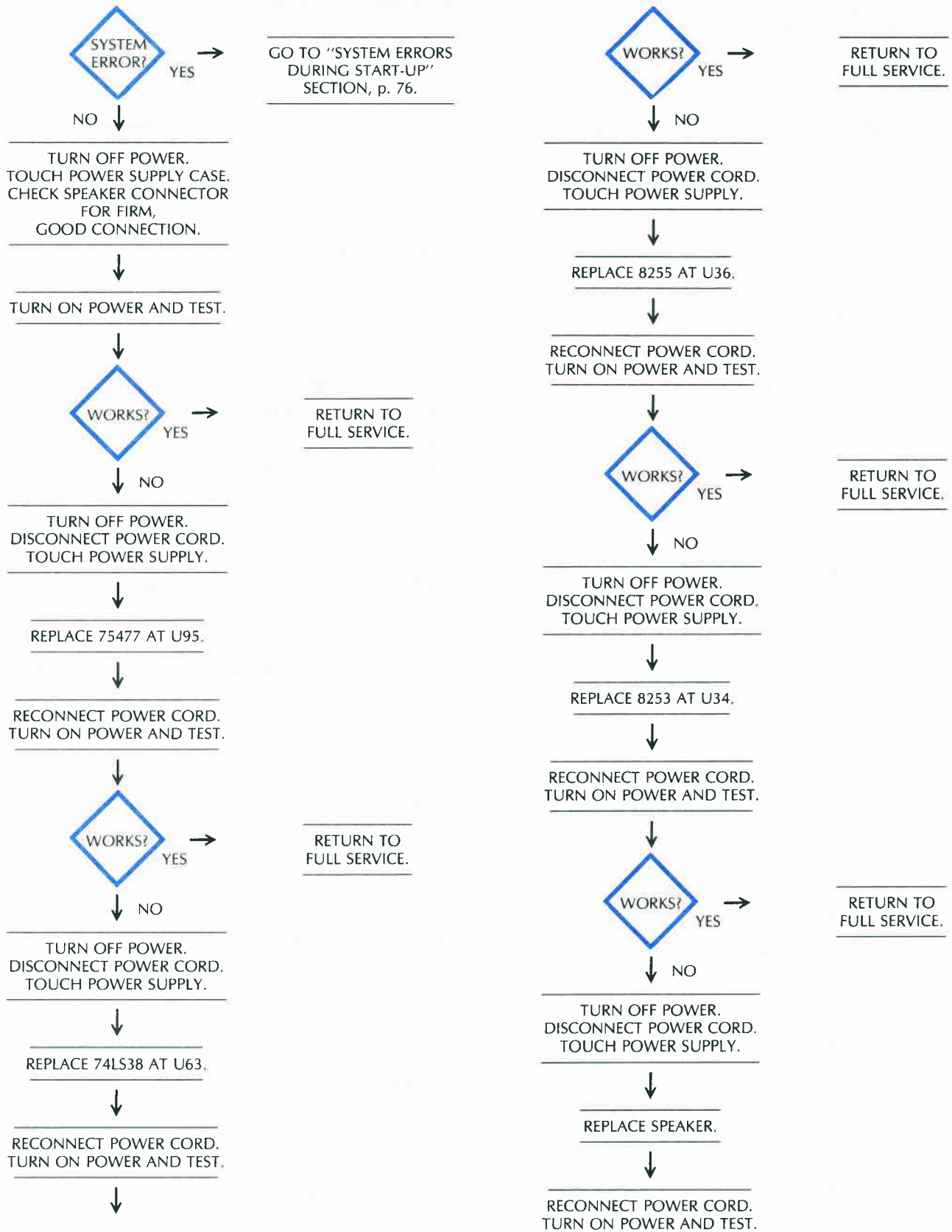
#### Troubleshooting Procedure

TURN POWER OFF.

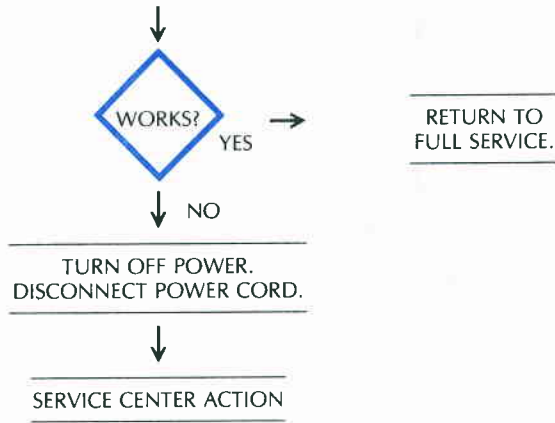
REMOVE SYSTEM UNIT COVER. TOUCH TOP OF POWER SUPPLY CASE.

TURN ON POWER.

(Continued)



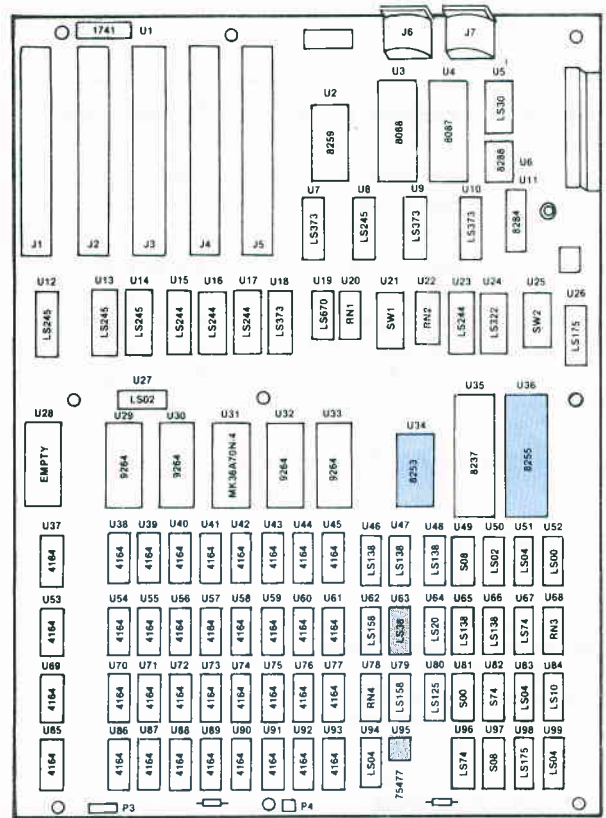
(Continued)



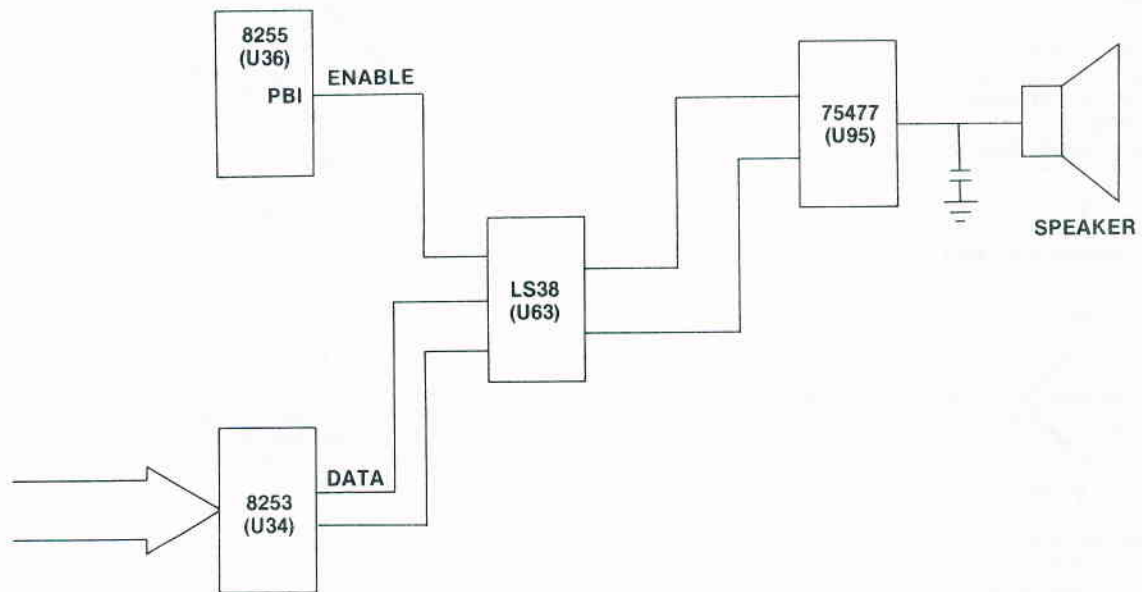
**Circuitry Affected**

See Fig. 4-40.

Chip designation	Description	Location
8253	Programmable interval timer	U34
8255	Programmable peripheral interface	U36
75477	Dual peripheral NAND driver	U95
74LS38	Quad 2-input NAND buffer	U63



**Fig. 4-41.** Location guide. This represents the IBM PC system board and is a guide to help you find the components of interest.

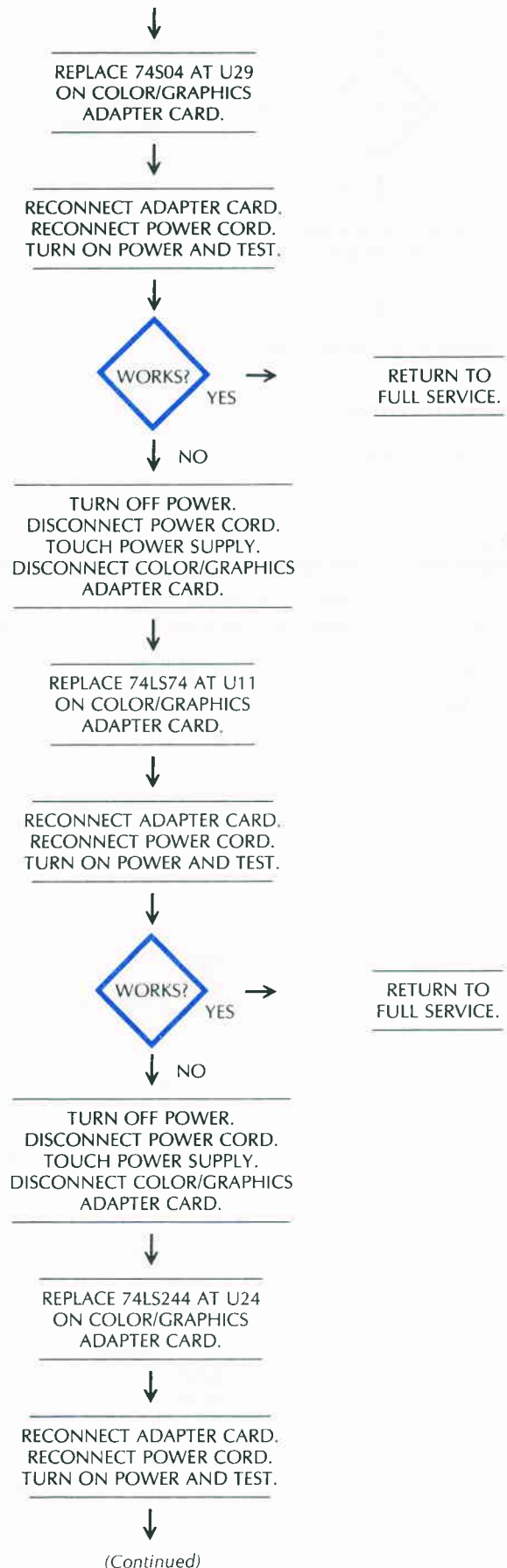
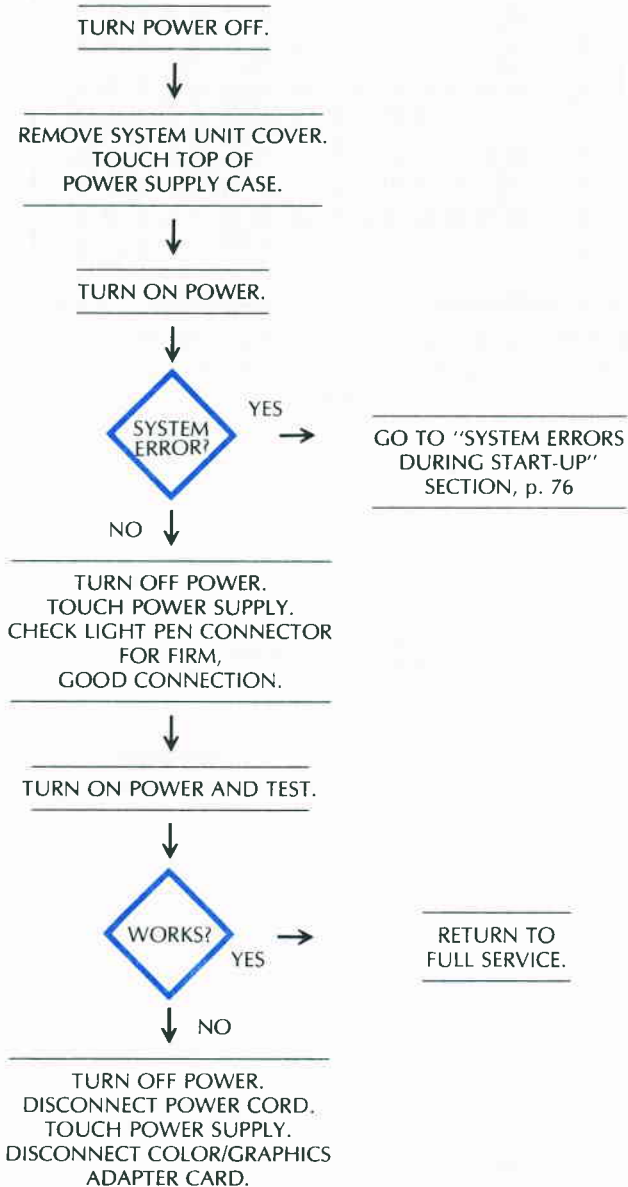


**Fig. 4-40.** Speaker output circuitry.

**SYMPTOM: Light pen won't work properly**

Problem	Possible cause	Repair action
Light pen won't respond	Bad light pen Bad or loose connector	Replace pen. Check connector.
No signal from circuitry to data bus	Bad 74S04 at U29	Replace and test.
	Bad 74LS74 at U11	Replace and test.
	Bad 74LS244 at U24	Replace and test.
	Bad 74LS138 at U18 Bad 74LS138 at U17	Replace and test. Replace and test.

**Troubleshooting Procedure**



(Continued)



### Circuitry Affected

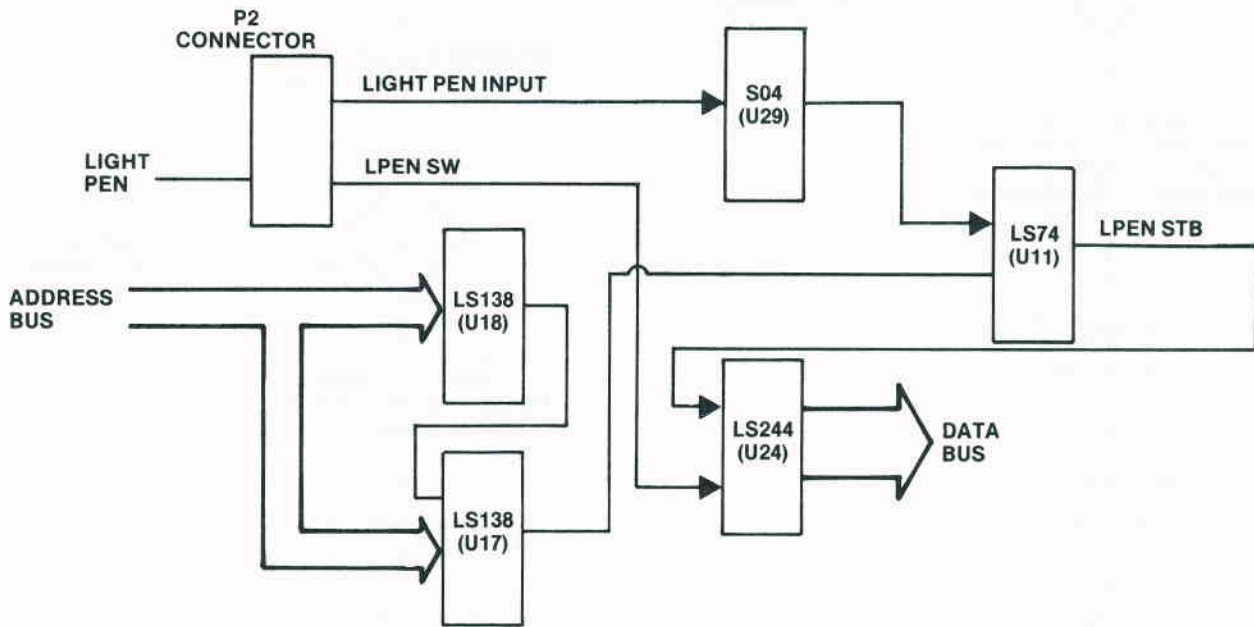


Fig. 4-43. Light pen circuitry.

Chip designation	Description	Location
74S04	Hex inverter	U29
74LS74	Dual-D flip-flop	U11
74LS138	1/8 decoder/demultiplexer	U17, U18
74LS244	Tri-state octal buffer	U24

### SYMPTOM: Cassette won't load data

Problem	Possible cause	Repair action
Signal not coming in from cable	Bad cable	Replace cable.
	Volume not set properly	Adjust tape recorder volume.
	No signal on tape	Replace bad tape.
Signal not getting to data bus.	Bad 1741 at U1	Replace and test.
	Bad 74LS38 at U63	Replace and test.
	Bad 8255 at U36	Replace and test.

### Troubleshooting Procedure

TURN OFF POWER AND TURN ON AGAIN.



YES →

GO TO "SYSTEM ERRORS DURING START-UP" SECTION, p. 76

NO ↓

CHECK CABLE CONNECTIONS.



TRY KNOWN GOOD TAPE.



YES →

RETURN TO FULL SERVICE.

NO ↓

TURN POWER OFF. DISCONNECT POWER CORD.



REMOVE SYSTEM UNIT COVER. TOUCH TOP OF POWER SUPPLY CASE.



(Continued)

DISCONNECT ALL PERIPHERAL  
HARDWARE EXCEPT VIDEO  
ADAPTER CARD  
AND CASSETTE.

REPLACE 1741 AT U1.

RECONNECT POWER CORD.  
POWER UP AND TEST.



RETURN TO  
FULL SERVICE.

TURN POWER OFF.  
DISCONNECT POWER CORD.

REPLACE 74LS38 AT U63.

RECONNECT POWER CORD.  
POWER UP AND TEST.



RETURN TO  
FULL SERVICE.

TURN POWER OFF.  
DISCONNECT POWER CORD.

REPLACE 8255 AT U36.

RECONNECT POWER CORD.  
POWER UP AND TEST.



RETURN TO  
FULL SERVICE.

CONCLUDE: Problem is not  
caused by chip failure.  
SERVICE CENTER ACTION

**Circuitry Affected**

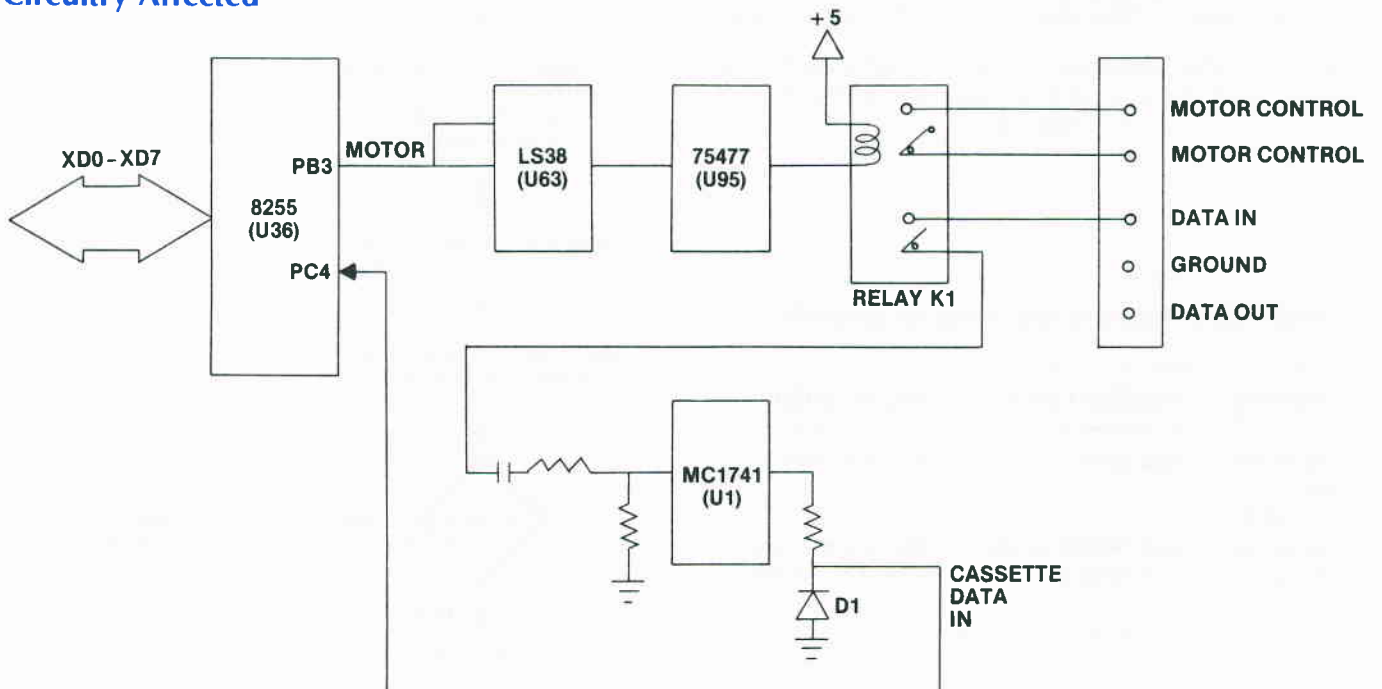


Fig. 4-44. Cassette data input circuitry.

Chip designation	Description	Location
1741	Operational amplifier	U1
74LS38	Quad 2-input NAND gate	U63
8255	Programmable peripheral interface	U36

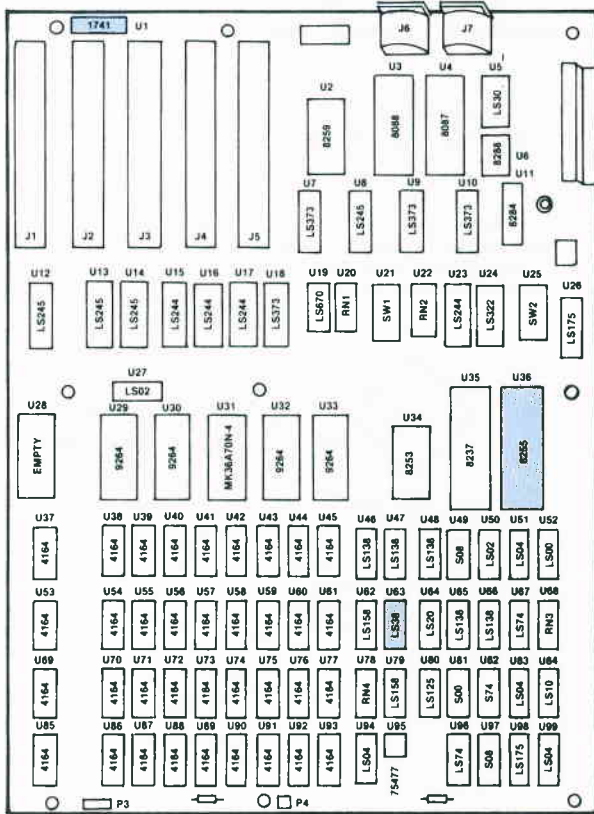
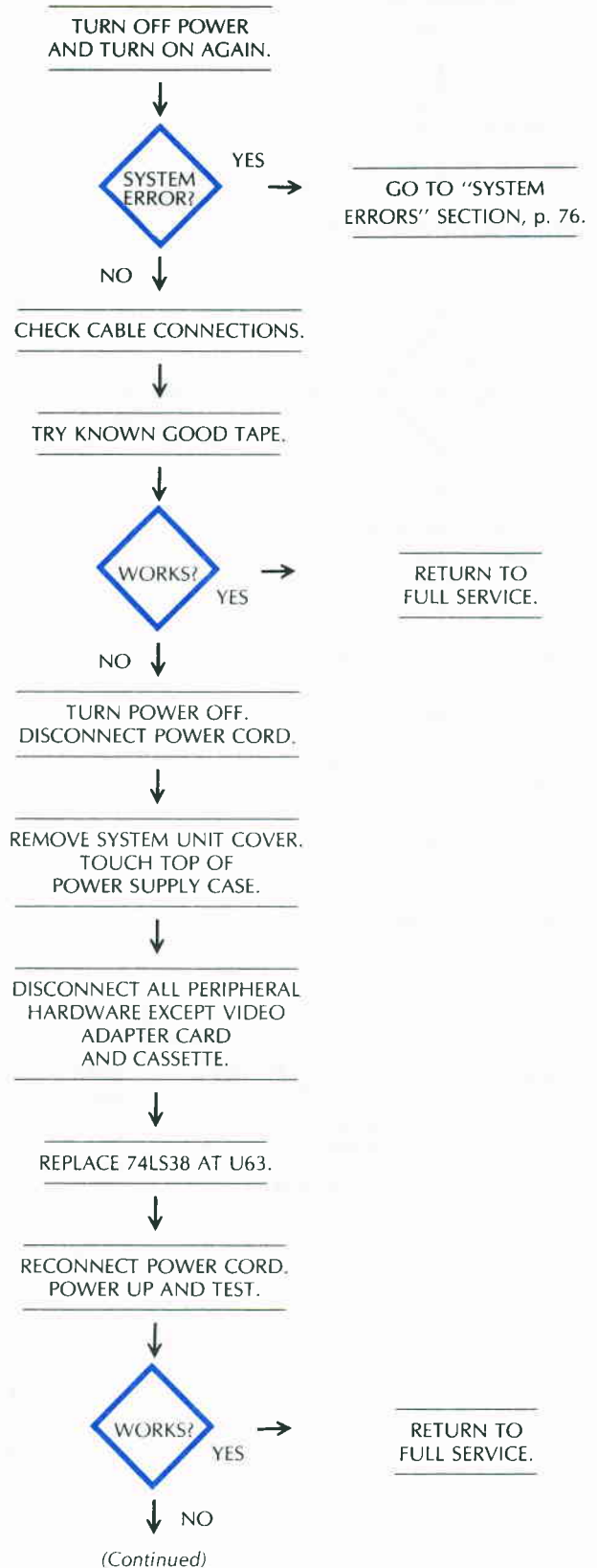


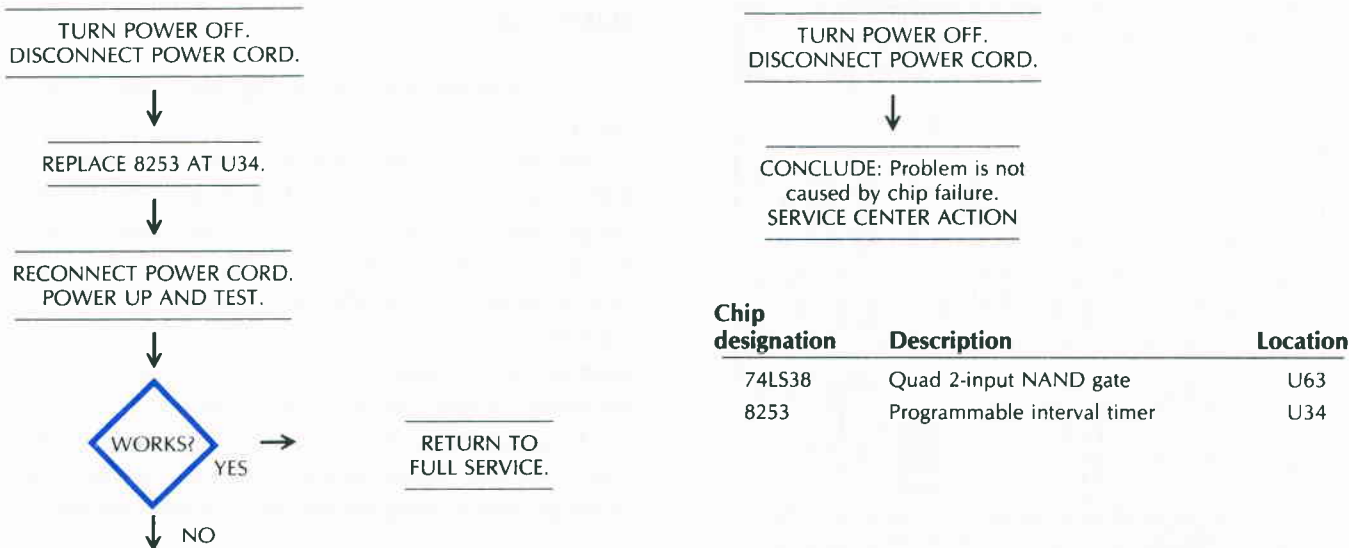
Fig. 4-45. Chip location guide. This represents the IBM PC system board and is a guide to help you find the chips of interest.

**SYMPTOM: Can't write data to cassette**

Problem	Possible cause	Repair action
Signal not going out the cable	Bad cable	Replace cable.
Signal not being sent to tape.	Bad 74LS38 at U63 Bad 8253 at U34	Replace and test. Replace and test.

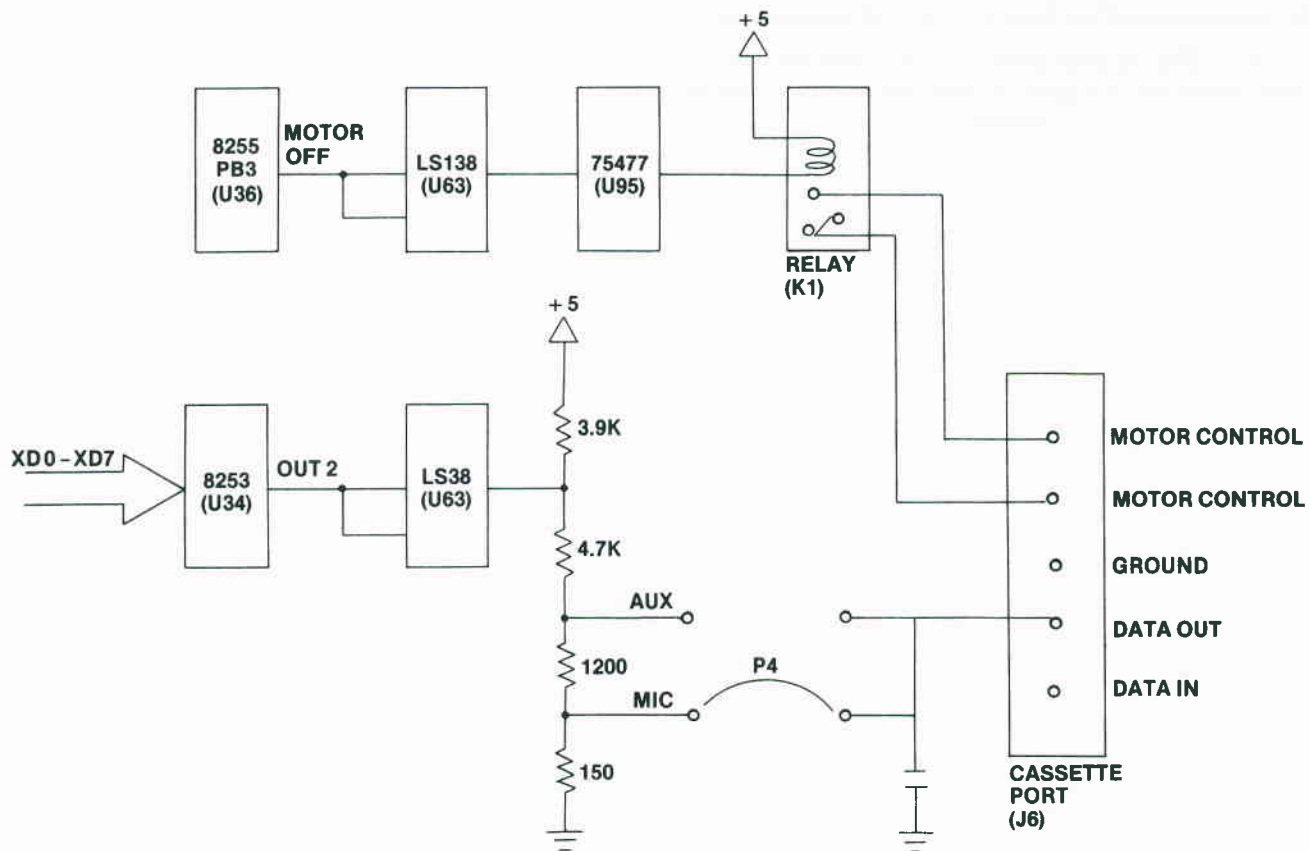
**Troubleshooting Procedure**





Chip designation	Description	Location
74LS38	Quad 2-input NAND gate	U63
8253	Programmable interval timer	U34

**Circuitry Affected**



**Fig. 4-46.** Cassette data output circuitry.

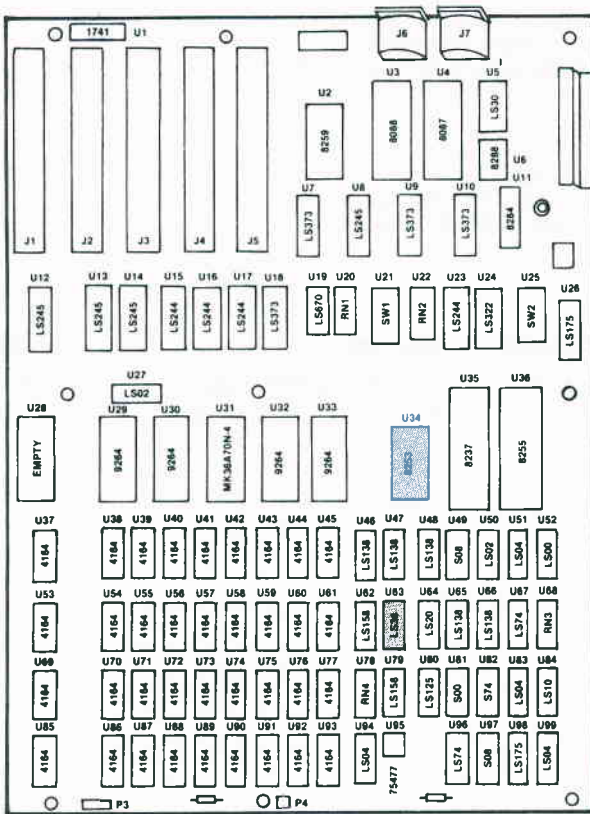


Fig. 4-47. Chip location guide. This represents the IBM PC system board and is a guide to help you find the chips of interest.

## SUMMARY

This detailed troubleshooting and repair chapter has covered most of the general problems experienced by owners (and repairers) of computer systems. If following one of the guides in this chapter doesn't solve the problem, you can take the final step (Service Center Action) yourself if you feel qualified. Chapter 6 will provide assistance if you decide to really dig into your machine.

**Caution:** Only experienced technicians should work on power supply and monitor problems.

Remember that the information in Chapter 5, "Routine Preventive Maintenance," can help prevent many of the problems analyzed for repair in this chapter.

# Routine Preventive Maintenance

---

*In Chapter 4 you went through a step-by-step guide for detailed troubleshooting and corrective maintenance of the IBM Personal Computer. Chapter 5 discusses another type of maintenance, one that is intended not to fix a problem but rather to prevent a problem from ever happening. Preventive maintenance is in every way as important as corrective maintenance. In this chapter you'll learn what factors damage your computer and cause it to fail and what you can do to prevent these failures.*

Often, the price you pay to buy your computer system is actually only a small part of the overall system cost. The life-cycle cost of the equipment can be much larger than the initial purchase investment. This total cost increases dramatically as the costs for software, books, magazine subscriptions, extra interface boards, disks, and service center repair charges are added in. Service costs can grow to 10 to 50 percent of your system cost.

Occasionally a repair expense can exceed the value of the equipment that is broken. It's when we look at high repair costs that terms like "mean time between failures" (MTBF) and "mean time to repair" (MTTR) become important. While your IBM PC has an excellent reliability track record, the way you operate your machine and the environment in which you place

it become important to the MTBF number. Another factor to consider is that those "bargain" interfaces and peripherals that you bought at such a low cost probably have a less than excellent reliability record. You get what you pay for.

Your IBM computer is sturdy and fast, and it performs work easily and accurately. Under most operating conditions, PCs are indeed very reliable machines. But, like other machines, they wear out and fail.

As your experience with computers grows and the computer becomes more and more essential in your home and business, your need for uninterrupted computer power increases. If you have to take your computer to a repair shop, you can expect your machine to be gone for 1 to 3 weeks, although many problems can be fixed within a day.

Most large companies take steps to protect their huge computer and data processing investment. Accidents and unnecessary failures cost thousands of dollars in lost business. A small business, with a single microcomputer, two disk drives, and a printer, faces just as catastrophic a loss by system failure; yet most small businesses don't take steps to prevent such failures.

Computers don't burn out. They wear out or are forced out by human error or adverse operating condi-

tions. If you misuse your computer or don't protect it from the environmental elements, you can be the cause for its failure.

A few moments of care can result in many more hours of good, consistent performance. We call this care *preventive maintenance*, or just PM. Just as you periodically check the oil and water in your car's engine, lubricate the car, and wash and wax the body, so you should care for and protect your computer.

Futurists today feel that there are three major kinds of items each of us will purchase in our lifetime—a house, a car, and now a computer. Each is a major investment. Each deserves to receive good care. You can get good, reliable operation from your computer for many months, if not years, if you provide timely and proper maintenance to keep the system in peak condition.

## CONTRIBUTORS TO SYSTEM FAILURE

Proper PM begins with an understanding of what we are fighting. Six factors that can influence the performance of your personal computer (not including the disk-eating dog or the floppy-bending baby) are:

- Excessive temperature
- Dust build-up
- Noise interference
- Power-line problems
- Corrosion
- Magnetic fields

Each acts to cause computer breakdown. This chapter tells how to successfully battle these enemies of reliable performance.

## HEAT

As you learned earlier, the chips and other devices in your computer are sensitive to high temperatures. During normal operation, your PC generates heat that is generally tolerable to the circuitry. Usually, leaving your IBM PC on for long periods won't hurt it, because the slots and air vents let enough of the heat dissipate to the outside of the case. The rest of the warm air is drawn into the power supply by its built-in fan and exhausted out the rear of the chassis.

As long as the components on the system board are not too hot to touch, the amount of heat being pro-

duced should not cause any damage. However, heat can become a problem when you begin adding adapter interface boards. The power supply has plenty of voltage margin and is protected against overload, but with an increased power demand it produces more heat. The design of the PC case, with the motherboard lying flat, provides an open space for hot air to rise, but the air has a tendency to hang over the board rather than moving out the vents. Adding adapter boards that connect to the motherboard, or peripheral connectors that plug into the rear of the computer, further restricts any natural convection or fan suction. This causes the components to get even warmer. The power supply heats up more as it pumps out more current to power the piggyback boards or peripherals that derive power from the computer. The piggyback boards, the power supply, and the motherboard all give off heat, and the inside temperatures soar.

Excessive heat within a component causes premature aging and failure. The heat produced during operation is not uniform across the device, but peaks at specific locations on the chip (generally at the input/output connectors where the leads meet the chip itself). The usual effects of heating and cooling are to break down the contacts or junctions in the chip or other device, causing open-circuit failure. When hot, these devices can produce intermittent "soft errors," with loss of or incorrect data. This effect is known as "thermal wipeout," and it's a chronic problem in loaded systems that aren't sufficiently cooled. The continual heating and cooling action during normal operation also causes the socketed chips to work themselves out of their sockets.

Heat can also contribute to disk failure. Disks, those inexpensive yet extremely valuable platters, act just the way your stereo records do when exposed to heat, especially the heat of the sun. If you leave your disks setting in a hot car, you can be sure some warpage will occur. If the thin disk warps too much, you will lose whatever information you stored on that floppy. You could try to set it flat in the sun and hope to "warp" it back into shape, but the success rate for this "repair" isn't very high.

## Countering the Effects of Heat

The following actions should help in preventing heat-related failures:

- Reseat the socketed chips if intermittent failures occur.
- Keep the cooling vents clear.

- Keep your system dust free inside and outside.
- Do your PMs (preventive maintenance actions) regularly.
- Keep disks in a cool, dry location.
- Install an external cooling fan if system operation becomes intermittent when the system heats up.

Many IBM PC users find the AIP PCool fan a worthwhile investment when five cards or a piggyback memory card have been installed. This fan mounts just behind the PC faceplate.

While more and more users struggle with the internal heat problem, a quiet revolution is occurring in fan technology. Brushless DC (direct current) fans are being designed with thermal sensor interfaces that can monitor the PC's system unit temperature and cause fan speed to change relative to the amount of heat sensed. These "smart" fans are also much quieter than the relatively noisy AC (alternating current) fans currently in use. As each new computer is born, another potential application for a DC fan appears. These thermal-sensing fans can yield more efficient, less costly, and longer-operating computer systems.

## COLD

The effect of cold on computers is an interesting subject. The U.S. government is currently working on superfast computers that operate in supercold environments. Electronic components operate quite well in cold temperatures, but mechanical components have trouble functioning when the temperature drops. For example, the operating range for a standard floppy disk drive is approximately 40°F to 115°F. At the low end, mechanical sluggishness occurs increasing the possibility of erratic data storage and retrieval. The floppy disk itself can become brittle when it gets cold.

### Countering the Effects of Cold

The rule of thumb for cold temperatures is to let the system warm up to room temperature (stabilize) before turning on the power. If the temperature is comfortable for you, it's fine for the system.

## DUST AND OTHER PARTICLES

Just like flies at a picnic, dust particles descend on computer equipment. Interestingly, the dust is

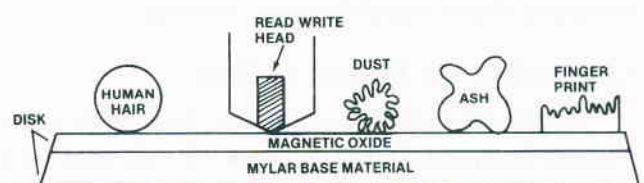
attracted to the display monitor in the same way it is to a television screen. If the dust is not cleaned from the screen, it will build up, and eventually someone will rub it and mar the screen surface.

The static electric charge that builds up in the computer and the display monitor attracts dust and dirt. That's why large computer systems are kept in cool, clean computer rooms. They require special air conditioning and dust-free spaces, because the large equipment generates more heat and is just as susceptible to failures caused by dust build-up.

Dust and dirt build-up insulate the circuit devices and prevent the release of the heat generated during normal operation. If the devices can't dissipate this heat, the inside temperature rises higher than normal, causing the chips and other components to wear out even faster. Dust is a major contributor to memory chip failure. It seems to be attracted to heat. Have you ever noticed that dust builds up on light bulbs in your lamps or on the tops of stereos and televisions more than it does on cooler objects? The dust particles are charged and therefore are attracted to the magnetic field around electrical equipment.

Mechanical devices such as printers and disk drives fail more often than solid-state electronic devices because mechanical and electromechanical devices have moving parts that get dirty easily, causing overheating and earlier failure. Look inside your printer and you'll see the kinds of dirt and dust that are collecting. Paper sheds tiny particles as it moves through the printer. These particles become insulators to prevent the heat generated during normal operation from escaping off the equipment and into the air.

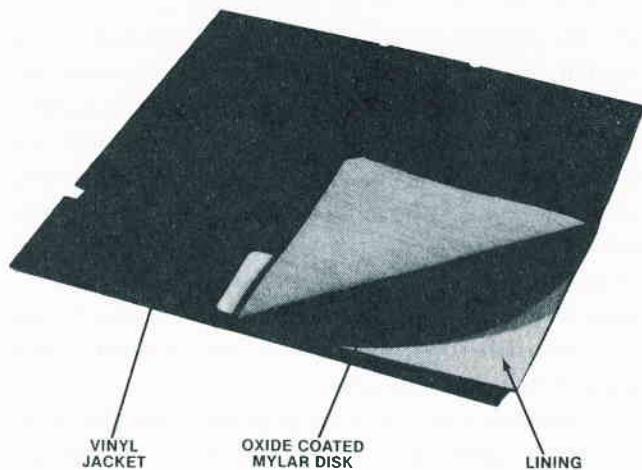
Disk drives have more dust-related problems than printers because they are designed with read/write heads that operate on or slightly above the diskette. The space between the head and the disk is small. When the head rides on the disk surface, dust and dirt can cause major problems. Foreign particles such as dirt, smoke, ash, and tiny fibers can also cause catastrophic problems in diskette jackets and in disk drives themselves (see Fig. 5-1).



**Fig. 5-1.** With a read head that rides on the surface of the disk, any small piece of foreign material can cause problems.

The air we breathe is full of airborne particles, but most of these are too small even to be seen, let alone become a problem. The larger particles in the air cause computer system problems. Cigarette ash, for example, can settle on a disk surface and move from track to track inside the disk jacket, causing loss of data.

Inside the vinyl jacket surrounding each of your disks is a special lining that traps dirt and dust as the disk spins in the drive (Fig. 5-2). This doesn't mean you



**Fig. 5-2.** A floppy disk, showing the vinyl jacket, jacket lining, and oxide-coated mylar disk.

can get careless about dust and dirt. Dirt on a disk can be swept off by the drive read/write head and gouge out a path on the disk surface, or it can stick on the head and cause other disks to be gouged. The dirt can also cause the head itself to corrode and wear out.

Smoke from cigarettes and cigars can coat the internal surfaces of the disk drive with a gummy soot that can not only produce data transfer errors, but also interfere with the mechanical operation, further increasing the wear on the drive. Smoke is also believed to cause rapid oxidation on pins and connectors, increasing the likelihood of intermittent errors. Most computer centers and computer rooms are off-limits for smoking.

### Countering the Effects of Dust

Dust build-up can be controlled. Thoroughly cleaning your computer area every week will help keep your system in top condition. Dirt and dust can be removed from the equipment housings using a cloth slightly dampened with a mild soap solution. Clean electrical

equipment with the power turned off. Be careful you don't wet or moisten the electronic components.

After washing the surface, rewipe the outside of the equipment with a soft cloth dampened with a mixture of one part liquid fabric softener to three parts water. The chemical make-up of some liquid softeners is almost the same as that of antistatic chemical spray. The chemicals in this inexpensive solution last longer than some antistatic sprays and help make your screens less susceptible to scratching. Wiping the case and screen with one of these liquids helps to keep static charges from attracting dust to the screen and tops of the hardware.

Another quite successful technique is blowing dust away from the screen with a pressurized can of anti-static dusting spray, as shown in Fig. 5-3. Using this kind of product means you don't have to wipe your equipment off first. Wiping a screen should be done carefully, because you could scratch the screen if some hard dust or dirt particles are on the screen or your cloth.



**Fig. 5-3.** An antistatic spray for computer equipment. (Falcon Safety Products, Inc., Mountainside, New Jersey)

The following are some manufacturer-recommended screen and cabinet cleaning methods:

- Use one part fabric softener to three parts water to clean your screen.
- Use mild soap and water; use a soft cloth for drying.
- Use a window cleaner spray.

**(Note:** Although the monitor literature from several manufacturers recommends this, be careful. Common household aerosol sprays, solvents, polishes, or cleaning agents may damage your monitor cabinet and screen. The safest cleaning solution is mild soap and water.)

- Use an antistatic spray.

Associated with cleaning advice, each manufacturer also included an important safety precaution:

**Caution:** Make sure the power is off and the plug(s) pulled out of the power socket(s). Use a damp cloth. Don't let any liquid run or get into your equipment.

You can use a long plastic nozzle on the end of your vacuum hose to reach in and around everything inside the hardware. Dust and small particles can be cleaned off the circuit board inside your PC using a soft brush. Fig. 5-4 shows a hand tool to assist in vacuuming out electronic equipment. Be careful not to damage any of the parts. Brush lightly.



**Fig. 5-4.** A handy tool for cleaning dust off keyboards and circuit components. (Mini-Vac, Inc., Glendale, California)

Another control measure is the use of dust covers. You may not have an air-conditioned, air-purified room in which to use your IBM PC, so dust covers become of paramount importance. Plastic covers, made static-free with an antistatic aerosol or by wiping the surface with the fabric softener-water mixture, will provide good dust protection for your system.

Here is a summary of ways to counter dust in your IBM computer system.

- Use dust covers.
- Keep windows closed.
- No smoking near your IBM PC system.
- No crumb-producing foods near your computer.
- No liquids on any equipment.
- Don't touch the surface of any floppy disk.
- Vacuum the system and the area weekly.
- Clean your monitor screen with static-reducing material.

## NOISE INTERFERENCE

Your computer and its peripherals are sensitive to interference noise, which can affect the proper operation or transfer of information. But what is noise, and where does it come from? How can you get rid of it?

Noise can be described as those unexpected or undesired random changes in voltage, current, data, or sound. Noise is sometimes called *static*. It can be a sudden pulse of energy, a continuous hum in the speaker, or a garbled display of characters.

Three types of noise cause problems: acoustic noise that affects you, the user, noise that affects your computer system, and noise that affects other electronic equipment. *Acoustic noise* includes, for example, the crying of a baby, the blare of an overpowered stereo, and the loud, consistent tap-tapping of a computer printer. Noise that affects the computer and other equipment can be radiated, conducted, or received. It takes the form of *electromagnetic radiation* (EMR). EMR noise can be further classified as low- or high-frequency radiation. Noise can be categorized as shown in Fig. 5-5. If the noise occurs in the 1 hertz to 10K hertz range, it is called *electromagnetic interference* (EMI). If it occurs at a frequency above 10 kHz, it is called *radio frequency interference* (RFI). RFI can occur in two forms: *conducted RFI* and *radiated RFI*.

If the RFI is fed back from the PC through the power cord to the high-voltage AC power line, it is classified as conducted RFI. In this case, the power line acts as an antenna, transmitting the noise interference out. When your computer system and its cabling transmit noise, the noise source is called radiated RFI.

EMI has three primary components:

- Transient EMI
- Internal EMI
- Electrostatic discharge (ESD)

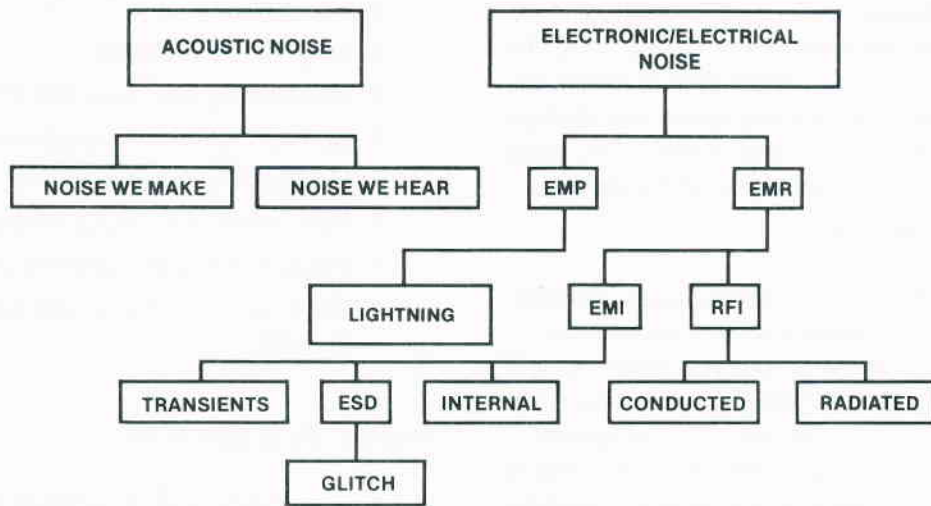


Fig. 5-5. The various forms of noise that affect computer equipment.

**Transient EMI** includes the undesirable response in electrical equipment when simply turning on or off a device causes a large voltage pulse, or *spike*, to occur and go smashing through the circuitry. Power-line transients and electrostatic discharge from the human body are the two most severe forms of externally generated EMI.

**Internal EMI** is the noise generated within the system unit by the chips and other motherboard devices. With current microelectronic designs, internal noise levels are very low. Other factors, such as connections and the length of leads, have become the main sources of noise in printed circuits. Internal noise does become a problem when the components are excessively heated or when the chips begin to fail.

The last form of EMI, the **electrostatic discharge (ESD)** is the same as the effect you get from walking across a carpet and then getting shocked upon touching a metal doorknob. ESD can cause the notorious “glitch” in electronic circuits.

All these types of noise interference can produce undesirable or damaging effects in your IBM systems. They can cause programs to stop in the middle of an operation, garbage to be read from or written to disks, garble to appear on the screen, cursors to freeze, diagonal lines to appear on the television or monitor screen, paper to jam in the printer, data to disappear, and motherboard chips to be destroyed. Noise interference must be prevented by reducing or eliminating noise. This is not an insurmountable challenge, but it is a substantial practical and analytical task.

## Where Does Interference Come From?

Noise in the computer system can originate in many places, including power supplies, fans, the computer itself, other equipment, connectors, cables, fluorescent lights, lightning, and electrostatic discharge. The use of high-powered components in switching power supplies has led to widespread problems with noise being conducted back into the power lines. Switching power supplies have been found to generate EMI in the 10 to 100 kHz frequency range.

Noise can even be passed or coupled to nearby equipment that’s on a different circuit and not physically connected to the noisy system. If two wires lie next to each other, one can pick up signals coupled across from the other. This is known as *crosstalk*. Just 10 volts of electricity on one wire will cause a measurable voltage (0.25 volts) on the other wire. Imagine how much crosstalk there could be if the voltage were increased to 100 volts. The induced voltage on the other wire would be 2.5 volts, which is enough to change information in a stream of data being sent through that second wire.

Everything has some capacitance associated with it. Some typical capacitance values are shown in Table 5-1. Engineers have found that even 0.1 pF of capacitance can produce 5-volt spikes in digital circuits such as those found in the IBM personal computer.

Power-line noise can feed into the computer circuits whenever it exceeds the blocking limits of the power supply. Nearby high-voltage machinery such as stamping mills, saws, air-conditioning units, or clothes

dryers can produce strong magnetic fields in the area around them and in their power cords.

**Table 5-1. Typical Capacitance Values**

Source	Capacitance
People	700.0 pF
½-watt resistor	1.5 pF
Connector (pin-to-pin)	2.0 pF

Cables that vibrate and move in a magnetic field can also cause problems. Relays and motors can produce high-voltage transients when they are turned on or off. And televisions and radios can be affected by noise coming from the computer system.

Any digital circuit that uses a clock signal will emit, or radiate, interference off the cables connected to that circuit. The IBM personal computer CPU operates at a clock speed of over 4 MHz — inside the frequency range of radio and television signals. (Recall that RFI covers all noise that occurs at frequencies above 10 kHz.) If the PC system were not designed to correct for this type RFI, the CPU transmissions would interfere with the normal operation of nearby radios and televisions.

**Note:** Televisions on cable service would not be affected because the shielded cable allows only the cable TV program signals to get into the TV antenna input.

Finally, EMI can come from industrial, medical, and scientific equipment, electric motors, home appliances, drills, saws, and tool speed controls.

It's important to understand noise and how it can be generated. Our computer systems must be able to operate without causing interference with other nearby electronic equipment. They must be able to function without radiating noise; and they must be able to function even in an environment that includes noise being introduced from outside sources.

### Noise Interference Countermeasures

The most effective approach to noise reduction is prevention. If you can't prevent noise, you can at least take steps to minimize its impact.

Five methods for dealing with noise are:

- Filtering
- Shielding
- Bonding originals

- Wiring improvements
- Component design improvements

Usually, the approach taken is a combination of these methods, although filtering and shielding are the most widely used ways to protect electronic equipment. Filtering involves the use of capacitors and inductors. There are many kinds of filters that respond to voltage, current, or frequency. For example, one kind of filter prevents high-frequency voltage spikes from leaking out of a switching power supply into the circuitry being supported.

The following paragraphs present countermeasures used to prevent the various forms of noise interference.

#### Audible Noise

Most microcomputer systems don't generate enough audible noise to require acoustic shielding or enclosure. The normal busy office can generate about 80 dB of noise. The noisiest part of a computer system is the printer. Most printers don't exceed 70 dB of noise, but the type of noise (tap-tap printing) can become so irritating that many companies purchase insulated sound-trapping enclosures that fit over the printers and cut the noise output in half. The cooling fan in your PC's power supply can be another source of audible computer system noise.

Some computer users place acoustic sound-absorbing foam around their computer system area to achieve a quieter operating place. Acoustic pads placed under disk drives and printers can significantly reduce noise.

#### Electromagnetic Interference (EMI)

EMI is an unplanned, extraneous electrical signal that affects the performance of your computer system. It can cause memory errors and data file destruction. It can appear as power supply drift, voltage ripple, unplanned logic signals, or circuit crosstalk.

While circuit designers try to minimize EMI, it is a natural by-product of aging components, bad solder joints, damaged or corroded connector contacts, and loose connections. It is also produced when a burst of electromagnetic or electrostatic energy is conducted or induced through the circuitry. Externally produced EMI enters the computer through the cabling or openings in the case. Sometimes it enters by static discharge through the case of the disk drive.

The IBM PC case is made of metal. It is lightweight, durable and generally rustproof. While these are good qualities, the most important feature is that metal conducts electricity, so it provides protection against EMI/RFI and even ESD noise.

The Federal Communications Commission (FCC) has established specifications for the amount of radiated noise allowed to exit the chassis of computer equipment. The FCC places any devices that conduct or radiate EMI of frequency above 10 kHz into one of two categories:

**Class A**—Industrial computing devices sold for use in commercial, business, and industrial environments, and not sold to the general public.

**Class B**—Consumer computing devices used in commercial, business, and industrial applications plus personal computers and their associated peripherals.

The IBM PC is considered a Class B consumer computing device, and the EMI emitted is strictly regulated as shown in Table 5-2.

**Table 5-2. EMI requirements for class B equipment**

Frequency (MHz)	Distance (meters)	Maximum EMI Field Strength (microvolts/meter)
30–88	3	100
89–216	3	150
217–1000	3	200

Both conducted and radiated EMI are regulated. Conducted EMI in frequencies between 450 kHz and 30 MHz must be reduced by 48 dB for levels above 1 microvolt. Radiated EMI must be reduced by 46 dB or more, measured 3 meters away from the source.

To meet these requirements, IBM designed a metal shield case for the PC. While this brought the EMI within limits, some EMI still leaks out of the computer, since it gets out anywhere there is an opening on the chassis—the connector slots on the front of the chassis, the vent holes, around the power plug jack, and even the key holes on top of the detachable keyboard case.

IBM PC design engineers have employed most of the following techniques to reduce EMI and RFI:

- Use decoupling capacitors (0.01  $\mu$ F to 0.1  $\mu$ F).
- Lay out components carefully.
- Keep traces as short as possible.
- Minimize the use of transistor-transistor-logic (TTL) chips since they tend to generate current spikes when switching logic states.
- Shield sensitive circuits.
- Reduce noise sources.
- Use fewer components.
- Carefully route wires.
- Use a shielded cabinet with as few openings as practicable.

How can you improve on IBM's efforts to counteract EMI? Since you won't be changing the circuit board design, you can reduce EMI in two ways: (a) prevent it from reaching the motherboard and interface card circuits, and (b) keep it contained within shielded enclosures. To do this, use shielding, grounded cables, filters, and transient absorbers.

Metal enclosures make the best shields. The PC's switching power supply, a high source of EMI, is enclosed in a metal can. The greater the shield thickness, the better the shield effect. While the metal computer case of your IBM PC does a decent job of shielding against EMI and RFI, you can improve on the shielding by sealing all openings that aren't being used. Compressible gaskets can be used to close slot holes. At one time IBM shipped each PC with metal gaskets over each adapter-card access hole. This practice was discontinued—apparently because the gaskets kept falling out during shipping. Metal honeycomb ventilation screens can be used over cooling vents.

Buy and use shielded cables. A shield is a conductive coat or envelope placed around a conductor wire or group of wires to provide a barrier to electromagnetic interference. Ground the shields. Have you hooked up the ground wires that are attached to some of the peripheral interface cables? If not, you really should. A shielded computer connected to a poorly shielded peripheral will enable any interference generated inside the computer to be conducted to and out through the shield weaknesses. Filtering inside the cabling or connectors will eliminate conducted noise.

Some connectors can be purchased with built-in filter pins to reduce radiated EMI count around connectors. Other EMI-reduction devices include the ferrite "shield beads" that are placed on power supply leads and connections to ground or between stages on the circuit board.

Ideally, the shielded connectors should provide a continuous shield from the device, through the connector, and into the shielded cable. Otherwise, the weak shield point becomes a transmission hole for EMI to get out and interfere with other devices or appliances in the area.

One excellent countermeasure to EMI and RFI is the use of fiber-optic cables and connectors. This technology hasn't yet become popular with PC users because the cost is still too high, but the day is coming when fiber-optic data transmission will be the norm rather than the exception.

**Electrostatic Discharge (ESD)**

It sometimes appears that a secret program is loaded into every computer to intermittently produce random errors to drive users wild. Chasing and catching the elusive phantom "glitch" is a challenge even for experienced repair technicians using expensive and complex troubleshooting equipment. However, you can learn more about this intermittent problem and how to prevent it from affecting your computer operation.

Glitches are electrical disturbances of short duration, but they are often long enough to cause problems in digital circuitry. They are usually the result of an electrostatic discharge (ESD), one of the most severe sources of EMI.

People and objects such as chairs and desks can accumulate a substantial electrical charge, or potential. The human body can accumulate static charges up to 25,000 volts. It is not unusual to build up and carry charges of 500 to 15,000 volts. Charged objects or people can then discharge the voltage to a grounded surface through another object or person. Remember the times you dragged your feet across the carpet and then shocked someone nearby? This electrical charge is called *static*. It can discharge through your computer, and when it does, all sorts of undesirable things can occur. If a program is running and a computer user carrying a large electrical charge touches a key on the keyboard, the arc of discharge will find the shortest route to ground, usually through the RAM or CPU, and the program will bomb to a halt, data bits "falling away" everywhere. The screen can go wild and display strange characters. Sensitive components can be damaged or destroyed. Even a charge of only 3 volts is enough to create an erroneous bit in most logic circuits.

Electrostatic charges can be of any voltage. The following is a list of some of the sources of ESD glitches:

- People in motion
- Overheated components
- Improper grounding
- Poorly shielded cables
- Improperly installed shields
- Missing covers and gaskets

- Circuit lines too close
- Poor solder connections
- Low humidity

We know that static occurs when two objects are rubbed together. Your movement, walking while wearing wool or polyester slacks, can cause a tremendous charge of electricity to build up on your body. When this charge reaches 10,000 volts, it is likely to discharge on any grounded metal part.

Litton Systems, Inc. has developed the *triboelectric series* chart shown in Table 5-3. Cotton is the reference material since it absorbs moisture readily and can easily become conductive. If any material on the list above cotton is rubbed with any material on the list below cotton, the item listed above will give up electrons and become positively charged. The item listed below cotton will absorb electrons causing it to become negatively charged.

**Table 5-3. Litton Systems, Inc. Triboelectric Series**

	Air
	Your hand
	Asbestos
	Rabbit fur
	Glass
	Your hair
	Nylon
	Wool
	Fur
	Lead
	Silk
	Aluminum
	Paper
Reference material* →	Cotton
	Steel
	Wood
	Hard rubber
	Nickel, copper
	Brass, silver
	Gold, platinum
	Acetate, rayon
	Polyester
	Polyurethane
	Polyvinyl chloride
	Silicon
	Teflon

\*When a material above cotton is rubbed with a material below cotton, the material above will become positively charged and the material below, negatively charged.

The two oppositely charged materials will tend to cling together. If they are separated, a static charge difference occurs. If Teflon is rubbed in your hands, a large electrostatic charge is built up. The greater the distance between the materials listed in Table 5-3, the

larger the charge that can build up. Notice that hair is listed above cotton, paper is listed just above cotton, and hard rubber is below cotton. Have you ever pulled a rubber or plastic comb through your hair and then used the comb just like a magnet to pick up pieces of paper? This is electrostatic charge in action.

Our problem occurs when this charge builds and becomes quite large. Just walking across a carpet can generate over 1000 volts of charge. If the humidity is low and it is quite dry in the room, the charge can be substantially higher. (When the relative humidity is 50 percent or higher, static charges generally don't accumulate.) A built-up static charge will readily arc to any grounded metal, such as a disk drive chassis.

An ESD release on your disk drive case won't hurt you, but it can be very damaging to your electronics. The discharge pulse drives through the case to the read/write head and then on to the analog card circuitry, where it can burn out some of the chips. Even if no components are "fried," the damage that is done by this overvoltage spike accumulates and starts to degrade the functioning of some circuit board components. ESD damage costs have been estimated at millions of dollars annually, but this figure is even higher when we include components that are not totally destroyed, but are degraded. Even so, sooner or later the chip(s) fail completely.

In low humidity, walking across a synthetic carpet can charge your body to 35,000 volts. Walking over a vinyl floor can charge you with 12,000 volts. A clear plastic ("poly") bag picked up off a table can develop 20,000 volts. Even sliding off a urethane-foam padded chair can load you with 18,000 volts. Is this a hazard to your PC? Yes. As Table 5-4 describes, some electronic devices are very susceptible to relatively low ESD voltages.

If your computer occasionally gets the "shock treatment" or pulls the old "disappearing data" trick on you, there are some things you can do. The following list offers some specific solutions to ESD problems.

- Use antistatic spray on your rugs, carpets, and computer equipment. The antistatic spray, applied with a soft cloth works both as a static reducer and control measure.
- Install a static-free carpet in your computer area.
- Install an antistatic floor mat beneath your computer chair. (This is a popular solution.)
- Mop hard floors with an antistatic solution. The antistatic floor finish works well, but this is really

**Table 5-4. Voltages that can damage electronic devices**

Device	Damaging Voltage (minimum)
CMOS chips	250–3000 volts
Diodes	300–2500 volts
EPROM memory	100 volts
Operational amplifier	190–2500 volts
Resistors	300–3000 volts
Schottky (S, LS) chips	1000–2500 volts
Transistors	380–7000 volts
VMOS chips	30–1800 volts

an expensive solution and better suited for electronic manufacturing facilities. Most antistatic floor finishes work for up to 6 months.

- Install a conductive table top.
- Install a humidifier to keep room humidity above 50 percent.
- Use static-free table mats.
- Keep chips in conductive foam (that black styrofoam-looking material).
- Touch a grounded metal object (power supply case) before touching the computer.

You can defeat ESD glitches by paying attention to static charge in and about the computer system. By making static charge elimination a part of your preventive maintenance program, you take one more step to extending the life of your computer system.

### Radio Frequency Interference (RFI)

Radio frequency interference is much the same as EMI, except that it occurs at higher frequencies (>10 kHz). RFI is what causes five other garage doors on your street to open when you operate your new automatic garage door opener.

Although RFI isn't a health hazard, it's also controlled by the FCC. FCC Rule, Part 15, Subpart J states that any digital product that generates timing signals or pulses at rates greater than 10 kHz must comply with FCC regulations. In fact, Class B devices such as the IBM personal computer are tested over a range of 30 to 1000 MHz to ensure that their emissions fall below maximum field-strength limits. The computer is also limited in the amount of emission that it can feed back along the power lines (no more than 250 microvolts). The same standards that apply to EMI field-strength radiation also apply to RFI (see Table 5-2).

The only sure way to completely block RFI emissions is to completely enclose your computer system in

a shield. This is impractical, but there are other ways to reduce the emission of RFI.

A smaller component count in a computer reduces the number of sources of RFI and improves system operation. Reliability improves in direct proportion to RFI improvements.

There are some actions that you can take yourself to improve your system's RFI condition.

- Locate your computer system at least 6 feet away from any television set.
- Reposition the outside TV antenna if interference occurs.
- Use a directional outdoor TV antenna.
- Subscribe to cable TV.
- Connect traps or line filters on your TV.
- Replace the antenna twin-lead wire with 75-ohm coaxial cable.

With current computer designs and FCC direction, the RFI emissions from personal computers are so low that interfering with your neighbor's TV set is no longer a problem. However, they can still interfere with your own TV set.

There have been reports of interference problems with cordless telephones. The PC has been known to cause low power telephones to dial or lift off hook. High power telephones in the vicinity of the PC have caused characters to appear on the monitor screen. Usually the keyboard is the source of the problem. If you use a cordless telephone, you might consider investing in a better shielded keyboard such as the Keytronics board.

## POWER-LINE PROBLEMS

Probably the most important environmental factor for your computer system is good, clean power. If you depend on your local utility to supply this power with steady, reliable consistency, you may be disappointed.

While room lighting systems can tolerate line voltage problems that momentarily dim the lights when a large power-hungry machine is switched on, computer systems cannot. Your IBM computer, like most electronic computers today, is more sensitive to power-line disturbances than other electrical equipment is. Even well-designed machines such as your IBM PC are affected by the quality of power provided. Under-voltage or overvoltage puts severe stress on computer components. The effect accelerates the conditions

under which a device gradually weakens, becomes marginal, and finally wears out.

There are four types of power-line problems that cause concern:

- Brownouts
- Blackouts
- Transients
- Noise (discussed previously)

### Brownouts

Brownouts are those planned (and sometimes unplanned) voltage sags, when less voltage is available to drive your IBM PC power supply, display CRT, and printer motor. Brownouts are far more common than you may realize. Voltage dips are common if you operate your computer near some large electrical equipment such as air conditioners or arc welders. Your line voltage can be drawn down as much as 20 percent by the heavy momentary drain caused when this equipment is turned on.

The PC should still work with line voltages that drop and remain as much as 20 percent below the 117 volt rating. But if the supply voltage gets too low, the regulators in your power supply won't be able to pump adequate power into your motherboard, and data can get garbled. During brownouts, computer systems can operate intermittently, overheat, or simply shut down and lock up.

By the way, your power supply can also handle a voltage "brown-up," or increased line voltage. The power supply will provide proper power to your circuit, but its regulators will generate a lot more heat as they handle the higher incoming voltage level.

### Blackouts

Power-line blackout, a total loss of line voltage, can be caused by storms and lightning. It can be caused by vehicles accidentally knocking down power lines or even by improper switching action by a power station operator.

When power is lost, whatever you had in RAM is gone. If you are writing to the disk when power fails, you will have only a partial save—the information that was still in RAM and not yet copied over to your disk is lost. If a scheduled power outage is planned, postpone using your computer. If the weather turns bad and thunder is echoing across the sky, don't turn your computer on. If a blackout occurs or if you see lightning,

turn your machine off and pull the plug(s) until the storm passes.

And when the power goes out, be careful. While the room lights are out and you're muttering under your breath as you feel around for a flashlight, remember what is sure to happen when power is restored—a tremendous voltage spike will be produced as lights and motors go back on all over the neighborhood. This could damage the IBM PC system. Always unplug your computer system when blackout occurs. Wait until power has been restored for a few minutes, then turn your system back on. Don't test your power supply filters on these kinds of spikes.

## Transients

Other than electrostatic discharge, power-line transients are the most devastating form of noise interference in computer circuits. Transients are large, potentially damaging spikes of voltage or current that are generated in the power lines feeding electrical power to your community. Spikes can be caused by lightning striking a power line somewhere, utility company equipment failure, or the ON/OFF switching action common to using any electrical tool or appliance.

Most of these spikes are small and are barely noticeable, but some voltage spikes as large as 1700 volts have been measured in home wiring. Residential areas experience more large spike transients than commercial areas. The line filters in your IBM power supply will protect your system from most high-voltage transients, but occasionally a spike overcomes the power supply protection and gets to the logic circuitry. The general effect is erased or altered data, but if the spike is too large, sensitive circuit devices can be destroyed.

Your PC power supply is normally not affected by the transients generated by ON or OFF switching actions. These actions can produce a short-lived spike that is five times normal line voltage.

Not all spikes are generated outside the computer. When you save a program or file you've developed, activating the disk drive produces a voltage spike inside your computer. IBM engineers have placed capacitors in strategic locations on the motherboard and in the disk drive electronics to carry spikes harmlessly away to ground, preventing component damage. If any part of the spike reaches the circuit components, the devices are stressed and can become marginal.

## Preventing Power-Line Problems

If you live in an area where power outages or brownouts are common, or where electrical storms fre-

quently occur or if your computer system occasionally hangs up, you need protection. There are two kinds of approaches to preventing power-line problems. You can condition the power being supplied, or you can provide an auxiliary, or backup, power source.

### Power-Line Conditioners

The various forms of **power-line conditioners** include the isolator, the regulator, and the filter.

**Isolators** provide protection from voltage and current surges and include transient suppressors, surge protectors, and isolation devices. These devices can keep line voltage at a proper level even when the line supply is 25 percent over normal. Some surge protectors can filter out high-frequency spikes but cannot respond to slow, low-frequency transients. One form of surge protector is called a *metal oxide varistor (MOV)*, a form of diode that will clamp the line voltage at a certain level, preventing overvoltage spikes from getting into your system. These devices are installed across the power-line wires leading into your computer. The December 1983 issue of *Byte* magazine has a good article on the installation of MOV devices, should you be interested in using them. Isolators cannot provide protection against brownouts or complete loss of electrical power.

**Regulators** act to maintain the line voltage within prescribed limits. They are essential if line voltage varies more than 10 percent at the computer, but they don't provide protection against voltage spikes and blackouts.

**Filters** remove noise from the input power line. They short EMI and RFI signals to ground and remove high-frequency signals from the low-frequency 60 Hz power line. Power-line filters work best when they are located immediately next to or at the front end of the power supply. Filters don't stop spikes. Nor are they effective during low- or high-voltage conditions.

### Auxiliary Power Sources

When power availability is in question, an **auxiliary power source** is a necessity. An **uninterruptible power supply (UPS)** is used to store energy when line power is present and then deliver power to the computer when a blackout occurs. These power supplies cost between \$300 and \$15,000, but they are a dependable source of auxiliary power. A UPS is composed of a motor, a generator, and a battery. The motor is driven by power from the utility line while local power is available. The motor turns a generator that produces electricity to charge a battery. When the local line power is lost, the

battery turns the generator to produce AC electricity that can be used by the computer.

There are four types of UPS equipment that can be used to power your computer system:

- Continuous-service UPS
- Motor generator
- Forward-transfer UPS
- Reverse-transfer UPS

A **continuous-service UPS** changes the AC line voltage to DC to charge a set of batteries. When power is lost, the batteries operate an inverter that changes the DC battery power back to AC to run your computer.

Portable and fixed **motor generators** are powered by electricity, gasoline, or diesel motors. The generator is turned by the motor and supplies a regulated AC voltage to operate your computer system (and probably many other appliances and lights in your house or business). These devices are often used as emergency backup power for hospitals, police departments, and radio stations. Generators can be expensive, but they can provide backup power throughout the period line power is not available.

A **forward-transfer UPS** supplies power to your computer system only when line power is lost. It is the classic UPS, in which the line power drives a motor that rotates a generator that charges a battery (or set of batteries). When line power is lost, the batteries take over and provide AC power to the computer through an inverter.

A **reverse-transfer UPS** provides power to the computer from a battery most of the time, and switches to line power only if the UPS fails or is turned off.

Some UPS equipment provides much more than just a power source. One company markets a UPS that provides protection not only against complete power loss, but also against power transients, undervoltage and overvoltage fluctuations, brownouts, and dirty (noisy) lines. Most UPS devices can switch to battery power very quickly. One UPS makes the transfer from primary power to battery power in about 4 milliseconds.

Once the transfer occurs, the next important consideration is the length of time the backup will be able to provide power. Some units will keep your computer system running long enough to save what you had in RAM and to conduct a normal system shutdown. A unit from Topaz Inc. in San Diego, California can provide up to an hour of reliable AC power. It sells for about \$800.

How important is a UPS and the length of time it can provide power? If you are in an area that suffers fre-

quent power outages, consider this: what effect would losing power at the time you were updating your disk directory have on your system? You'd probably lose your directory and not be able to retrieve whatever you had on your disk. The problem can be much worse when you connect a hard disk into your system. If a power outage occurs when the hard disk is activated or even simply powered up, there is no way for you to conduct a normal power-down sequence. If your hard disk requires the read/write heads to be in a certain position, you can't achieve this unless you have a UPS that switches in instantaneously. Failure to properly position the heads can cause drive damage as well as loss of valuable data.

You have some choices. What level of insurance do you need? Can you manage adequately without standby power—making backup copies of all your data and saving to disk often during computer operation? Power-line protection can prevent damage, expensive data loss, and unnecessary down-time.

When selecting a power-line conditioner or a backup power supply, consider the following parameters:

For a power-line conditioner

- Speed of response in handling voltage spikes
- Ability to filter out high-frequency noise
- Ability to handle repeated transients
- Amount of line power it can handle
- Range of input voltages from which it will produce clean power out
- Number of outlets (to handle several devices)

For a backup power supply

- Total backup power required
- Time to switch to standby power
- Length of time backup will provide power
- Availability of built-in line conditioning
- Availability of undervoltage and overvoltage protection
- Battery life cycle

To determine how much backup power you may require, add the amperage ratings on the label plates of all the computer system equipment (computer, external display monitor, printer, drives, plotters, etc.) and multiply by 120. The result is the approximate wattage, or power, you will require to operate the entire system. Since the larger the amount of power required, the

higher your cost, you may want to consider only the power required to operate the basic system (computer, monitor, and disk drives). You can leave the other peripheral equipment plugged into your standard wall socket and let these fail off when power is lost. If you do this, don't forget to turn these machines off and unplug the power cords before power is restored to prevent a big transient from damaging them.

How much power protection to provide is up to you. Many computer users are able to get along quite well with unprotected systems. Others prefer to operate their systems knowing that unseen environmental upheavals won't affect access to their IBM PC.

## CORROSION

The metal connector pins on cables, interface cards, and chip pins are subject to corrosion, a chemical change in which the metal plating of the pins and sockets is gradually eaten away. Corrosion can be very damaging.

There are three types of corrosion that can affect the IBM PC system:

- Direct oxidation by chemicals
- Atmospheric corrosion
- Galvanic electrical corrosion

### Direct Oxidation

In direct oxidation a chemical corrosion occurs. A film of oxide forms on the metal surface, reducing the pin's contact with the socket. At high temperatures this oxidation process accelerates. The metal is slowly worn away as the electrical contact surface is converted to an oxide and the oxide crumbles.

### Atmospheric Corrosion

Chemicals in the air attack the metals in computer system circuitry, causing pitting and a "rust" build-up. In the early stages of this corrosion, sulfur compounds in the atmosphere are converted to tiny droplets of sulfuric acid that lie on the surface of the connector pins. This acid eats away the metal, causing pits to form.

When atmospheric corrosion is just forming, the contacts can be wiped clean, restoring the metal brightness. But if the sulfuric acid is allowed to remain, the long exposure converts the acid to a sulfate layer that can no longer be wiped away.

The effect is to reduce electrical contact between the pins and their sockets. A layer of discolored rust that prevents any contact between the pins and their sockets causes an open circuit and is easy to locate. It's the in-between stage, when an "almost-open" condition exists, that produces those horrible intermittent failures that can be so hard to find.

Near the ocean the presence of salt spray or increased levels of chlorides can cause severe pitting of some metals.

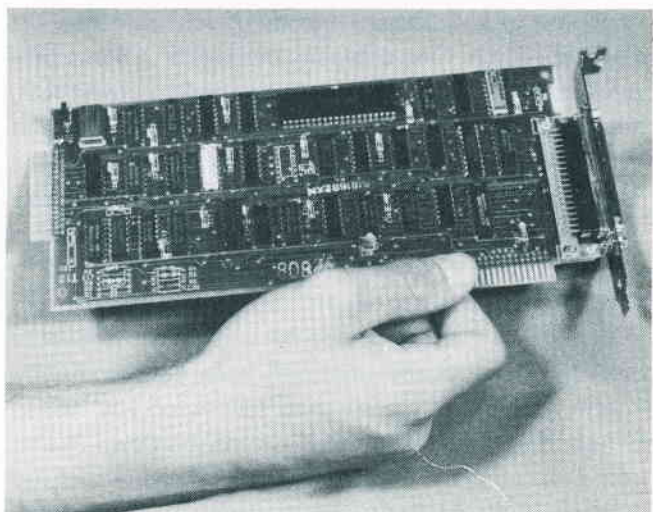
## Galvanic Corrosion

In galvanic corrosion, a tiny crack or hole in the metal plating on a pin or connector lets a moisture-borne electrolyte such as salt (sodium chloride) penetrate between the metal plating and the underlying base metal.

A kind of battery forms, with a tiny electric current flowing between the two metals. The plating surface becomes scaly and rough as the plating is slowly eroded away and an oxide forms. The corrosive action is concentrated on the underlying metal exposed at the breaks in the scale since this is where the galvanic battery exists.

The effect is the same as for the other forms of corrosion—the amount of electrical contact between pin and socket decreases, causing intermittent problems, until the scale is so complete the electrical circuit is broken and signals are blocked entirely.

You can cause this corrosive action to start if you handle your connectors and boards improperly. The wrong way to handle printed circuit boards is shown in Fig. 5-6.



**Fig. 5-6.** Handling a printed-circuit board the WRONG way can cause corrosion.

**Note:** Never touch contacts with your fingers. The oil on your fingers contains enough sodium chloride to begin oxidation action on those pins.

## Corrosion Prevention

While metal gates and cars can be spray painted to prevent rust (oxidation), this is not an option for preventing corrosion on circuit pins and connectors. The best preventive action is cleaning. By keeping the contacts clean, you can deter oxidation build-up.

You can clean the pins on some chips by reseating the chips periodically. Chips have a habit of working up out of the sockets after extended use. Turning off all the power and carefully pushing these devices back down into their sockets will act to clean the pin surface, restoring (or ensuring) good electrical contact.

**Caution:** Always turn off the power and touch a grounded surface before touching anything inside the IBM PC.

Oxidation of the contacts of connectors on the motherboard and disk electronics boards can be cleaned with a soft rubber eraser, a solvent wipe, or a contact cleaner spray.

**Caution:** When rubbing to clean contacts, always rub along the pin (lengthwise). Rubbing lengthwise on the pins prevents accidentally pulling a pin contact up off the board.

Do not use emery cloth or any abrasive cleaners to clean the contacts. If you use a rubber eraser, keep eraser dust away from the computer.

Solvent wipes are available as part of cleaning kits sold by many computer supply companies. These wipes can clean and then lubricate the contact surface with a film that helps seal out atmospheric corrosion without interfering with signal flow. Most solvent wipes are individually wrapped in small packages much like the hand towelettes you get in some restaurants or on some airplane flights.

Spraying the pins with a contact cleaner spray (available at most electronic parts stores) is also an effective corrosion preventive. Contact cleaner wipes and spray are the best methods for removing an oxidation layer.

There is a trade-off between preventing corrosion and preventing electrostatic discharge, because corrosive action is reduced with a reduction in the relative humidity, but ESD increases.

Manufacturers of electronic equipment are aware of the effects of corrosion, and most connectors are

made of a combination of metals that resist corrosion but are good conductors of electrical signals. You can choose the type of connectors to use for your cables. You can buy cables and connectors with tin alloy plating on the pins or with a thin gold plating. Although you will pay more for the gold-plated connectors, they provide superior contact reliability. Gold-plated contacts don't wear out as tin alloy surfaces do, but even the tin surfaces take a long time to wear away; so a sound, consistent cleaning program can really help.

One final note on the subject of corrosion: high temperatures will increase the corrosive action in the IBM PC system. It helps to keep your computer tuned up and running cool.

## MAGNETISM

The effects of magnetism are especially important in disks and disk drives, since these two parts of the computer system are designed to operate on magnetic principles.

Each floppy disk is coated with a magnetic oxide with millions of tiny pole magnets randomly positioned on its surface. As the drive write head passes over the disk surface, a magnetic force is induced in the head by the disk drive electronics, causing the pole magnets on the disk surface to line up according to the digital information being converted to voltage pulses in the head. This is "good" magnetism.

### Sources of Magnetism

The voltages used in monitors and television receivers produce strong magnetic fields. These can be bad. If you accidentally place one of your disks in the field, the tiny pole magnets on your disk's tracks can change their alignment. Then, when your disk drive tries to read the disk, the head cannot understand or can misinterpret the information on the disk, and you get garbage or BDOS read errors.

Magnetic flux is caused by the presence of a high (115 V) voltage in computer display monitors and televisions. A color television produces the strongest magnetic flux, but high-voltage areas of monitors, printers, telephones, ballasts in fluorescent lights, and even power strips can be sources of offensive flux and can cause intermittent data loss. The strength of the flux field depends on the strength of the voltage, which can fluctuate with the amount of power being required by the equipment.

## Preventing the Damaging Effects of Magnetism

To avoid the damaging effects of magnetism, keep your diskettes, and even your information cables, away from power sources and magnets.

## DISK MAINTENANCE

Two valuable components in any computer system are the mass storage devices (disks) and the disk drives. IBM PC systems use 5¼-inch floppy disks as the mass storage medium. Technically they are called *diskettes* to differentiate them from the *disks* used in 8-inch drives, but the terms “floppy” and “disk” are so commonly used with the 5¼-inch diskettes that the term “disk” will suffice. Since disks and disk drives are such critical components in computer systems, it makes sense to do all you can to protect and maintain them.

The read/write head in an IBM PC disk drive rides on the surface of the most vulnerable part of the mass storage system, the floppy disk. Floppy disks are made of Mylar or polyethylene terephthalate and coated with a magnetic iron (ferric) oxide. The oxide-coated Mylar disk or “cookie” is placed in a protective polyvinylchloride jacket (refer to Fig. 5-2).

Disks make different sounds in the disk drive, depending on the type of liner used. Some types of liners provide more wiping action than others. The disk may sound like coarse sandpaper when it spins in the drive, but that doesn't mean the disk surface or the drive is being harmed. A louder disk may actually be doing a better job than a quieter disk.

## Harmful Substances

Disks are pretty sturdy things, but they are sensitive to magnetic and electrical fields, high temperature, low temperature, pressure, bending, and dust. Dust and little airborne fibers are particularly bad for your disks. With the drive read/write head riding on the surface of the disk, any tiny piece of “junk” lying on your disk looks like a huge boulder to the head. A piece of your own hair is about 40 microns (.0015748 inch) thick. A hair is a huge obstruction to the disk drive head. Even dust and fingerprints on the disk surface can be obstacles to the even movement of the disk under the head. To protect the disk medium and the head, each disk jacket is lined inside with a dust catching synthetic fiber. As the disk is rotated inside the drive at a whopping 300 rpm, dust and other particles that may have slipped inside

the jacket or settled on the disk are quickly swept off the disk by the liner material. But a build-up of too many particles can overload this protective system.

Another substance that is harmful to disks and disk drives is tobacco smoke. The tars and nicotine that filter up into the air from the ends of cigarettes and cigars (or out of the lungs of smokers) can settle on your computer system. These sticky chemicals form a gummy ash build-up on any exposed surface—including your disks and your disk drives. This material gums up the drive, eats into the read/write head, and scratches the surface of your disks. The effect is similar to taking a metal file to your favorite record album. Avoid smoking or allowing smoking in your computer area. If you can't do this, then clean your system more often.

Disks are further protected by the paper storage envelopes, or sleeves, into which the square disk jackets are inserted. Use these envelopes. Don't let your disks lie around outside their envelopes inviting dust and dirt trouble.

Not all disks are created equal. Some disks are manufactured to better standards and with thicker magnetic oxide coatings. Naturally, these disks are more expensive. Less expensive disks have thinner oxide coatings and shed their oxide layers easily, further reducing their effective life. Compare disk specifications before you buy.

Depending on the quality of your disks, the cleanliness of your computer area, and the condition of your disk drive, your disk life could be as short as a week or as long as 17 years (70 million revolutions). Assuming the quality, cleanliness, and condition factors are favorable, disk life is estimated on actual rotations while the disk read/write head is in contact with the disk surface, rather than on total time of existence.

As the drive head rides on the disk's oxide surface, it causes tiny bits of oxide to rub off the disk. Most of these loose oxide particles are caught and held by the liner, but some of the oxide sticks to the head. Gradually an oxide layer builds up. This oxide layer has two effects on system operation: (a) it makes the head less sensitive to reading and writing data, and (b) it causes an abrasive action on the disk surface. As the oxide layer builds up, it becomes ragged. This roughness scratches even more oxide off the disks, until the oxide on the disk surface is too thin to support data storage. When oxide is missing from the surface, “drop-outs,” or spots where data can no longer be stored, develop. Then the disk fails to read or write properly, and it becomes useless.

Keeping this oxide layer from building on the read/

write head will help extend the life of your disks. The better disks are less likely to spin off oxide particles, so the head stays cleaner longer, and the disks last longer.

## Extending Disk Life

Here is a summary of what you can do to help extend disk life.

1. Buy name-brand disks. Avoid "bargain" disks. The \$7 disk should last 7 times as long as the \$1.50 disk.
2. Never touch the disk surface.
3. Never slam the disk drive door closed on a disk. You could press the disk-centering hardware into the disk surface instead of the disk hole.
4. Store disks in their protective jackets.
5. Never write on a label that's already mounted on a disk. Ball-point pens and pencils can cause indentations in the disk surface. Mark the label first, and then put it on the disk jacket.
6. Store disks in a cool, clean place.
7. Back up everything.
8. Store working disks and backup disks in different places.
9. Don't lay disks in the sun. They warp just as stereo records do.
10. Never allow smoking near your disks or your drive. Smoke lets tars settle on the disk surface (and inside your drive), gumming up the works.
11. Never set disks by monitors or televisions. The magnetic fields can erase data.
12. Avoid placing disks near vacuum cleaners or large motors. Even freezers and refrigerators have compressor motors that can alter data on your disks.
13. Don't bend or fold disks.
14. Store disks vertically. Storing disks horizontally can cause the disk to bind in the jacket, preventing proper speed of rotation, causing scratching of the disk surface, and resulting in intermittent failure.
15. Don't put disks through airport x-ray machines. Hand them to the security guard for inspection, so that they can bypass the x-ray inspection process.

## Flipping the Floppy

Before we get into PM for disk drives, for those of you with single-sided drives, let's clear up a few misconceptions about disk use in a single-sided disk drive system. Many people believe that you can flip your disk over, cut an additional write-protect slot into the jacket, and then use the flip side of the disk to store more programs and data. They contend that using the back side of a disk in a single-sided drive system won't cause any problems with either the disk or the drive. Some reputable magazines and IBM users groups support this idea. Disk drive manufacturers strongly disagree. Who is correct?

When the door is closed on a single-sided disk drive, a pressure pad comes in contact with the disk, pushing it against the drive read/write head, which rides on the surface of the inserted disk. The drive motor rotates the disk in only one direction, at a speed of 300 rpm. As the disk wears, tiny bits of oxide come off the disk and are swept up and held by the liner inside the disk jacket; or they build up on the drive read/write head. Some oxide even builds up on the pressure pads.

Disk manufacturers test both sides of a disk, and if one side fails they often place the defective side in the disk jacket so that only the good side is exposed when the platter is marketed as a single-sided disk.

The disk jacket liner, catching up most of the oxides, dust, and dirt that gets on the disk surface, functions the same way as a lint brush being used on a dark wool suit. Brushing in one direction removes the lint and hair, but brushing in the opposite direction, wipes the collected lint back onto the suit. The same thing happens with disks in lined jackets. As the drive spins the disk in one direction, the lint, dust, and whatever else is on the disk surface is wiped up by the liner. If the disk is turned over and rotated in the opposite direction, the "junk" collected by the liner gets wiped off and back onto the disk. The excess dirt in the liner scratches more oxide off the disk. You begin to experience "drop-outs" in the areas of the disk that no longer have enough oxide left to store digital information. The read/write head gets dirty even faster; even the pressure pad build-up increases.

Even the act of cutting an additional write-protect notch in the disk jacket causes problems. The polyvinyl chloride jacket material shatters when cut, producing tiny shards of polyvinyl chloride that can scratch the disk surface and add to the material collected by the liner.

Another problem occurs with the pressure pads

themselves. When you flip your disk, you are placing the "good" side of your disk in contact with the rough, oxide layers built up on the pads. Rotation of the disk now causes scratches on that side of your disk.

One last additional hazard caused by writing data on both sides of a disk is the potential for magnetic field "bleed-through." Writing on one side of the disk creates a magnetic field which affects the data stored on the opposite side of the disk. Bleed-through is one indication that a disk is wearing out. Disks that are manufactured for two-sided storage have slightly thicker magnetic oxide coating, reducing the risk of bleed-through.

The evidence seems clear. You can use both sides of a disk, but you do so at a certain risk.

## DISK DRIVE MAINTENANCE

What kinds of PM are there for disk drives? If you owned a \$100-million-a-year company using hundreds of disk drives, you could plan for and purchase a \$50,000 disk drive tester that tests four drives at a time using dual microprocessors. But you probably don't own a \$100-million company. So how can you test and maintain your own disk drive(s) without this expensive equipment?

Disk drive manufacturers' representatives insist that "officially" there isn't any PM required for disk drives. They describe head cleaning as the only routine maintenance that can be done by a novice, although even this is not officially recommended. Why not? Suppose you were a disk drive manufacturer with lots of repair and testing facilities. Would you be inclined to recommend owner-conducted maintenance that would make your drives last years longer before repair was required? The repair business is big business. The less maintenance you do, the sooner your system will start giving read/write errors and the more work you will provide for repair companies.

Here are some facts about disk maintenance procedures:

1. Heads need cleaning to remove the oxides from your disks that build up on the leading edge of the head (the side facing the direction of disk rotation), as shown in Fig. 5-7.
2. Head cleaning is a PM procedure you can do. Head-cleaning diskettes of various kinds are available. The "wet" diskette kind works with a cleaning solvent.

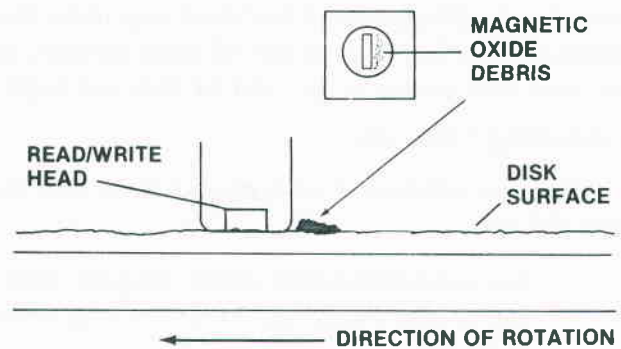
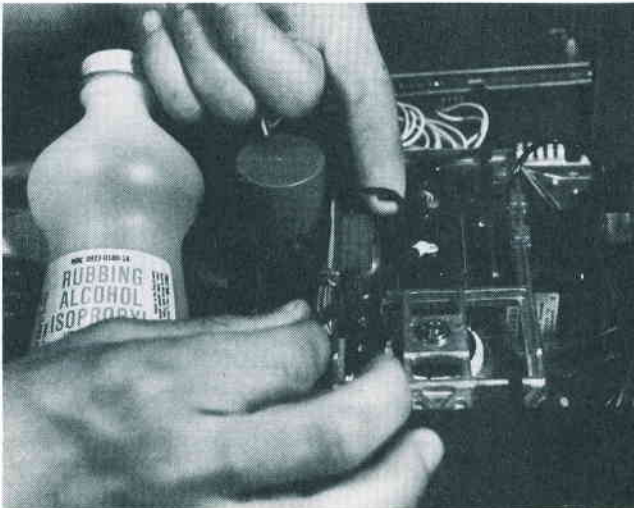


Fig. 5-7. Oxides are wiped off the disk surface and build up on the head surface.

3. Some head cleaners are abrasive and can damage the head if they are used for too long. If you buy this type of cleaner, you must use the cleaner just long enough to remove the oxide build-up but not long enough to damage the head.
4. New nonabrasive head cleaners are being marketed. Two examples are Verbatim's Data-life head-cleaning kit, and Innovative Computer Products' Perfect Data head-cleaning kit. Both products use fabric-covered disks which are dampened with a cleaning solvent. With the one kit, you sprinkle cleaning solvent on the disk fabric and then insert the disk into your drive for spinning action head cleaning. The head-cleaning disk can be used as many as 13 times. The other kit has cleaning disks that are predampened and individually sealed. With this kind of system, you use a cleaning disk once and then throw it away, using another the next time. Both of these products work well.
 

Since any cleaning disk works by rubbing action and chemical action between the disk fabric and the drive head, there is potential for abrasion to occur. So you must be careful not to leave the disk spinning in the drive for too long. A cleaning disk can be allowed to spin in a disk drive for 30 seconds with no apparent damage. With most cleaning disk kits, 45 seconds is too long to keep the cleaning solvent in contact with the drive head.
5. Drive heads can also be cleaned with alcohol and a cotton swab wrapped in a lint-free material (see Fig. 5-8). With manual alcohol-and-swab cleaning, you could accidentally scrub the pressure

pads by mistake, causing more problems than you're preventing. But if you're careful, manual cleaning can be effective.



**Fig. 5-8.** Drive read heads can be cleaned using isopropyl alcohol and a lint-free swab.

Special cleaning material such as cellular-foam swabs and chamois leather cloth are good materials to use for manual head cleaning. Or you can use a piece of bed sheet wrapped around the cotton swab. Uncovered cotton swabs are dangerous because the cotton fibers can catch or pull away and lie in the drive or on the head, becoming cotton logs on a disk-surface highway, waiting to get swept into the drive head that rides on the surface of the disk. These fibers can also catch on the ferrite chip in the middle of the ceramic head, loosening it from its mounting and ruining the head.

Surgical isopropyl alcohol or methanol can be used as the cleaning solvent. The solvent used must not leave a residue when it evaporates, so most other alcohol solvents should be avoided. You can also use typewriter cleaner or trichloroethane. In all cases use plenty of ventilation and make sure the solvent has evaporated before you operate the drive.

6. How often the head must be cleaned depends on how much the drive is used and what types of diskettes are used. A high-quality diskette is good for about 3 million passes, or rotations, against a read/write head before enough oxide is worn off so that the head needs cleaning. The

“bargain” disks are good for one tenth the rotational life. This means that instead of 167 hours of access time, you might get 16 hours or less before the head gets caked with oxide or your disk surface gets too worn to write to or read from. Now you know why your bargain disks don't seem to last very long.

A useful rule of thumb for head cleaning is to clean the read/write head every 40 hours of disk operation. This means clean after 40 hours of rotational life if you're using standard disks. You could clean more often or even wait until you start getting read/write errors and then replace or clean the head.

7. Keeping the drive door closed unless you are inserting or removing a disk will help keep dust and dirt out. It also keeps unwelcome visitors (such as insects) from climbing into the drive.

### Cleaning the Disk Drive Head

To clean the drive head using a cleaning disk:

1. Turn the computer power on.
2. Dampen the cleaning disk with the solvent supplied.
3. Insert the dampened cleaning disk in the drive.
4. Close the drive door.
5. If you are working in BASIC, reset the system (Ctrl-Alt, Del). With the cleaning disk inside the drive, the disk will simply spin, cleaning as it whirs along.
6. After 20 or 30 seconds, open the drive door, and remove the disk.
7. Turn off the computer.
8. Let the drive read/write head dry thoroughly before operating the system.

### To Clean the Drive Head Manually

Tools required: Flat-head screwdriver

Phillips screwdriver

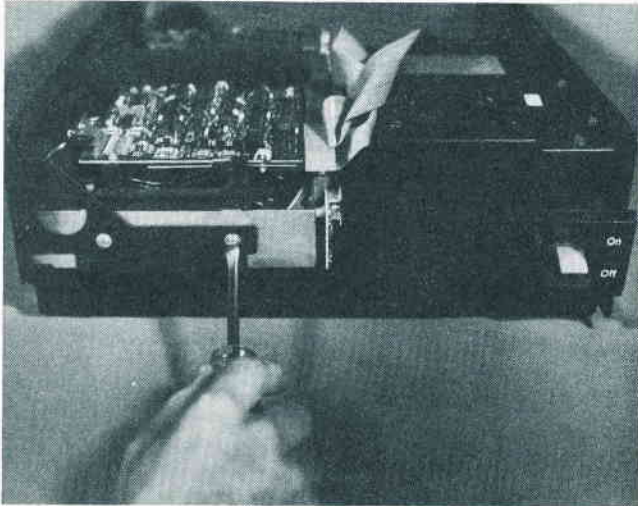
Protective pad

Adequate lighting

Tray to hold loose screws

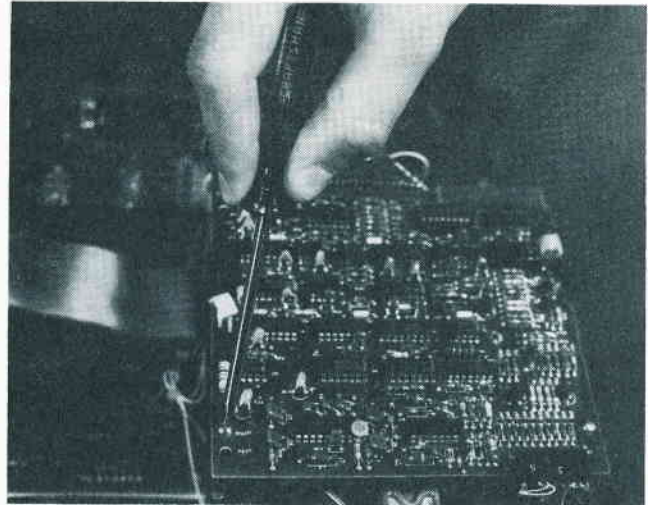
1. Turn off power to the computer.
2. Disassemble the computer using the procedures found in the Appendix.
3. Disconnect the disk drive cable from the back of the drive.

4. Remove the two silver flat-head screws holding the drive tight to the chassis as shown in Fig. 5-9.

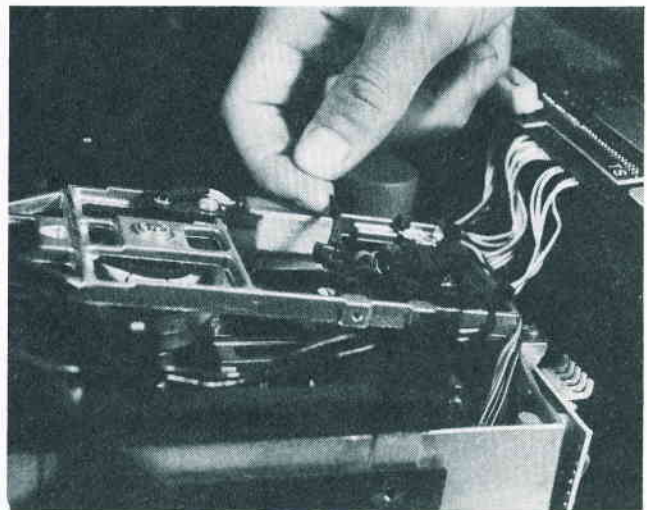


**Fig. 5-9.** Remove the two silver-colored flat-head screws holding the disk drive to the chassis.

5. Gently pull the drive forward approximately 2 inches from the front of the chassis.
6. Disconnect the power supply cable from back of the analog card.
7. Gently remove the drive from the chassis.
8. Carefully remove head cable(s) from the connector (located in the front right corner).
9. Carefully remove the two Phillips screws holding the analog card on the drive (located in the front on both sides) as shown in Fig. 5-10.
10. Slide the analog card toward the back of the drive until the card is free of the grooves in the drive mechanism. (You may have to wiggle the card gently to get it to slide.)
11. Lift up the analog card from the front.
12. Carefully lift the black head-load arm as shown in Fig. 5-11, and look for discoloration (build-up) on the surface of the pad, or on the read/write head below.
13. Using a special foam or wrapped cotton swab dampened with cleaning solvent, gently rub the head and the pad (refer to Fig. 5-8).
14. Let the surfaces dry completely before reassembling.



**Fig. 5-10.** Remove the two Phillips screws holding the analog card on the drive mechanism.



**Fig. 5-11.** Carefully lift the head load arm to expose the read head below.

15. When the head and pressure pad are dry, carefully slide the analog card back into the grooves in the drive mechanism.
16. Reinstall the two Phillips screws into the analog card (in the front on both sides.)
17. Reconnect the head cable(s), being very careful not to break or short connector pins.
18. Carefully push the drive mechanism back into the chassis until approximately 2 inches of the drive housing is still exposed.

19. Connect the power supply cable to the back underside of the analog card.
20. Push the drive all the way into the chassis housing.
21. Replace the two silver flat-head screws on the sides of the drive (refer to Fig. 5-9).
22. Reconnect the ribbon cable to the drive.
23. Power up the computer.
24. Place a copy of a program disk in the cleaned drive. (Have you waited until all the surfaces are dry?)
25. Close the drive door.
26. Load and run a program.
27. Reassemble the computer.
28. Restore the system to full operation.

**Note:** If you have any problems, refer to Chapter 4 in this book.

### Disk Drive Head-Cleaning Interval

Cleaning your drive head is like changing the oil in your car, which you do when you feel you've driven enough miles or when the oil looks dirty. Some software manufacturers recommend cleaning heads every other week. Some repair technicians say clean every 6 months. Others suggest you don't clean your heads until the disk drive makes mistakes trying to read or write data. Since no hard and fast rule has been offered, I defer to experience as shown in Table 5-5.

**Table 5-5. Disk drive head-cleaning interval**

System Usage	Cleaning Interval
Over 6 hours each day	Weekly
Daily	Monthly
Light to moderate	Twice monthly
Occasionally	Every 6 months

If you live in an area that gets a lot of smog, you may want to clean the heads more often. In any case, it won't hurt for you to clean at least annually. Keep an operational time log, so if you begin to get read/write errors, you can check it to see whether the drive head is due to be cleaned. Some recommended operational log sheets are included in the Appendix.

### Disk Speed Tests and Adjustments

Although this isn't mentioned by disk drive manufacturers as one of the PM operations you and I

could do, a somewhat more detailed, yet handy, process is adjusting the disk drive speed. Variation in speed is caused by normal mechanical drive wear or by excessive moving and reconnecting of the drives.

Just as automobile engines need periodic checkup and engine retuning, disk drives benefit from correctly adjusting the drive motor speed. Your IBM PC disk drives rotate at 300 rpm and work with soft-sectored disks; the computer software identifies the beginning and end of each of the sectors on each of the tracks. No timing holes are used, as they are with hard-sectored disks. This makes the speed of rotation critical to the accurate synchronization of the software with the signals stored on the disk. If the speed is off by only 10 rpm, the drive may not be able to correctly read the disk.

Should the speed be incorrect, the data will be written in the wrong location on the disk. The next time you access that area on the track again, the computer will hang up and give you a disk error. While disk speeds between 291 rpm and 309 rpm should be acceptable for read/write operation, speeds outside this range cause intermittent or disastrous results. If the speed becomes slower than 270 rpm or faster than 309 rpm, any write action will erase the synchronization timing marks on the disk, making the disk useless unless you reinitialize it (wiping out the data you had already stored).

There are two ways to tune up your drive speed. You can adjust the speed using a disk speed test program or a standard room lamp. Both techniques require your removing the disk cover.

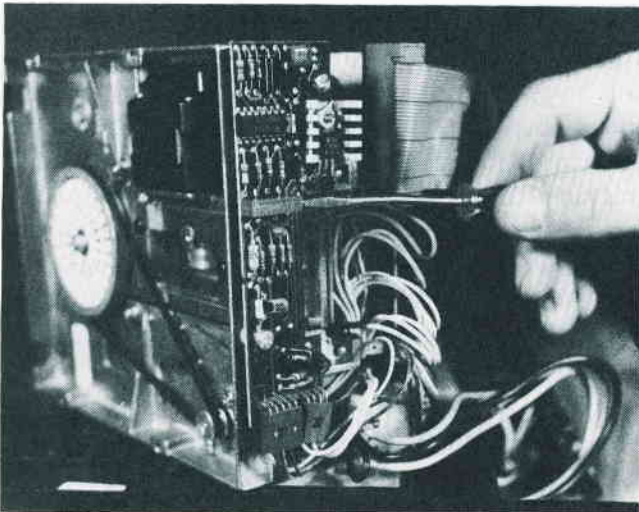
### Disk Drive Disassembly

- Tools Required:
- Phillips screwdriver
  - Flat-head screwdriver
  - Jeweler's flat-head screwdriver
  - Protective pad
  - Tray to hold loose screws

**Note:** If any of this seems difficult, have a repair service shop do the speed adjustment.

1. Turn power off to your computer.
2. Ground yourself to remove any electrostatic charge by touching a grounded surface, such as the metal switch on a nearby lamp.
3. Disassemble computer as shown in the Appendix.
4. Disconnect the drive cable from the rear of the drive.

5. Remove the two silver flat-head screws holding the drive tight (refer to Fig. 5-9).
6. Gently pull the drive forward approximately 2 inches out of the chassis.
7. Disconnect the power supply cable in the back of the analog card.
8. Pull the drive completely out of the chassis.
9. Set the drive mechanism on its side crossways on the top of the power supply.
10. Reconnect the drive cable and the power supply cable to the drive.
11. Locate the speed adjustment control potentiometer in the back middle of the drive as shown in Fig. 5-12.



**Fig. 5-12.** The screwdriver is inserted in the speed adjustment potentiometer (R23).

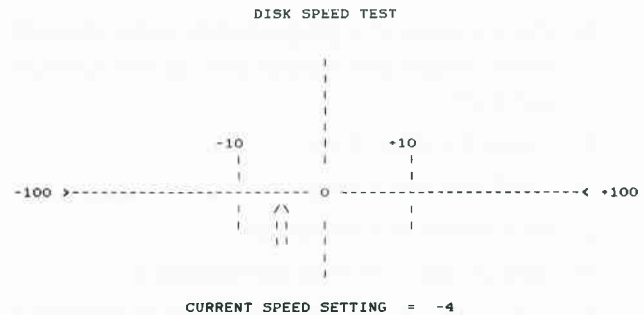
You are now ready to conduct drive speed adjustment.

#### Method 1—Disk Speed Program

1. Reconnect the power cord to the computer.
 

**Caution:** Be careful not to touch inside the drive mechanism or the electronics with power on.
2. Turn on the power to your computer.
3. Insert the disk containing a disk speed test program in the drive to be adjusted.
4. Close the disk drive door.
5. Boot the disk in the drive.
6. Follow the test procedures.

7. Most speed test programs display a graduated scale of some sort as shown by the example in Fig. 5-13. Using a jeweler's screwdriver or a "tweaker" (small screwdriver), slowly turn the speed control adjustment pot screw until the speed display shows the actual rotation time to be as close to 300 rpm as possible—within  $\pm 6$  milliseconds.



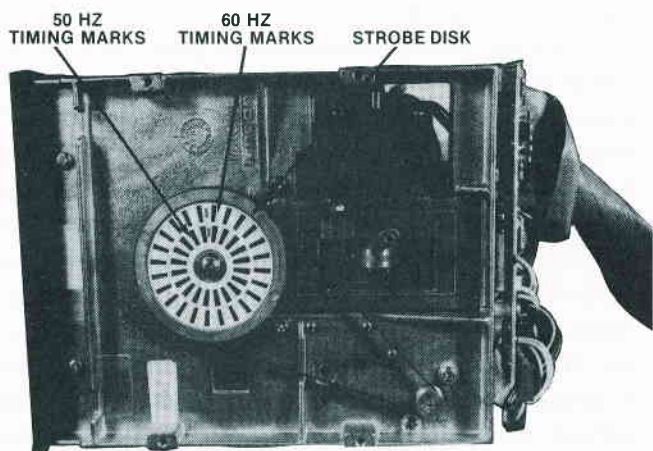
ESC(APE) TO STOP TEST

**Fig. 5-13.** Sample disk-speed test screen display.

8. Remove the disk.
9. Turn off the power to the IBM PC.
10. Disconnect the disk drive cable and power supply cable from the drive mechanism.
11. Push the drive mechanism into the front of the chassis until about 2 inches of the mechanism is left exposed.
12. Reconnect the power supply cable to the back of the analog card.
13. Push the drive all the way into the chassis.
14. Reinstall the two flat-head screws on the side of the drive.
15. Reconnect the disk drive cable to the drive.
16. Turn on the computer and test operate the drive.
17. Restore the system to full operation.

#### Method 2—Tuning Lamp

1. Disassemble the drive and set on its side as shown in Fig. 5-14.
2. Place a fluorescent light near the drive so it illuminates the speed strobe wheel on the bottom of the drive mechanism. An ordinary incandescent room lamp will work, but a fluorescent light is easier to use.



**Fig. 5-14.** The disk drive set on its side with the strobe wheel facing you.

3. Locate the timing marks on the strobe disk (see Fig. 5-14). The outer circle of markings is used for 60 Hz electrical systems such as that common in the United States. The inner circle of strobe markings is used with 50 Hz line power such as that found in Europe. This concept of speed adjustment is amazingly simple, and quite accurate. When you place the strobe disk in the light of a fluorescent lamp and cause the disk to spin, you will notice that the strobe disk marks slowly rotate in one direction or another, depending on whether the disk speed is fast or slow. This action is much like the effect seen with movie film when stagecoach wheels seem to be rotating in the direction opposite the movement of the coach. The wheels are rotating at a different speed than the film is moving through the projector so you see this strange effect. The marks on the strobe disk are spaced so they appear stationary when the speed is exactly 300 rpm.
4. With a lighted lamp near the drive, reconnect the disk interface cable to your computer.
5. Reconnect the power supply cable to the drive in back of the analog card.
6. Power up your computer.
7. Insert a blank, uninitialized disk in the drive and close the drive door.
8. After the computer goes into BASIC, reset the system (Ctrl-Alt, Del).
9. Observe the strobe wheel as the disk spins in the drive.
10. Using a jeweler's screwdriver or a "tweaker" (small screwdriver), adjust the speed control pot until the strobe disk seems to be sitting still.
11. Open the drive door and remove the disk.
12. Turn off the computer power.
13. Disconnect the disk drive cable from your drive.
14. Disconnect the power supply cable from the back of the drive.
15. Gently push the drive mechanism into the front of the chassis until about 2 inches of the drive remains exposed.
16. Connect the power supply cable to the back of the drive analog card.
17. Gently push the drive mechanism all the way into the chassis.
18. Reinstall the two screws holding the drive into the chassis.
19. Reconnect the drive cable to the IBM PC drive.
20. Turn on the computer and test operate the drive.
21. Restore the system to full operation.

### Disk Drive Alignment

This procedure is not recommended for the novice. The alignment adjustments in the IBM drives set the positioning of the read/write head correctly over the tracks on the disk, adjust the disk stop guide, or adjust the collet hub that fits in the hole in your disks. These procedures require special equipment, including a dual-trace oscilloscope, special alignment disks, and various disk alignment tools usually available only to IBM repair technicians. If speed adjustment and cleaning don't clear up any read/write problems you may have had, take your drive into a service center for maintenance.

The most critical alignment adjustment is adjustment of the read/write head alignment, or tracking. Some programs require very accurate alignment of the head over the track. If the program loads fine but won't read data and the disk just spins, you may have a track alignment problem.

If you have to replace the electronics analog card in the drive, you should have the tracking checked. Each card is tuned for the drive, and a new card could affect the head tracking.

Alignment should be checked every year. The easiest way to accomplish this is to format two disks on two different drives whose speeds have been verified to be correct. Save some programs on each disk, using the same drive on which formatting was done. Read and write each disk with its own drive to make sure the individual drives work satisfactorily. Then switch disks and see if each disk works properly in the alternate drive. If one drive reads correctly while the other can't find the data or reads out "garbage," you know you have alignment problems.

## Hard Disk Maintenance

Since hard disks are sealed in dust-tight enclosures, the only PM you can do on these devices is exterior cleaning and proper location to minimize noise interference problems. Improperly connecting peripheral interface cables has been known to generate so much RFI that some hard disk units over 6 feet away have failed to operate correctly.

## USING HEAT TO SPOT POTENTIAL TROUBLES

There are two techniques you can use that employ heat detection to diagnose failing components inside your PC before they fail completely.

### Thermal Imaging

A new troubleshooting and preventive maintenance technique uses the temperature of the components to determine the condition of the system much as a mother takes the temperature of her child to see if the child is ill. This technique is called *thermal imaging*, or *thermography*, and is proving to be a remarkably accurate preventive maintenance tool.

Imagine having an infrared picture taken of your personal computer system board, new and shiny, and operating on a certain program. Comparing this to a second photo taken a year later, when the system has started acting "flaky," shows you a new "hot spot" right in the middle of the board's RAM indicating that one of the memory chips is about to give out. Replacing this one chip will bring the system back up to peak operating potential.

Standard photography produces images or pictures from visible light; thermal imaging produces pictures from the invisible heat coming up off the surface of objects. It's a cost-effective maintenance procedure in many large industrial plants.

Several companies sell expensive thermograph machines that produce heat images, or "heat maps," in vivid color on high-resolution red-green-blue (RGB) monitors. These units can measure temperatures all over a printed-circuit board with a sensitivity of 0.1° C over a temperature range of 0–200 degrees. If any board has an area on it with a temperature outside specific limits, a computer comparison of the suspected board temperature image with normal board baseline temperatures will immediately point out the fault. Faults can be shorts, opens, and even marginally defective components. These thermograph units can even diagnose failures in high-density circuit boards—all without touching the board. Unfortunately, these machines cost thousands of dollars. But there's an alternative.

If you own a 35mm camera, you could try your own thermal imaging using infrared (IR), heat-sensitive film. Either color or black and white should work. A good black-and-white candidate is Kodak HIE-135-36, ASA-25 IR film. Color IR film is about 50 percent more expensive. A special filter (Wratten number 87, 88A, or 89B) makes the picture more effective.

With the PC open, and running a simple program that continuously repeats, let the computer warm up for about 2 minutes so that the components reach their usual operating temperatures. Then take a picture of the motherboard. Background light won't matter, because the film is sensitive to heat, not light. Take several shots.

Then periodically, every 6 months for example, or when the system starts acting up, take another series of pictures with the same program running in the computer. A comparison of the before and after pictures will quite likely point out where your system is wearing out or has failed already.

### Heat-Sensitive Liquid Crystal

Another useful technique for finding potential or actual troublespots in your computer is the use of *liquid crystals* (LCs). These organic compounds, derived from cholesterol, react to changes in temperatures by changing color. They provide a visual method for testing and evaluating the IBM PC circuit boards.

Liquid crystal is available as a laminated (pressed layer) film or as a liquid solution. The liquid solution is recommended for circuit boards. The temperature range for measurement can be specified in increments of 1 to 50° C within an operating range up to 150° C.

Two types of these liquid crystals are available today—the *temperature-limited liquid crystal* (TL-LC),

which returns to its original shade upon cooling, and the *recording temperature limit liquid crystal* (RTL-LC), which remains an ash-gray color until you brush or rub it, causing the original shade to return.

The nondrying opaque liquid is applied by brushing it directly on the surface of solder joints, chips, other circuit board components, and connectors. The solution has a very high resistance, so it won't short out anything on the board.

When the PC is energized, the heat generated as the circuits function causes the liquid crystal solution to change color according to the temperature sensed by the solution. Hot spots turn indigo blue, cooling to blue, turquoise, green, through yellow and orange, to red and finally gray.

This LC solution is useful for testing printed-circuit components for failing chips, solder shorts, and even solder connection bonds that are breaking apart. The completeness of a bond can be detected by the color changes during normal operation; air in the bond cools more slowly than the surrounding metal. A dark surface shows the color changes best so the manufacturer adds black dye to the LC solution.

Typically the surface to be tested is first cleaned of all oils and dirt, since these contaminants will give incorrect color readings. Then it is dried, and the LC solution is brushed or sprayed onto the components and board, leaving a thin, even coat. When the circuit is powered up, the rainbows of colors pinpoint the hot spots on the board or components. If the heat generated at one place on the board doesn't follow the normal circuit heat-up pattern, a failure in that component area can be predicted. Excessive heat generation from connectors indicates a poor connection.

When the test is complete, the solution can be wiped off with a lint-free cloth. The solution won't short out or contaminate the circuit board or the components.

A testing kit including sheets of film, different temperature-range liquid solutions, an aerosol can of black paint, applicator brushes, a sprayer, and solvent for surface and sprayer cleaning is available from Liquid Crystal Applications, Inc. in Clark, New Jersey for about \$250.

## DISPLAY SCREENS AND HEALTH PROBLEMS

This subject has been bantered about for 15 years as hobbyists, military and civilian radar operators, and, currently, word processing operators struggle for answers to some nagging questions. Will long periods of staring at the face of a CRT screen damage the eyes?

Is the radiation emitted by the CRT tube dangerous to the user? Let's take these questions in reverse order.

### CRT Radiation

A CRT that makes characters and shapes on its screen by sending streams of electrons toward a phosphor-coated surface (the back or inside of the screen) does produce radiation. Two types of radiation are produced. Light radiation, which becomes the characters we look at, and low-level x-radiation.

The U.S. government has placed limits on the amount of x-radiation that can be allowed to escape from the face of a CRT. This limit is 0.5 milliroentgens per hour, measured about 2 inches out from the screen. Manufacturers of CRTs added strontium and lead to the glass panels in televisions and monitors to eliminate almost all escape of x-radiation. Many intense tests were conducted by government and civilian organizations to determine how much radiation is emitted by video display terminals. The results were very encouraging. There was no evidence of damaging radiation coming out of any of the displays tested. Measuring instruments recorded more radiation in the sunlight than in the CRT display light. The overwhelming conclusion of these researchers is that radiation from video displays doesn't threaten our vision.

### Eyestrain and Neck and Back Strains

Eyestrain and neck and back strains can be related to how we use our computer systems. Eyestrain can also be caused by what type display we use. Older screens display harsh white letters. Looking at a high-contrast screen of letters and numbers for a long time can cause eye fatigue, headaches, and neck and back strain. The development of new CRT phosphors has made green and now amber displays possible, significantly reducing eyestrain problems.

Room light reflections were also linked to eyestrain. Display terminal users should work in a well-lighted room and use nonreflective surfaces on their CRT display screens.

There is a feeling among some optometrists that many computer operators do not naturally point both eyes so the eyes focus on the screen surface. Their eyes actually point (converge) a few inches in front of, or behind, the screen. The brain compensates for this and makes the eye muscles work to focus the eyes at the screen. Since this is an unnatural condition for the eye muscles, strain occurs and can cause headaches. Special glasses for computer use can correct this problem.

Eyestrain can also occur when you set your display monitor to one side of your keyboard so that you view the screen at a slight angle. The distance from eye to screen is slightly different for each eye, causing the eyes to focus separately. This places strain on eye muscles. If the user works for an extended period of time in this position, the eye muscles become fatigued. You can also get neck and back strain from working like this. It's best to position the CRT so that you look straight ahead to view the display screen.

Neck and back strain, and even some emotional problems, have been related to long periods of using a display screen. These issues are being resolved by redesigning the operator station, the desk, or even the room itself. Poorly designed desks and poor working environments affect the quality of the work done by display terminal operators. In addition, managers sometimes fail to apply good work practices for people "stuck" on a console for hours on end. Since most managers use computer screens a limited part of each day, they don't appreciate the problems that full-time computer operators experience. This may explain why many managers don't understand how display screens affect workers and why they may be unsympathetic to complaints.

To solve workers' problems, new displays are being designed and work concepts are being revised. There are more display monitors that can tilt and swivel to improve user comfort. More computers are being introduced with detachable keyboards. Monitor height positions are becoming adjustable. Glare-reducing screens have become standard in new displays. Room lighting is being redesigned for optimum display-screen viewing. Work conditions are being modified to include frequent rest breaks, training classes are being conducted to educate management and employees in the proper use of video terminals, and company-provided computer-use glasses are being offered. Business has made great strides in reducing user problems.

You can learn from the long-term experiences of computer users and act to reduce the probability of your own eyestrain or neck or back strain:

- Use a hard-back chair instead of a soft, "cushy," slouch-inducing recliner.
- Look straight ahead at the screen (line of sight perpendicular to screen).
- Take frequent, short rest breaks.
- Take a moment to stretch. Develop some simple physical exercises to move unused muscles.
- Move away from your computer system for a few minutes each hour. This gives the eyes a rest and can often clear the brain for the arrival of another great idea.
- Keep the room well lighted but not harshly bright. Try a desk lamp with an incandescent bulb shining on your work and keyboard area from the side. You can also keep an overhead light on for background lighting and to cut glare.
- Set your display unit at a height that feels comfortable for viewing. You'll know if it's correct after a few hours at the keyboard. Adjust the display height as necessary.
- Have your eyes examined at least annually (every 6 months is better). If you wear glasses, the doctor can prescribe lightly tinted lenses (light blue or light green), which help to reduce eyestrain.
- Increase your intake of foods high in vitamin A (carrots and squash, for example—the "yellow" foods).
- Keep your equipment clean and in good operating condition.

There are over 10 million video display units in use today, and twice this many are expected to be in use within 2 years. As prices come down, perhaps it's time to consider trading in that old, clunky black-and-white display for a new \$100 green or amber unit that will serve you better.

## SUMMARY

This chapter has covered aspects of routine preventive maintenance that can be used to keep the IBM PC system in peak operating condition. It discussed six major contributors to computer system failures: excessive temperature, dust build-up, noise interference, power-line problems, corrosion, and magnetic fields. For each of these factors, one or more preventive countermeasures was presented. You learned that floppy disks are uniquely constructed to be protected from dust and dirt, discovered how disks and disk drive read heads can be damaged, and, most important, learned how to extend the life of disks and disk drive systems. You also learned two interesting ways to use heat for locating potential or existing circuit failures. Finally, you learned that display-screen-caused eye, neck, and back problems can be prevented.

# Advanced Troubleshooting Techniques

---

*In Chapter 6 you will learn advanced troubleshooting techniques. You'll be introduced to the repair technician's "tools of the trade." Like other parts of this guide, Chapter 6 is full of "meat and potatoes" information to help you keep your PC system in peak operating condition.*

In earlier chapters you learned the basic techniques for troubleshooting most IBM PC failures. You learned how to recognize the various components of your computer, and you discovered three ways to find failures.

- The hardware approach
- The software approach
- The IBM-Easy approach

In the **hardware approach**, you use troubleshooting tools such as logic probes and logic pulsers to step through a circuit. This requires test equipment and some knowledge of digital electronics.

The **software approach** is a troubleshooting method used widely by IBM PC repair technicians. As long as the disk drive boots up properly, diagnostic software is effective at finding chip failures.

The **IBM-Easy approach** is to use the troubleshoot-

ing guides in Chapter 4 to quickly pinpoint what might be chip failures. If you conclude that the problem is not a chip and you still want to locate the failed part, you can use the techniques discussed in this chapter to test the rest of the components in the suspected failure area.

## TOOLS OF THE TRADE

When the problem can't be solved using flowcharts and pictures, repair technicians reach for help—they reach for their "tools." These tools are not only the tiny screwdrivers (tweakers), the diagonal cutters (dykes), and the soldering pencil. They also include electronic test equipment—various meters (VOM, DVM, DMM), logic probes, logic pulsers, current tracers, clips, oscilloscopes, and logic and signature analyzers.

### Meters

Electronic measurement equipment has improved a great deal over the years, markedly improving your ability to test and to locate circuit troubles. Twenty years ago, a meter called a VOM (volt-ohm-milliammeter) was used to measure the three parameters of an electric cir-

cuit—voltage, resistance, and current (Fig. 6-1A). Then came the VTVM (vacuum-tube-voltmeter). It wasn't long before electric circuits made room for electronic circuits. Digital circuits replaced analog circuits in many applications, and new meters appeared for troubleshooting, using some of the new digital capability in their design. The DVM (digital voltmeter) and DMM (digital multimeter) (Fig. 6-1B) quickly became the preferred measurement devices for many technicians because they offered capabilities better suited for electronic circuit testing, including increased accuracy. These meters have characteristically high input impedances (resistances), so they don't load down or draw down a digital circuit, in which the voltages and currents are far lower than those found in analog circuits.

Two kinds of changes affected the types of tools used in troubleshooting and repair. First, vacuum tubes were replaced by solid-state devices such as transistors and the integrated circuit (IC), or chip. Second, circuits themselves became smaller, with more components packed compactly into less board area. One needs only compare the early radios and televisions (standing 4 feet tall and weighing 40 pounds) with the wrist radios

and now the wrist televisions of today to recognize that electronic circuits are smaller, more complex, and more difficult for test-probe access.

Electronic advances always lead to electronic opportunities, and clever test equipment designers soon came up with devices that allowed digital circuit testing without fear of inaccurate readings caused by circuit overload, or circuit failure caused by bulky test



A. Volt-ohm-milliammeter (VOM);



B. Digital multimeter (DMM).

Fig. 6-1. Two types of meters commonly used in troubleshooting.

probes shorting two pins or wires on a packed printed-circuit board.

### The Logic Clip

The logic clip, a digital circuit testing device, is shown in Fig. 6-2. This handy tool fits over an IC and has exposed pins at the top. Measuring or monitoring probes or tiny clips can be attached to the pins to determine the logic level on any pin of the device under test.

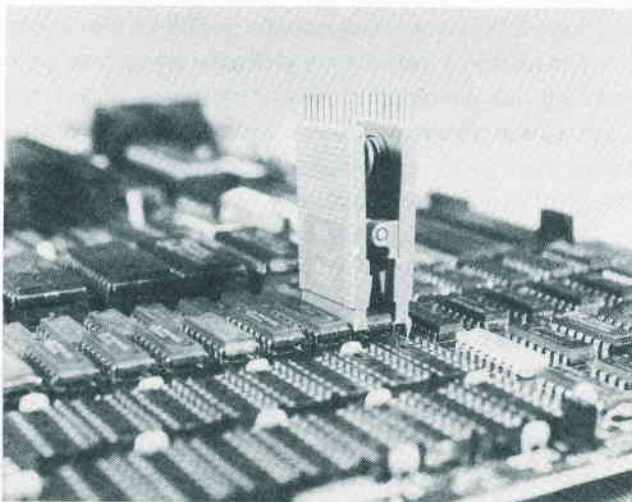
Another type of logic clip has a built-in monitoring capability (Fig. 6-3). Instead of exposed pins, the top of the clip is lined with two rows of light-emitting diodes (LEDs), which continuously display the logic condition of each pin on the chip. The LEDs are turned on (indicating a logic 1) by power from the circuit under test. All the pins are electrically buffered so the clip doesn't load down the circuit being tested.

**Caution:** When using a logic clip, turn power to the circuit off, attach the clip, and then turn power on. (This helps prevent accidentally shorting out the chip.)

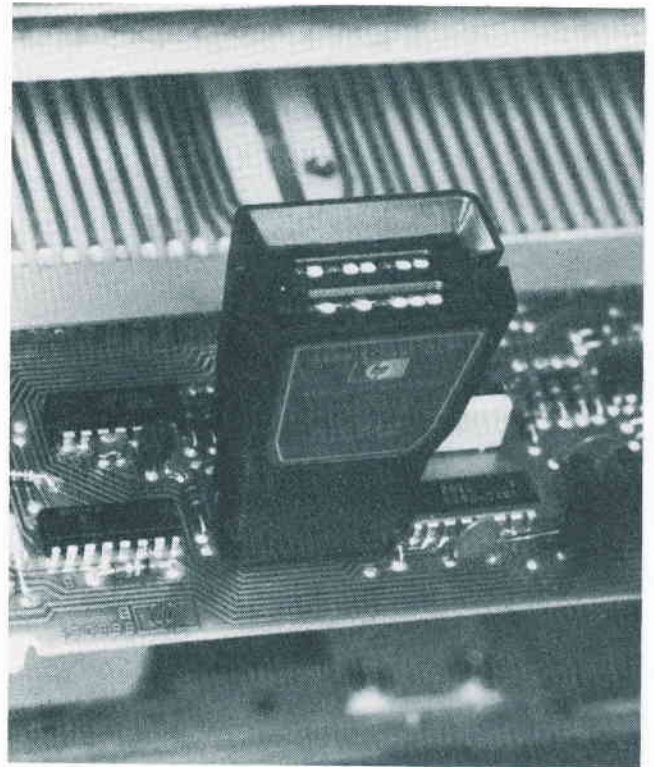
Logic clips can be obtained in several varieties—to work with almost all logic families, including TTL and CMOS—and in voltages up to 30 volts DC.

To use the clip, squeeze the top (LED) end to spread the pin contacts, and slip the clip over the top of the chip to be tested. When power is applied to the circuit, the LEDs will indicate the logic level at each pin on the chip.

Logic clips can be used on ICs with up to 16 pins, or 80 percent of the ICs on your IBM PC system board.



**Fig. 6-2.** A popular type of logic clip. (Pomona Electronics Division of International Telephone and Telegraph Corporation)



**Fig. 6-3.** This logic clip gives visual indication of the logic condition at each pin. (Hewlett-Packard)

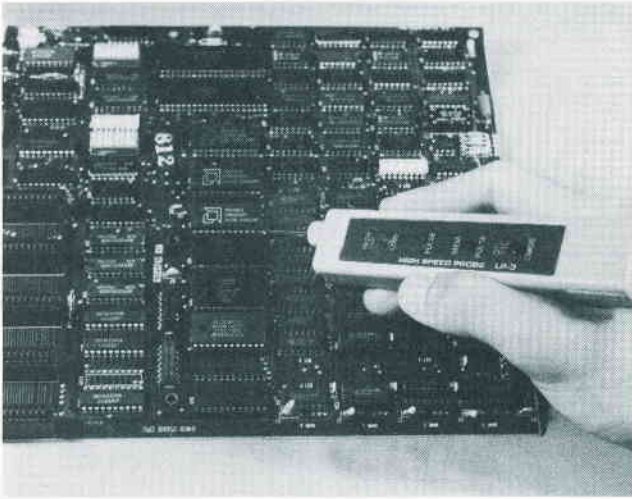
### The Logic Probe

When you want to really “get into” your circuit, you can use a logic probe. A blown chip can't be repaired, but the logic probe can tell you which chip has failed so you can replace it.

The logic probe shown in Fig. 6-4 is the most widely used tool for this kind of analysis. It can't do many of the things complex test equipment such as logic analyzers can do. However, the high frequency of chip failures in electronic circuits, the simplicity of the probe, and the ability to rapidly troubleshoot in an energized circuit make this tool ideal for 90 percent of your fault-isolation needs.

When the tiny tip of the probe is placed against a pin on a suspected bad chip, a test point, or even a trace on a circuit board, an indicator light near the tip of the probe tells you the logic state (level) at that point. The metal tip on most logic probes sold today is protected against damage from accidentally touching a source of higher voltage (up to 120 volts AC for 30 seconds) than that of logic gates (+5 volts).

Some probes have two lights built in near their tip—one for logic HIGH and the other for logic LOW. The better probes can also tell you whether the test



**Fig. 6-4.** The logic probe is the most widely used tool for circuit-board analysis.

point has a pulsing signal present. They can also store a short pulse burst to tell you if a glitch or spike has occurred at that point. If you're planning to buy a logic probe, be sure it will work with the logic families of the chips you plan to analyze.

The ability to touch a point with the probe tip and directly determine the condition at that point for diagnostic analysis, and the ability to store pulses make this device easy to use and universally accepted as the proper diagnostic tool for all but the most complex digital troubleshooting. Other tools force you to attach the measurement probe and then look away at some display to read the condition. The logic probe displays the condition near the tip of the probe itself.

The logic probe in Fig. 6-4 provides four indications:

- Lamp OFF for logic LOW (logic 0)
- Lamp ON bright for logic HIGH (logic 1)
- Lamp DIM for floating or tri-state
- Lamp flashing for pulsing signals

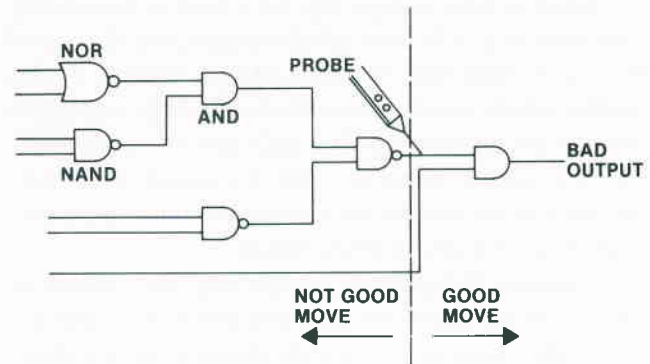
Power for the probe comes from a clip attached to a voltage point on the circuit under test. Another clip attaches to ground, providing improved sensitivity and noise immunity.

Probes are ideal for finding short-duration, low-frequency pulses difficult to see on an oscilloscope, but more often they're used to quickly locate gates whose output is hung, or locked, in a HIGH or LOW condition.

A useful method of circuit analysis with the probe is

to start at the center of the suspected circuit and check for the presence of a signal. (This of course assumes you have and can use a schematic of the circuit.) Move backward or forward toward the failed output as shown in Fig. 6-5. It doesn't take long to find the faulty chip whose output isn't changing.

The only limitation of logic probes is their inability to monitor more than one line.



**Fig. 6-5.** Circuit analysis starting at the center of a suspected circuit.

## The Logic Pulser

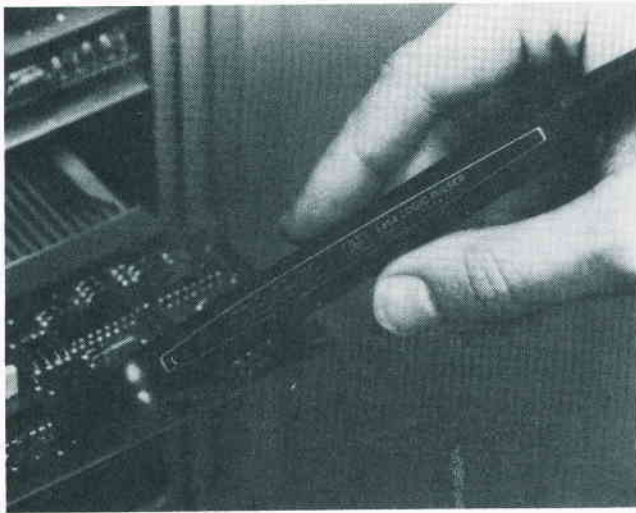
If the circuit under test doesn't have a pulsing or changing signal, you can inject controlled pulses into the circuit using a logic pulser (Fig. 6-6). These handy devices are portable logic generators.

When activated by a pushbutton or slide switch, the pulser will sense the logic level at the point touched by the tip and automatically generate a pulse or series of pulses of the opposite logic level. The pulses can be seen on an LED lamp built into the handle of the pulser.

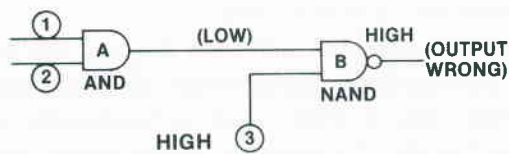
The ability to introduce a changing signal into a circuit without unsoldering or cutting wires makes the logic pulser an ideal companion to the logic probe. These two tools used together permit step-by-step stimulus/response evaluation of sections of a circuit.

Fig. 6-7 shows several ways to test logic gates using the probe and pulser. Assume the output of the NAND gate remains HIGH. Testing inputs 1, 2, and 3, you find them all HIGH. This condition should cause the AND gate output to go HIGH, producing a LOW out of the NAND gate. Something is wrong. Placing a probe at the AND gate output, you discover the level is LOW. It should be HIGH. Now, which gate is bad?

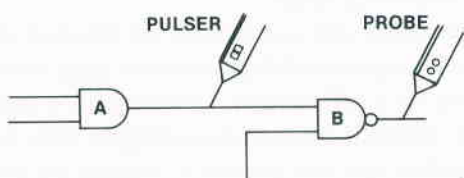
To find out, place the probe on the NAND (gate B) output and the pulser on the AND (gate A) output (NAND gate input) as shown in Fig. 6-8. Pulse this line.



**Fig. 6-6.** A logic pulser can be used to inject a signal into a circuit.



**Fig. 6-7.** There are several ways to test logic gates like these.

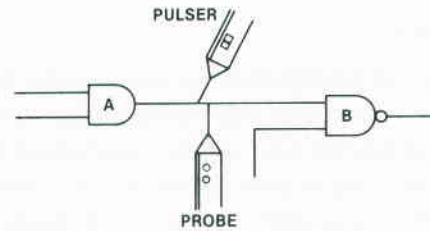


**Fig. 6-8.** Place the probe on the NAND gate output and the pulser on the AND gate output.

The probe should blink, indicating a change at the input to the NAND. If it doesn't blink a change, the NAND may be bad. But what if the LOW was caused by a short to ground at the AND output or the NAND input?

Place both the probe and the pulser on the AND output trace as shown in Fig. 6-9, and pulse this line. If the probe blinks, the NAND is bad; its input changed state, so its output should have changed state also.

If the probe doesn't blink, you know this line is shorted to ground. One way you can determine which chip is shorted is by touching the chip case. A shorted chip gets pretty hot, while a chip hung at one level seems to be normal but just won't change state.



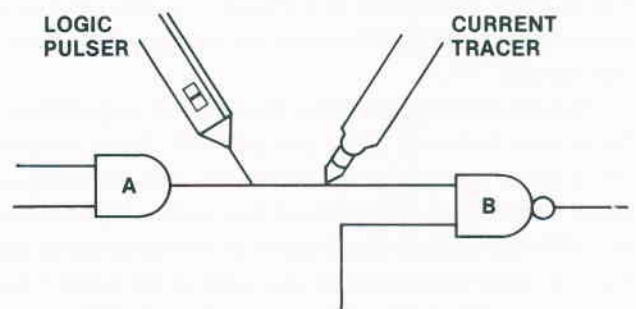
**Fig. 6-9.** Place the probe and the pulser on the AND gate output.

### The Current Tracer

A fourth handy troubleshooting aid is the current tracer probe. This portable device lets you precisely locate shorts on your computer's motherboard (or on a peripheral card). The current tracer senses the magnetic field produced by the flow of electrical current in the circuitry. The logic pulser can be used to generate a pulsing signal that will make the current tracer LED blink, indicating the presence of current.

If you set the tip of the tracer on a printed circuit line and slide the tracer along the line, an LED in the tip end of the tracer will pulse as long as there is a current present. When you slide past a shorted point, the lamp will dim or go out, and you've found the short.

Fig. 6-10 shows an easy way to determine which gate has the short to ground in a logic circuit. Assume gate B has a shorted input. Place the pulser and the tracer midway between the two gates. Adjust the LED in the current tracer so that it just lights. Pulse the line as you place the tracer on the output of A and then on the input to B. The gate with the short to ground will pulse brightly because most of the current is going to ground here. Therefore, if the input to B is shorted, it causes the tracer lamp to pulse brightly, while the A side of the line doesn't cause the LED to light.



**Fig. 6-10.** Following the LED light with your tracer will lead you to the short.

## IC Testers

Advanced troubleshooting equipment is becoming very sophisticated (and expensive). Today, for between \$1,000 and \$2,000, you can buy equipment that tests almost every chip in your system. For \$10,000 you can even conduct your tests from a remote location.

Micro Sciences, Inc. in Dallas, Texas makes an IC tester that can test over 100 7400 TTL and 4000 CMOS series devices. Options for this tester include RAM and ROM tests.

Microtek Lab in Gardena, California makes a tester that can do complete functional pin tests of all 900 devices in the 54/74 TTL series chips. This test tool displays the condition of the chip under test on a liquid crystal display (LCD). It uses LEDs to signal GO/NO GO test results.

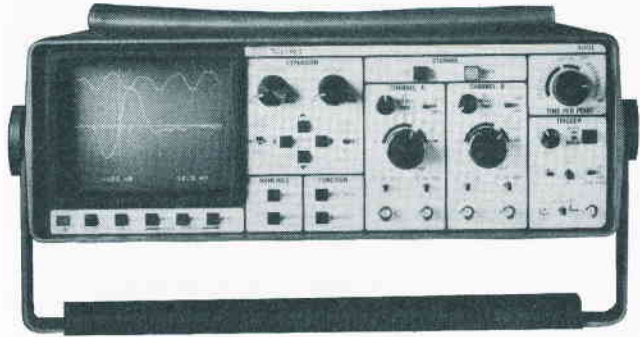
VuData Corporation in San Diego, California markets an in-circuit component tester that's actually a 50 MHz CRT to display the voltage-versus-current characteristics for virtually all circuit components, including capacitors, diodes, integrated circuits, resistors, and transistors. With this tester, the shape displayed on the CRT indicates the condition of the component under test. Using this test machine, you can easily pick out open circuits, shorts, leaky diodes, leaky transistors, and marginal ICs. The tool is valuable because it can test a wide selection of components while they're still mounted in the circuit.

## The Oscilloscope

The oscilloscope has been with us for years, although recent advances in the state of the art have added a great many capabilities to the instrument.

Simply put, an oscilloscope (Fig. 6-11) is an electronic display device that draws a graph of signal voltage amplitude versus time or frequency on a CRT screen. A scope is used to analyze the quality and characteristic of an electronic signal sensed by a probe that touches a test point in a circuit. It is also used as a measuring device to determine the voltage level of certain signals.

Scopes come in all sizes, shapes, and capabilities. Prices vary between \$500 and \$20,000. Some scopes use a single test probe for displaying and analyzing a single trace signal. Others have two probes and display two different signals (dual trace) at the same time. As many as eight traces can be analyzed at the same time on some oscilloscopes. The November 17, 1983 issue of *Electronic Products* magazine described the newest in oscilloscope technology, a seven-color digital scope



**Fig. 6-11.** A digital oscilloscope.  
(Nicolet Oscilloscope Division)

from Test & Measurement Systems Company. Colors make it possible to compare signals at different locations in the circuitry very rapidly. Some scopes even have built-in memories to let the machine store a signal of interest for future evaluation.

Besides sensitivity and trace display, one of the major distinguishing characteristics of oscilloscopes is that they allow a great range of frequencies to be observed on the CRT screen as frozen images. We call the range of frequencies *bandwidth*. Bandwidths vary between 5 MHz and 300 MHz, and price is proportional to frequency range.

Oscilloscopes are useful tools for freezing an analog or varying signal and displaying this static waveform on the face of a CRT screen covered with a measurement grid. While it is time consuming to learn how to use an oscilloscope, the analytical rewards are substantial. Not only can you measure voltage amplitudes and frequencies of test signals, you can also measure delay times and signal rise and fall times, and even locate the intermittent glitch.

If you're not trying to set the world on fire as a system designer, you can probably get along fine with a dual-trace, 25–30 MHz scope. Investment in an oscilloscope is not cost effective if you intend to use it only for analyzing your PC system board during troubleshooting a component failure. You'd be better off saving the money and spending a comparatively small portion of it to have a service center fix your machine.

The nice thing about dual-trace, quad-trace, and even eight-trace capability is the ability to look at different signal paths or different signals simultaneously. For example, you could look at the input and output of a gate and actually see and be able to measure the delay time for the signal passing from input to output of

the chip. Another useful technique is simultaneously displaying all or parts of the data bus or part of the address bus to see what the logic level (HIGH = +5 V, LOW = 0 V) is and what binary number it represents.

## Logic Analyzers

The logic analyzer is a multichannel oscilloscope with a memory. It captures and stores a number of digital signals, letting you view the signals simultaneously. If each signal is a bit on the data bus, you can see the entire data bus at one time. This means you can analyze the logic level for each bit on the bus for any instant in time. The bus signals are frozen for your display and analysis. The ability to freeze a single event or data pattern so you can determine the information present on a digital bus at any moment is a distinct advantage for troubleshooting.

Logic analyzers, like oscilloscopes, cost between \$500 and \$20,000. And, again like the scopes, logic analyzers come in a range of bandwidths, between 2 MHz and 200 MHz.

These analyzers can display many signals (channels of input) simultaneously. Arium Corporation in Anaheim, California recently announced an analyzer that handles 32 channels of input data at frequencies up to 100 MHz. Nicolet offers a 48-channel, 200 MHz analyzer with built-in microcomputer and dual, double-density floppy disk drives. Each channel has associated with it a probe clip for connecting to some test point in the circuitry. The clip probes are tiny and easy to install.

A sampling of the capabilities currently available in logic analyzers reveals one configuration that provides 104 channels at 25 MHz, another with 32 channels at 100 MHz, and yet another with 16 channels at 330 MHz. Another configuration has 8 channels of input and can operate at 600 MHz! (Recall that your IBM PC clock is 4.77 MHz.)

Where would logic analyzers be useful? One place is in debugging software. You can read the data in machine code and trace its flow through the circuit. You could analyze the input and output of memory simultaneously for locating a bad RAM chip. Or you could uncover intermittent glitches, those phantom spikes that can cause havoc in your system. There are many more uses for logic analyzers, including analysis of disk I/O operation.

The logic analyzer has been called the oscilloscope of the digital domain. It can be a valuable tool for the software or hardware designer. But for the home or small business computer owner who simply wants to

fix his or her own computer when it fails, the logic analyzer is expensive overkill.

## The Signature Analyzer

Logic probes can be effective in detecting logic levels and pulses at single points. Oscilloscopes can extend the number of points to be monitored even though the data pulses all tend to look alike. And logic analyzers extend the number of test points even further to include buses the size of the data and address buses. However, as the sophistication and capability of the measurement device increases, so does the expertise required to operate the test tool. Logic analyzers, in particular, can be very capable but they can also be difficult to understand and operate. The signature analyzer was developed to allow easy detection of hardware failures.

Signature analysis is a comparison method of troubleshooting. It works by running a diagnostic program in the system being tested and evaluating a coded signal at specific test points in the circuitry. If the coded signal matches the code observed when the system was running properly, the malfunction is not in that part of the circuitry. When a test point signature fails to match the baseline correct code, this indicates that you have located the faulty area. Then you can probe backward or forward from this point to locate the component that has failed.

The key to the success of this test technique is in the signature code. The first codes were developed by Hewlett-Packard and with slight modification are still being used today. A test code is a 16- or 24-bit repeatable value that represents a stream of data passing a test point during an interval of time. This known stream of data, when sampled at different places on a good circuit board by a signature analyzer, produces a unique 16- or 24-bit code at each test point.

These codes can be documented or stored in a programmable read-only memory (PROM) and recalled later for comparison during troubleshooting. The PROM then becomes a custom memory module containing every signature sampled from a properly working system that was being stimulated or pulsed with a known data stream.

Signature analysis has not been a popular troubleshooting tool because it takes lots of time to identify the test points, or nodes, probe the nodes, produce a signature, and then document the code. Once this task is completed, however, the task of locating a failure becomes easy. And the introduction of PROM modules has made the setup task much easier.

More improvements in this analysis technique can be expected in the near future. One analyzer already on the market uses a mode called “backtrace” to prompt the troubleshooter through a series of test points, guiding the tester to trace bad signatures back to the failed part.

The investment for a signature analyzer is between \$400 and \$10,000. Signature analysis uses a simple, nontechnical approach to troubleshooting, so even untrained people can use the equipment and the technique.

## COMPONENTS AND HOW THEY FAIL

While the use of troubleshooting equipment makes the analysis and isolation of computer problems much easier, many failures can be found without expensive equipment. In fact, an understanding of how electronic components fail can make troubleshooting and repair relatively simple.

Now that you understand what kinds of tools are available, let’s look at the kinds of components you’ll be analyzing in your troubleshooting efforts and how these components can fail. Other than those that result from operator error, failures generally occur in the circuits that are used or stressed the most. These include the RAM and ROM chips, the 8088 CPU, and the I/O chips between the motherboard and the disk drive. The CPU is a highly reliable device and doesn’t fail very often. Most failures involve the other chips. Except for the ROMs, which are preprogrammed by IBM, these other chips are standard off-the-shelf devices and are so common they’re called “plain vanillas” or “jelly beans”—inexpensive easy-to-replace products. There are other components on your computer’s motherboard that may someday require replacement. These require soldering and are not as easy to replace.

### Integrated Circuits—Chips

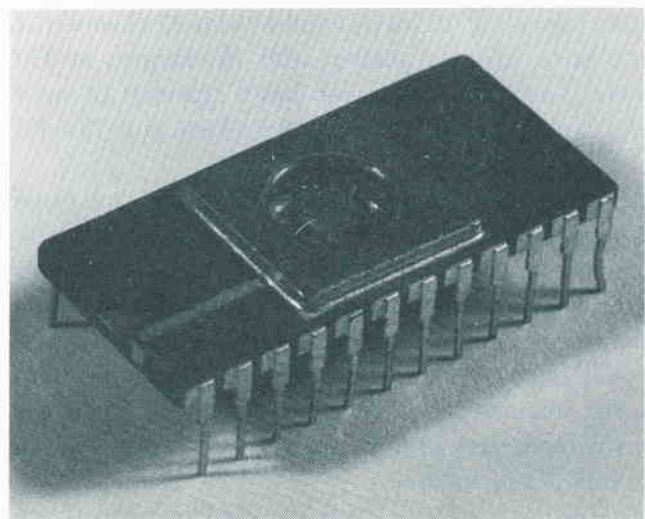
A chip or integrated circuit is constructed out of silicon with some other tiny particles of metal (impurities) embedded in specific positions in the silicon. By positioning the metals in certain ways, the manufacturing process forms tiny transistors. Applying a voltage to certain places on the chip allows the device to invert a voltage level (+5 volts, logic 1, to 0 volts, logic 0) and to enable all sorts of logic gates (AND, NAND, OR, NOR, etc.) to function. These chips can be made with silicon/metal junctions so tiny that today thousands of transis-

tors can be placed on one chip. A memory chip the size of a fingernail can hold over 470,000 transistors.

The problem for chip manufacturers is how to get voltages and signals into and out of such a tiny chip. Very thin wires are used as inputs and outputs to the chip. These wires are glued or bonded to tiny pads on the chip. The other end of each wire is bonded to a larger pad on a supporting material (the big part of what we call the integrated circuit, as shown in Fig. 6-12). This supporting structure includes the pins we plug into the sockets on our printed-circuit boards.

These tiny silicon and metal chips are placed in environments that really put them under a lot of stress. First they heat up when you use your computer. Then they cool down when you turn off your machine. Then they heat up again. This hot-cold-hot effect is called “thermal stress.” It affects those tiny strands of wire, or leads, going between the chip and the supporting structure that includes the large pins that are inserted into sockets. After a period of time, the thermal stress can cause the bonding of the wire lead to break away from the pad on the chip. This disconnect causes an input or output to become an “open” circuit, and chip replacement is required.

Another failure in these chips is caused by a phenomenon called “metal migration.” The chip can be compared to an ocean of atoms. Some tiny particles of metal float about in this sea, migrating in directions perpendicular to electrical current flowing through the chip. Problems occur when these metal particles begin to collect in parts of the chip. If they concentrate in the



**Fig. 6-12.** The tiny leads from the chip to the pins of the chip package are clearly seen in this photo.

middle of one of those microelectronic transistors, they cause the transistor to operate differently or not at all. If the resistance of these collected metals gets high enough, it causes the device to operate intermittently or to simply refuse to work. Since the failing transistor is part of a logic gate, the gate malfunctions and the output may become "stuck at 1" or "stuck at 0," no matter what the input signal is. Theoretically, a wear-out failure won't occur until after several hundred years of use. However, we shorten the life span of our chips by placing them in high-temperature, high-voltage, or power-cycling environments. These cause the devices to fail sooner.

Other problems occur outside the chip, between the chip leads and the support structure pin leads, the inputs and outputs of the device. These types of failures include inputs or outputs shorted to ground, pins shorted to the +5-volt supply, pins shorted together, open pins, and connectors with intermittent defects. The most common trouble (assuming power is available) are opens or shorts to ground. Under normal use, chips finally fail with an input or output shorted to ground.

## Capacitors

An understanding of the way a standard capacitor is constructed will aid in your understanding of how these devices fail.

In Chapter 3 you discovered that there are several types of capacitors on the PC system board and adapter cards. The capacitor is constructed of two separated plates. A voltage is placed across the plates, and for an instant current flows across the gap. But electrons immediately build up on one plate and cause the current flow to stop, leaving the capacitor charged to some voltage potential. In addition to storing a charge, capacitors are used to filter unwanted signal spikes (sharp, quick peaks of voltage) to ground.

The electrolytic capacitor is constructed as shown in Fig. 6-13. Two aluminum foils or plates are separated by a layer of porous paper soaked with electrolyte solution, a conductive liquid. On one plate (the positive plate) a thin layer of aluminum oxide is deposited. This layer is called the *dielectric*. A capacitor has an *anode* (the positive plate), and a *cathode* (the electrolyte). Electrons build up on one plate, causing it to become so negative that it prevents further current flow (remember that electrons have a negative charge).

Another type of capacitor is the *film capacitor*. It is constructed of alternating layers of aluminum foil and a

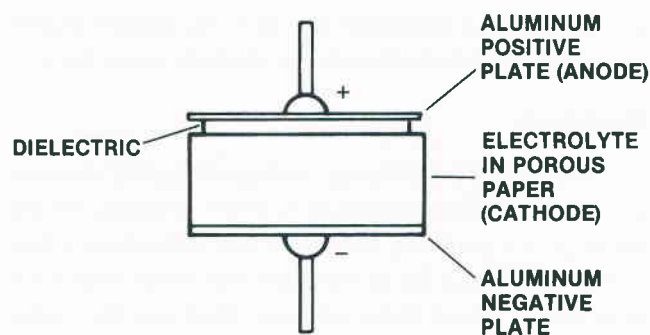


Fig. 6-13. The electrolytic capacitor.

plastic (usually polystyrene) insulation. The pieces of metal foil act as the plates, and the plastic insulation acts as the dielectric between the plates. A film capacitor is shown in Fig. 6-14. Film capacitors are coated with epoxy and have tinned copper leads.

Capacitors fail open or shorted depending on the operating conditions and on their age. Electrolytic capacitors are especially susceptible to the aging process. One effect of aging is drying out of the electrolyte insulator. As the insulator dries out, the capacitance value increases and circuit performance decreases. Finally, the capacitance value drops dramatically as the plates fold toward each other, and shorting of the plates can occur.

Another kind of failure occurs when some of the dielectric oxide dissolves into the moist electrolyte, causing the thickness of the dielectric to shrink. This deforming usually occurs when the electrolytic capacitor sits for a long time without voltage applied. In this case, the capacitance value increases but a large leakage of electrons occurs across the plates, making the capacitor useless.

The leads of the capacitor can physically detach from its plate, causing an open in the circuit. Also, the plates can short together when a large area of one plate is stripped of its dielectric oxide layer by the application of too much voltage.

Despite the potential for several kinds of failure, capacitors in our PC digital logic circuitry will seldom fail. A momentary power surge through the power sup-

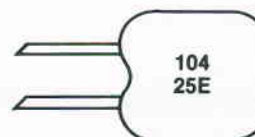


Fig. 6-14. The film capacitor.

ply can “fry” a capacitor on your PC system board. Excessive temperatures can also damage capacitors.

## Resistors

These current-limiting, voltage-dropping devices are quite reliable and should function properly for the life of your computer. However, the same factors that shorten the useful life of the chips also act to reduce the operational life of these resistors. High temperatures, high voltage, and power cycling all affect the materials of which the resistors are made. These stresses cause breaks in the carbon, resistive paste, or resistive layers, producing an open conduction path in the circuit. Excessively high voltages can produce electrical current so large that it actually chars resistors to burnt ash. This is rare, especially in a digital circuit, in which the highest voltage seen is 12 volts (usually 5 volts) and the currents are very tiny indeed (milliamps).

Resistor failures are almost always associated with catastrophic failure of some other circuit component. Resistor failures, when they occur, are usually located in printer electronics rather than in the system unit.

## Diodes and Transistors

The diodes and transistors on your computer’s system board and adapter cards are made of solid material and act much alike. In fact, the transistor can be considered to be made up, in part, of two diodes.

Diodes are one-way valves for electric current, allowing current flow in only one direction. Diodes are usually made of either silicon or germanium. They are used in power supplies as rectifiers and in some circuits to maintain a constant voltage level. Other diodes are made of gallium arsenide and react by giving off light when biased in a certain way. These are called light-emitting diodes, or LEDs.

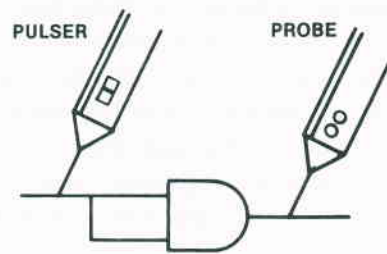
Transistors are used in various places in your computer circuitry as amplifiers or electronic switches.

Diodes and transistors fail in the same ways and for the same reasons as chips, but chips fail far more often than diodes or transistors. One reason is that there are many more tiny transistors on a chip the same size as a single (discrete) diode or transistor. This produces more heat and hence more thermal wear in the chip.

## USING TOOLS TO FIND FAILED COMPONENTS

Most chips on the IBM PC motherboard are TTL (transistor-transistor-logic) chips. If you know the logic

gates in a chip to be tested (NAND, NOR, OR, AND, etc.) you can test for opens or shorts by applying a known logic level to the inputs while monitoring the output. For example, if you were to place a slowly pulsing +5-volt to 0-volt signal on the input to the AND gate in Fig. 6-15, with both inputs shorted, you should see the output voltage level change (pulse) along with the input. Whenever the input is a logic 1, the output becomes a logic 1 (between +5 volts and +2.4 volts). The tool you use on the input is a logic pulser. The monitor tool on the output is a logic probe. The pulser places a cyclical logic level on the input to the device and the probe measures the presence or absence of a logic signal on the output of the chip.



**Fig. 6-15.** Pulsing the input should cause a change in the output as indicated by the logic probe.

If the input to the AND gate becomes shorted to ground, the pulser cannot cause the gate to react to its signal and the output remains at a logic 0, or LOW (about 0 volts). Even if just one of the inputs shorts to ground, the output cannot change and remains at a logic 0.

A short to the gate supply voltage (+5 volts) will have the effect of qualifying or enabling one input to the gate all the time. This means that each time the other input receives a logic 1, the input set is correct and causes the output to change to a logic 1 even though only one input signal was actually correct. This produces incorrect circuit operation and strange results. This is the kind of problem that shows up in memory circuits: only one of the inputs to a particular gate is shorted or opened; whenever this gate is used, the resulting output may or may not be correct—a difficult problem to trace down.

Shorting an input pin to +5 volts can have potentially disastrous results. When the previous gate tries to deliver a logic 0, or LOW, a huge current is produced which usually causes catastrophic failure of the driving chip. The same result occurs when the input pin is shorted to ground and the previous gate tries to deliver

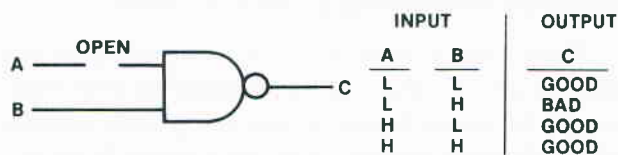
a logic 1, or HIGH. The +5-volt logic HIGH is shorted directly to ground, producing an unusually high current with equally disastrous results.

Open connections prevent logic levels from being transferred and prevent the affected gate from being able to respond. If one input of a two-input NAND gate is open at the input as shown in Fig. 6-16, all but one of the four possible input combinations will be correct. This means that with this type of failure, the system could operate correctly most of the time with only some of the inputs good. The failure would be intermittent.

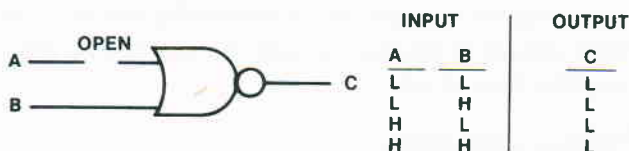
As shown in Fig. 6-17, if the device being tested is a NOR logic gate, the output would be a logic 1 only when both inputs are at logic 0. Should one of the inputs become open, it would float to logic 1 and cause none of the input conditions to produce a logic 1 output. Thus, the output would be LOW all the time—just as though the output were shorted to ground.

If the chip has an open pin at its output, it cannot deliver any logic 1 or 0 to the next gate. You can measure a voltage at the input to the next gate since it is providing the potential, a logic 1, or HIGH level (something around +4 volts). The key here is that any time an input to a TTL gate opens (a condition we call *floating*), the gate will act as though a logic 1 were constantly applied to that input. The voltage on this floating input will drift between the high supply voltage of +5 volts and a level (about 1.5 volts) somewhere between a valid HIGH and a valid LOW. (A valid HIGH is usually above +2.4 volts; a valid LOW is below +0.4 volts.)

A voltmeter reading of about +1.7 volts at the output pin of a gate on a chip is a clue that the output is



**Fig. 6-16.** An open at the input to a NAND gate is only a problem in one of four logic-state cases.

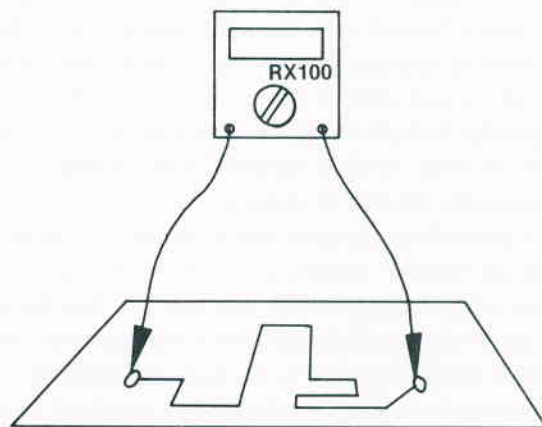


**Fig. 6-17.** An open at the input to a NOR gate will prevent the output from ever changing state or going HIGH.

floating open and the voltage is actually being provided by the next chip or the following gate.

All these kinds of failures can be located using a logic pulser and a logic probe with backup from a VTVM for voltage measurement.

Since the PC system board is flexible at certain points, replacing chips or depressing the board without supporting it from beneath could cause a break to occur, opening a trace on the circuit board. A hairline crack such as this is often difficult to find, but looking at the board with a magnifying glass and a strong light (or a magnifying lamp) can sometimes reveal a suspected failure. A resistance test can be conducted with a VOM or VTVM by placing a probe at either side of the suspected bad trace, as shown in Fig. 6-18, and observing whether a 0-ohm reading is measured. Another way to ascertain whether a trace is open is to compare the logic states at both ends of the trace.



**Fig. 6-18.** A trace can be tested for an open using an ohmmeter to test the electrical resistance from one end to the other.

An important fact to keep in mind when testing for individual shorted or open gates in the IBM PC system board circuitry is that more than one gate may use the same input or output lines to or from another gate. This is called *fan-in* or *fan-out*. When studying the gate circuitry, remember, the failure could be located at the other end of the board. One long trace from the end of the board to the chip you are looking at may be shorted or open at the distant end. Use of the schematics in the IBM PC technical reference manual will be of value here.

## OTHER TROUBLESHOOTING TECHNIQUES

There are some interesting tricks you can use to aid in finding chip failures.

### Use Your Senses

Look, smell, and feel. Sometimes failed components become discolored or develop bubbles or charred spots. Blown devices can produce some distinctive smells—the smell of a ruptured electrolytic capacitor, for example. Finally, shorted chips can get really hot. By using a “calibrated finger,” you can pick out the hot spots on your board.

### Heat It, Cool It

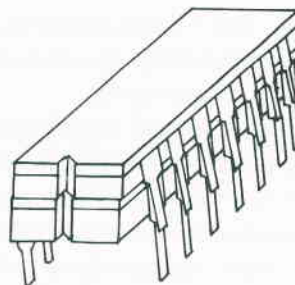
Heating and then cooling is a fast technique for locating the cause of intermittent failures. Frequently, as an aging device warms up under normal operation, it becomes marginal and then intermittently quits working. If you heat the energized area where a suspected bad chip is located until the intermittent failures begin, and then methodically cool each device with a short blast of canned coolant spray, you can quickly cause a marginally defective chip to function again. By alternately heating, cooling, heating, and cooling, you can pinpoint the trouble in short order.

You can heat the area with a hair dryer or a focused warm-air blower designed for electronic testing. Be careful using this technique, because the thermal stress you place on the chips being tested can shorten the life of good components. A 1- or 2-second spray of freeze coolant is all you should ever need to get a heat-sensitive component working again.

Most coolant sprays come with a focus applicator tube. Use this to pinpoint the spray. And avoid spraying electrolytic capacitors, because the spray soaks into the cap, destroying the electrolyte in some aluminum capacitors. Also be careful not to spray your own skin. You could get a severe frost burn.

### Piggybacking

Fig. 6-19 shows another way you can chase down intermittents caused by a break in a chip bond (wire) inside the chip housing that allows good contact only when the chip is cool. Place a good chip over the top of a suspected chip and energize the circuitry. You may need to squeeze the pins of the good chip in slightly so they make good contact with the pins of the suspected device.



**Fig. 6-19.** Some IC failures can be found by piggybacking a good device on a suspect device.

If the intermittent failure is caused by an open connection, the new chip will react to input data and cause its output to work properly. Use your stock of spare parts as your piggyback source.

### The Easter Egg Approach

Quite often we can quickly locate a fault to a couple of chips but need further testing to determine which chip is the culprit. When time is of essence, take an “Easter egg” approach. Just as a youngster used to pick up and examine Easter eggs one at a time to see whether his or her name was marked on it, you can try replacing the chips one at a time to determine whether the chip replaced was causing the problem. You have a fifty-fifty chance of selecting the right chip the first time. If it doesn’t work, replace the other chip.

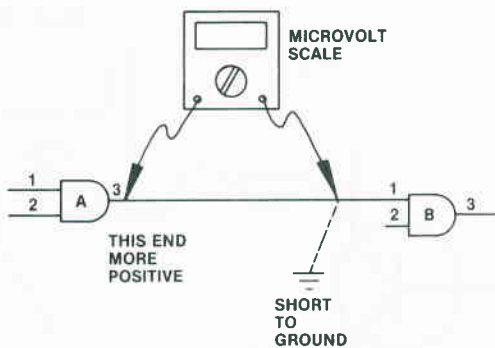
If the chips involved are inexpensive “jelly beans” (7400 series TTL), why not replace them both? For 30 cents more, go ahead and splurge. If the problem’s gone, but you’re still curious, you can always go back later and test each chip individually.

### Microvolt Measuring a Piece of Wire

If you have a meter with microvolt sensitivity and have isolated a “stuck LOW” problem to two chips, you can try the technique shown in Fig. 6-20. Measure the voltage drop between input pin 1 of gate B and output pin 3 of gate A. This means measuring the opposite ends of the same trace or piece of wire! You’re interested in determining which end of that trace is the more negative. The end nearest a bad chip will be more negative because the defective chip will short the trace voltage to ground, causing this point to be more negative than at pin 3.

### Testing Capacitors

How do you check out a capacitor that you believe has failed? If the device has shorted, resulting in severe



**Fig. 6-20.** A short circuit that is sinking current can be found using a meter with microvolt sensitivity.

leakage of current, you can spot this easily by placing an ohmmeter across the capacitor and reading the resistance. At first you'll notice a low reading, because the capacitor acts as a short until it charges; but then, if the capacitor is working properly, it will charge and the resistance will rise to a nominally high value. If the device is shorted, the initial low resistance reading continues and the capacitor won't charge.

Should the component be open, you'll not see the instantaneous short at  $T_0$ , the moment charge starts to build. An open circuit has infinite resistance. An in-circuit capacitance tester is helpful here.

Total failure as a short or open is pretty easy to find. But how about the device whose leakage depends on temperature or whose dielectric has weakened, changing the capacitance value? To test this capacitor requires a different level of analysis.

### Capacitance Measuring

If you have an ohmmeter whose face has the number 10 in the middle of the scale, you can easily use it to approximate the capacitance of a device. Using the time-constant formula,  $T=RC$ , where  $T$  equals the time in seconds for a capacitor to charge to 63.2 percent of supply voltage,  $R$  equals resistance in ohms, and  $C$  equals capacitance in farads. Using a 22- $\mu\text{F}$  capacitor and a 1 megohm (1,000,000 ohm) resistor, the charge time for one time constant is  $.000022 \times 1,000,000 = 22$  seconds.

Transposing the formula to read

$$C = T/R,$$

we can determine the value of capacitance by knowing the resistance and counting the seconds required for the charge to cause the ohmmeter needle to reach 63.2 percent of full scale (infinite resistance). This point is at about 17 on the meter's scale.

To do this, disconnect one end of a capacitor from the circuit, turn on your meter, and let it warm up for a minute. Zero adjust the ohms scale reading. Then estimate the ohms scale multiplier needed to let the capacitor charge in some acceptable time period. For microfarad capacitors use the "× 100K" scale because this will let the capacitor charge in less than a minute. The 17 on the scale represents 1.7 megohms on the × 100K scale.

Short a low-ohm-value resistor across the two capacitor leads for several seconds to thoroughly drain off any charge. Then connect the meter's ground lead to the negative side of the capacitor (either side if the capacitor is not electrolytic), and touch the positive meter probe to the other side of the capacitor. Using a stopwatch to count seconds and tenths of a second, watch the face of the ohmmeter as the capacitor charges, moving the resistance needle up. When the needle gets to 17 on the scale, stop the clock and read the time. This will give you the capacitance value in microfarads.

This technique will give you a close enough approximation of the capacitance value to determine whether the device is good or should be replaced.

### Replacing Capacitors

Always try to use the same type and value capacitor as the one being replaced. Keep the leads as short as possible and solder the capacitor into the solder connector holes with the proper iron. The soldering process should not take longer than 1.5 seconds per lead; otherwise, heat damage to the component may result.

A good technique to use is to tin the capacitor leads just before poking them through the circuit-board holes. This speeds the solder bond process.

### Testing Diodes

If you have a digital multimeter (DMM) with a diode test capability, you can quickly determine whether a suspected diode is bad or good. Placing the meter on the ohmmeter setting and positioning the probes across the diode causes the meter to apply a small amount of current through the diode if the diode is forward biased. The voltage drop across a diode is normally 0.2–0.3 volts for germanium diodes and 0.6–0.7 volts for silicon diodes. Reversing the leads should result in no current flow, so a higher resistance reading should be observed. A low resistance reading when the diode is biased in either direction indicates

that the device is leaking or shorted. A high resistance reading in both directions indicates the diode bond has opened. In either case, replace the diode immediately.

Diodes can also be tested in circuit, using the ohmmeter to check the resistance across a diode in both directions. With one polarity of the meter probes, you should get a reading different from that obtained when the probes are reversed — not just a few ohms different but several hundred ohms different. For example, in the forward-biased direction, you could read 50–80 ohms; in the reverse-biased direction, 300K ohms. This difference in readings is called DE for “diode effect” and is useful for evaluating transistors. When diode readings in both directions show low resistance, you can be sure the leaky short is present.

## Testing Transistors

It’s no fun to unsolder a transistor to test it for failure, and then, finding it good, solder it or a new device back into the circuit board. Fortunately, there is a way to determine the quality of silicon transistors without removing them from the circuit. In 90 percent of the tests, this procedure will accurately determine whether a device is bad.

A transistor acts like a configuration of diodes (Fig. 6-21). PNP and NPN transistors have opposite-facing diodes. The transistor functions by biasing certain pins and applying a signal to one of the leads (usually base) while taking an output off the collector or emitter.

The following tests apply to both PNP and NPN transistors. If an ohmmeter is placed between the collector (C) and the emitter (E) as shown in Fig. 6-22, it effectively bridges a two-diode combination in which the diodes are opposing. You should get a high resistance reading with the leads applied both ways. (It’s possible to wire the transistor in a circuit that makes the transistor collector-emitter junction act like a single diode. In this case you could get a DE. Both results are O.K.)

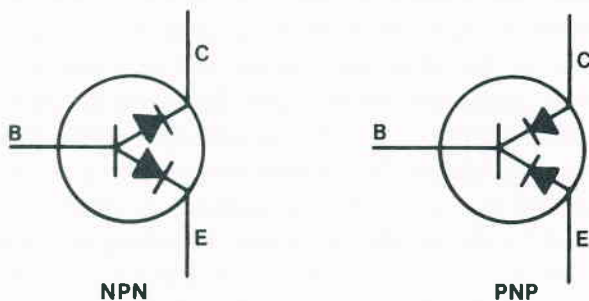


Fig. 6-21. A transistor acts like a pair of diodes.

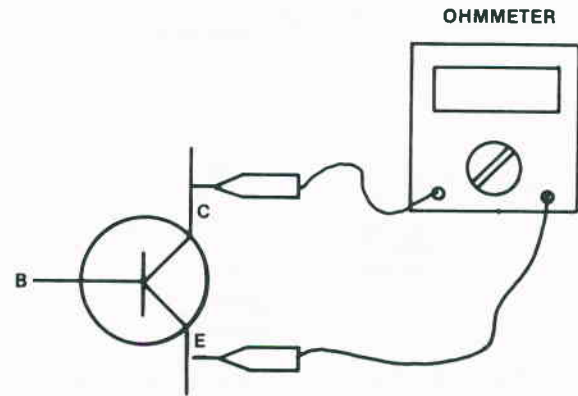


Fig. 6-22. A transistor can be tested using an ohmmeter placed across the collector-to-emitter junction.

Typical C-E resistance readings for germanium transistors are as follows:

Forward biased = 80 ohms

Reverse biased = 8000 ohms (8K)

For silicon transistors you might read

Forward biased = 22 megohms

Reverse biased = 190 megohms

The high/low ratio is evident and is about the same for both types.

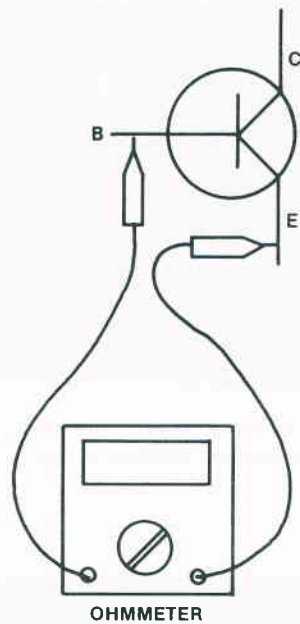
Place the probes across the collector-to-base junction. Reverse the probes. You should observe a low reading in one case and a high reading with the test probe leads reversed (the diode effect).

Try the same technique on the base-to-emitter (B-E) junction leads (Fig. 6-23). Look for the DE. If the DE is not present in all the above steps, you can be certain the transistor is bad and needs replacing.

Another way to evaluate a transistor is to measure the bias voltage from base to emitter on an energized circuit. Confirm the correct supply voltage first; power supply problems have been known to trick troubleshooters into thinking a certain component has failed.

The B-E forward bias for silicon transistors should be between 0.6 and 0.7 volts DC. If the reading is below 0.5 volts, replace the diode — the diode junction is leaking too much current. If the reading is almost a volt, the junction is probably open, and again the device should be replaced:

B-E Voltage (forward biased)	Action
0.5	Replace
0.6–0.7	Good, keep
0.9	Replace



**Fig. 6-23.** Check the base-to-emitter junction for diode effect (DE).

Although in some isolated cases some other failure could cause the low reading, the most common cause of low bias voltage is failure in the transistor itself.

If the previous tests are inconclusive, there is something else you can try. Measure the voltage across the collector-to-emitter (C-E) junction. If the reading is the same as the source supply (+5 volts for Q1 on the color/graphics adapter) and you notice on the schematic that there's plenty of resistance in the collector-base circuit, the junction is probably open. Replace the device.

If your reading is close to 0 volts, take a small length of wire and short the base to the emitter, removing all the transistor bias. The C-E meter reading should instantly rise. If it doesn't, the transistor is shorting internally and should be replaced. If C-E voltage does rise, it suggests a failure in the bias circuitry, perhaps a leaky coupling capacitor.

## SOLDERING AND UNSOLDERING

### Removing Solder

One way to remove residual solder is to use a "solder sucker"—a hand held vacuum pump with a spring-driven plunger to pull the hot, melted solder off a connector (Fig. 6-24). The process involves heating the old solder until it melts, placing the spring-propelled vacuum pump in the hot solder, and then

quickly removing the soldering iron while releasing the vacuum pump's spring, sucking the solder up into a storage chamber in the pump. This technique works fine until you try to use it around CMOS chips. Some vacuum pumps produce static electricity, and by now you know what that can do to an MOS or CMOS chip.

A safer way to remove solder is to touch the solder with the end of a strip of braided copper. Then heat the braid just a short distance from the solder (Fig. 6-25). The copper braid heats quickly, transferring the heat to the solder, which melts and is drawn into the braid by capillary action. Then, cut off the solder-soaked part of the braid and throw it away.

If any solder remains in the circuit-board hole, heat the solder and push a toothpick into the hole as the solder cools. The toothpick will keep the hole open so you can easily insert another wire lead for resoldering.

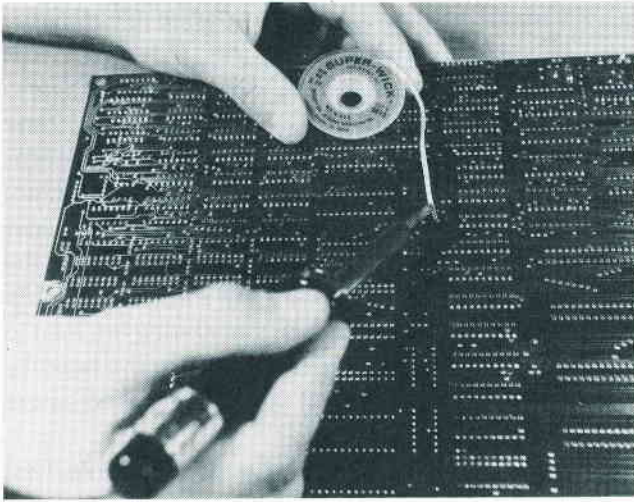
Another way to remove the residual solder blocking a hole is to drill out the hole with a tiny drill bit. Be sure to remove any debris, filings, or pieces of solder before energizing the circuit board. Use a magnifying glass to confirm that nothing unwanted remains on the board.

Be careful not to overheat the board during the solder-removal process. Excessive heat can cause part of the circuitry to come away from the board. It can also damage good components nearby.

If you remove the solder from a component and a lead is still stuck on some residual solder, pinch the



**Fig. 6-24.** The spring-driven plunger in the solder vacuum pump is used to pull hot solder off a connection.



**Fig. 6-25.** Use of a solder wick is another way to remove solder from a connection.

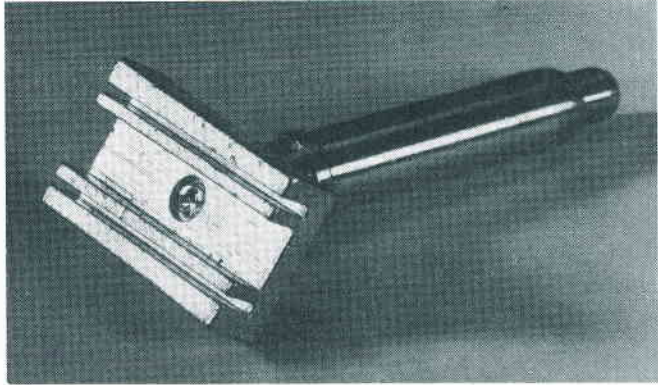
lead with a pair of needle-nose pliers as you gently wiggle it to break it loose from the solder bond.

The pins of some chips are bonded to the circuit board by a process called wave soldering. Wave soldering produces an exceptionally good bond without the added manufacturing expense of a socket. This process helps keep the fabrication costs down, but it makes it more difficult for you to replace the chip.

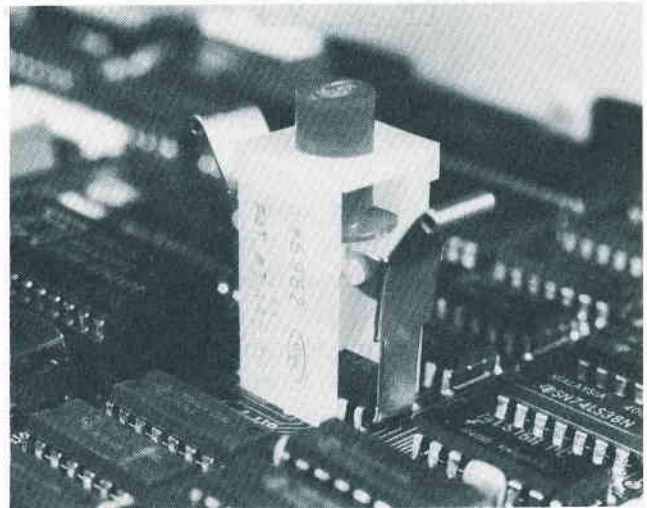
One effective way to remove wave-soldered chips is to cut the chip leads or pins on the sides of the component and remove the bad chip. Then remove the pieces of pin sticking through the board using a soldering iron and solder braid or a vacuum pump.

Some special tools are available to help you in removing soldered components. Fig. 6-26 shows a desoldering tip that fits over all the leads of a chip socket or dual in-line package (DIP) device. Fig. 6-27 is a photograph of a spring-loaded DIP extractor tool. By attaching this device to the chip and then applying the DIP tip shown in Fig. 6-26 to the soldered connections on the opposite side of the board, you can easily remove the chip. Press the load button downward and engage the clips, causing the extractor to place an upward spring pressure on the chip. When the solder on the reverse side melts enough, the chip will pop up and off the board.

When you replace a chip that was soldered to the printed-circuit board, always solder in a socket and then plug the replacement chip into this socket. This will make future replacements a lot easier. Be careful to maintain the correct pin 1 alignment.



**Fig. 6-26.** A desoldering tip for removing chips that are soldered to the circuit board.



**Fig. 6-27.** A spring-loaded dual-in-line extractor tool.

## Soldering Tips

No pun intended. Hand soldering is the most misunderstood and most often abused function in electronics repair. Not only do many people use poor soldering techniques, but they also use the wrong soldering irons.

Solder isn't simply an adhesive making two metals stick together. It actually melts and combines with the metals to form a consistent electrical as well as mechanical connection. Time and temperature are critical in this process. The typical hand-soldering job can be accomplished in 1.5 seconds or less if the soldering iron and tip are properly selected and then properly maintained.

The nominal solder melting temperature is 361° F. Metal combination between the solder and the metals

being joined occurs at temperatures between 500 and 600° F.

Most soldering jobs join the metals copper and tin, but both of these metals are easily oxidized. Poor or no solder connections are made if the surfaces to be connected are covered by contaminants such as oils, dirt, or even smog, so be sure to use solder with a good cleaning flux. The flux prepares the surfaces for best solder metalization. The flux melts first and flows over the metal surfaces, removing oxidation and other contaminants. Then the metal heats so that the solder melts and flows, producing a good, shallow bond.

The key to successful soldering is in the soldering iron tip. Most people selecting their first soldering iron buy a low-wattage iron, but this is a mistake. Instead, pick an iron whose tip operating temperature is suited for the circuit board you're to repair. If the tip temperature is too low, the tip sticks to the surface being soldered. If it's too high, it damages the board surface. The ideal working temperature for soldering on your computer's circuit board is between 600° and 700° F.

The soldering iron tip is used to transfer the heat generated in the iron out to the soldering surface. The iron should heat the tip quickly, and the tip should be as large as possible, yet slightly smaller than any soldering pad on the board.

Tips are made of copper. Copper conducts heat quickly, but it dissolves in contact with tin. Solder is made of tin and lead. To keep the tin from destroying the copper tip, manufacturers plate a thin layer of iron over the soldering tip. The hot iron (now you know where the term "iron" came from) still melts the solder, but now the tip lasts longer. The iron melts above 820° F, so if the heat produced by the iron stays below 700° F, the solder melts, but not the iron plating.

The disadvantages of the iron plating are that it doesn't conduct heat as well as copper, and it oxidizes rapidly. To counteract this, you can melt a thin coat of solder over the tip. This is called "tinning." This solder layer helps the soldering iron heat quickly and also prevents oxidation.

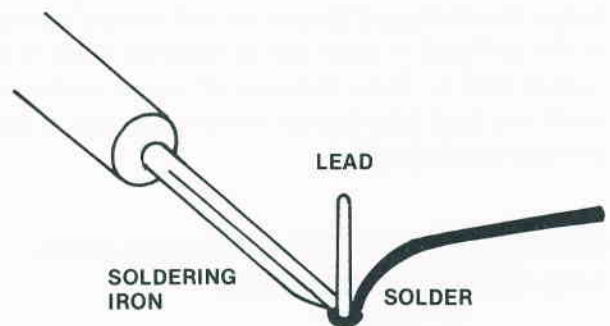
The tip of an old soldering iron is usually black or dirty brown with oxidation. And it doesn't conduct heat very well. These "burned-out" tips can be cleaned with fine emery cloth and then can be retinned and used.

Wiping the hot tip with a wet sponge just before returning the iron to its holder is a mistake. This removes the protective coating, exposing the tip surface to atmospheric oxidation. It's much better to add some fresh solder to the tip instead. Keep your iron well tinned.

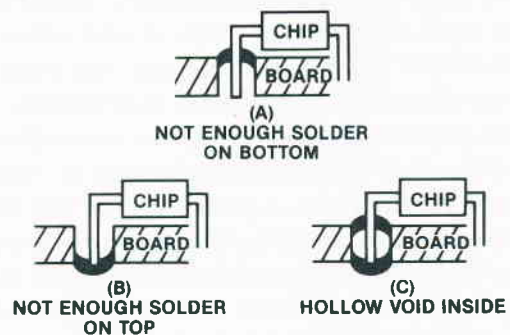
Fig. 6-28 shows the proper way to solder a socket or connector lead. Place the tip of the iron on one side of the lead and the solder on the other side.

As the solder pad heats, the tin-lead solder melts and flows evenly over the wire and the pad. Keep the solder shallow and relatively even. When you think your soldering job is complete, carefully inspect your work. Sometimes, if you aren't careful, you can put too much solder on the joint, so that there's not enough solder on the top or bottom of the connection. It's also possible to get internal voids or hollow places inside the solder joint. Large solder balls or mounds invite "cold solder joints" where only partial contact is made. Fig. 6-29 shows some examples of inadequate soldering. These kinds of solder joints can be a source for intermittent failure.

Good soldering takes patience, knowledge, and the right tools—a temperature-controlled soldering iron whose tip temperature is maintained in the 500–600° F range for optimal soldering effect.



**Fig. 6-28.** Place the soldering iron on the opposite side of the lead from the solder.



**Fig. 6-29.** Examples of inadequate soldering on a printed-circuit board.

## Before You Solder It In

A useful thing to do before you solder in a replacement part is to test the device in the circuit. Simply insert the chip or other device into the solder holes and wedge each lead in its hole with a toothpick. Then energize the circuit and test. After proper function is assured, remove the toothpicks and solder the component into the board.

## CIRCUIT BOARD REPAIR

Repairing damaged circuit boards is a lucrative business, and several companies have developed around this activity. For some board failures, you can repair your own circuitry and save money.

Before soldering in new components, check over the board for broken traces or pads lifting off the board. If a trace is open and is starting to lift away from the board surface, jumper across the broken spot from one component solder pad to another pad. Use solid #18 or #20 wire tinned at both ends before soldering.

If a pad or trace lifts free, replace it with an adhesive-backed pad or trace overlapping the damaged area. Scrape the coating off the pad or both ends of the trace so the new pad or trace can be soldered firmly to the existing pad or trace. Remove all excess solder and redrill any lead hole that has become covered or plugged with residual solder.

## RECOMMENDED TROUBLESHOOTING AND REPAIR EQUIPMENT

If you're planning to tackle failures that usually require service center support, you can minimize your investment costs and yet optimize your chance of success by carefully selecting your equipment and tools.

First, get a set of good screwdrivers—both Phillips and flat-head. Get a broad range of sizes—from the tiny “tweakers” to an 8-inch flat-head. You might also find a set of jeweler’s screwdrivers quite helpful.

Then get several sizes of long-nose or needle-nose pliers. Get several sizes of diagonal cutters, or “dykes,” for cutting wire and pins. A good soldering iron whose tip temperature is automatically controlled is a must if you intend to replace nonsocketed components. A simple 3½-digit DVM or DMM is useful for test measurements. Another handy tool is the logic probe.

If you can afford it, get a 15–25 MHz oscilloscope with dual trace and a time-base range of 200 nano-

seconds to a half second. Select a scope with a vertical sensitivity of 10 millivolts per division or better.

Table 6-1 shows an approximate price list for troubleshooting and repair equipment.

**Table 6-1. Approximate prices for troubleshooting and repair equipment**

Tool	Price (\$)
Screwdrivers—12	15
Pliers	15
4½-inch short-nose	
5¾-inch long-nose	
Diagonal cutters	10
4½-inch flush	
4½-inch midjet	
DMM (3½ digit)	80
Logic probe	85
Logic pulser	85
Current tracer	200
Logic clip	80
Oscilloscope	1200
Logic analyzer	1100

You can get by quite nicely for less than \$500 using the probe, pulser, tracer, and DMM as your primary equipment. Prices vary from one manufacturer to another.

## SPARE PARTS

Because of the cost involved you will probably want to maintain only a minimal stock of repair parts; yet you want to be able to fix your machine quickly when it breaks down.

The optimal backup bit would include one each of every type of chip on your PC's system board and adapter cards. This represents an investment of \$100 to \$200 in 150 or more chips. Currently, IBM PC custom chips—the ROMs—are available from authorized IBM service centers. The total number of chips in the PC is higher than the number of chips you need as spares because many of the same types of chips are used in different places on the system board. In addition, you only need one of the RAM chips as a spare. Your largest expense in chips will probably be for the ROMs (unless you are using a \$140 8087 coprocessor chip).

Several companies market spare-parts packages with schematics, diagnostic tests, and one each of the chips for the IBM PC.

In the Appendix you'll find a listing of each chip in your computer including its designation, name, and location.

## SUMMARY

There are four possible ways to optimize your computer system's operational life:

1. Buy a highly reliable computer with a good performance track record.
2. Buy a good on-site repair contract.
3. Buy a second identical computer to use as a backup during repair of the first.

4. Become a knowledgeable repair technician yourself.

Armed with the knowledge in this manual, you'll be able to spot downright poor troubleshooting—the "tech" using a bare cotton swab with low-grade alcohol, to "clean" a disk drive read head, the repair person wiping his or her soldering iron on a wet sponge just before putting it in its holder. These are mistakes of poorly trained (or poorly motivated) people working on someone else's machine. You'll also be able to recognize the sharp, highly trained technician who uses the right tools and the right procedures to troubleshoot and repair in minimum time. Then you'll smile to yourself, knowing that you were smart enough to buy this book and do your own repair the right way—the IBM-Easy way.



# Appendix

---

IBM PC Data Sheet . . . . .	181
IBM PC Chip Information Chart . . . . .	182
IBM PC System Unit Disassembly Instructions . . . . .	184
System Board Removal . . . . .	184
Power Supply Removal . . . . .	184
IBM PC System Unit Reassembly Instructions . . . . .	185
Reinstalling the System Board . . . . .	185
Power Supply Installation . . . . .	185
Reassembling the System Unit Case . . . . .	185
Keyboard Disassembly and Reassembly Instructions . . . . .	185
Keyboard Disassembly . . . . .	185
Keyboard Reassembly . . . . .	186
Disk Drive Disassembly and Reassembly Instructions . . . . .	186
Replacing Surface-Mounted Components on the System Board . . . . .	186
Useful Recordkeeping Forms . . . . .	186
Equipment History Record . . . . .	186
Record of Configuration Changes . . . . .	187
System Description . . . . .	187
Operational Log Sheet . . . . .	187
Routine Preventive Maintenance . . . . .	188
Summary of Cautions and Notes . . . . .	189
ASCII Code Chart . . . . .	190
Hexadecimal-to-Decimal Conversion Chart . . . . .	190

## IBM PC DATA SHEET

**Computer:** IBM Personal Computer

**Manufacturer:** IBM Corporation  
Armonk, New York

**Size:** 19.6 " × 16.1" × 5.5"

**Weight:** 20.9 lb without disk drive installed

**Power Required:** 63.5 watts (maximum)  
110/220 volts

**CPU:** 8088 microprocessor

**Data Word Size:** 8 bits

**CPU Clock Speed:** 4.77 MHz

**Memory Size:** 40K ROM  
16K–256K bytes on system board  
1 Mbyte directly addressable memory

**Mass Storage Capability:** Two disk drives internally  
Two disk drives externally  
160K bytes—single density  
320K bytes—double density

**Keyboard Size:** 83 keys  
256 character codes

**Display:** 25 lines of 40 characters, 16 colors  
25 lines of 80 characters, 16 colors

**Graphics Capability:** 100 rows of 160 picture elements  
(pixels), 16 colors  
200 rows of 320 pixels, 4 colors  
200 rows of 640 pixels, black and white  
32 special graphics characters

**Input/Output:** Five 62-pin expansion slots  
 Cassette connector  
 2¼-inch speaker  
 Auxiliary power connection  
 Detachable keyboard

**Standard Software:** Cassette BASIC

**Optional Software:** PC-DOS  
 Cassette BASIC  
 MS-DOS  
 Advanced BASIC

Label	Integrated Circuit	Description
U29	9264 ROM	8K × 8-bit static ROM
U30	9264 ROM	8K × 8-bit static ROM
U31	9264 ROM (MK36A70N-4)	8K × 8-bit static ROM
U32	9264 ROM	8K × 8-bit static ROM
U33	9264 ROM	8K × 8-bit static ROM
U34	8253	Programmable interval timer
U35	8237	DMA controller
U36	8255	Programmable peripheral interface

## IBM PC CHIP INFORMATION CHART (Refer to Fig. A-1)

Label	Integrated Circuit	Description
U1	MC1741	General-purpose operational amplifier
U2	8259	Programmable interrupt controller
U3	8088	Microprocessor
U4	8087	Numeric data processor
U5	74LS30	8-input NAND gate
U6	8288	Bus controller
U7	74LS373	Octal transparent latch
U8	74LS245	Tri-state octal transceiver
U9	74LS373	Octal transparent latch
U10	74LS373	Octal transparent latch
U11	8284	Clock generator
U12	74LS245	Tri-state octal transceiver
U13	74LS245	Tri-state octal transceiver
U14	74LS245	Tri-state octal transceiver
U15	74LS244	Tri-state octal buffer
U16	74LS244	Tri-state octal buffer
U17	74LS244	Tri-state octal buffer
U18	74LS373	Octal transparent latch
U19	74LS670	Tri-state 4 × 4 register file
U20	RN1	4.7K ohm DIP resistor network
U21	SW1	DIP switch
U22	RN2	2K-ohm DIP resistor network
U23	74LS244	Tri-state octal buffer
U24	74LS322	8-bit serial/parallel-in register with sign extend
U25	SW2	DIP switch
U26	74LS175	Quad-D flip-flop
U27	74LS02	Quad 2-input NOR gate
U28	empty	Spare ROM socket
U37	4164 RAM	64K × 1-bit dynamic RAM
U38	4164 RAM	64K × 1-bit dynamic RAM
U39	4164 RAM	64K × 1-bit dynamic RAM
U40	4164 RAM	64K × 1-bit dynamic RAM
U41	4164 RAM	64K × 1-bit dynamic RAM
U42	4164 RAM	64K × 1-bit dynamic RAM
U43	4164 RAM	64K × 1-bit dynamic RAM
U44	4164 RAM	64K × 1-bit dynamic RAM
U45	4164 RAM	64K × 1-bit dynamic RAM
U46	74LS138	1/8 decoder/demultiplexer
U47	74LS138	1/8 decoder/demultiplexer
U48	74LS138	1/8 decoder/demultiplexer
U49	74LS08	Quad 2-input AND gate
U50	74LS02	Quad 2-input NOR gate
U51	74LS04	Hex inverter
U52	74LS00	Quad 2-input NAND gate
U53	4164 RAM	64K × 1-bit dynamic RAM
U54	4164 RAM	64K × 1-bit dynamic RAM
U55	4164 RAM	64K × 1-bit dynamic RAM
U56	4164 RAM	64K × 1-bit dynamic RAM
U57	4164 RAM	64K × 1-bit dynamic RAM
U58	4164 RAM	64K × 1-bit dynamic RAM
U59	4164 RAM	64K × 1-bit dynamic RAM
U60	4164 RAM	64K × 1-bit dynamic RAM
U61	4164 RAM	64K × 1-bit dynamic RAM
U62	74LS158	Quad 2-input data selector/multiplexer
U63	74LS38	Quad 2-input NAND buffer
U64	74LS20	Dual 4-input NAND gate
U65	74LS138	1/8 decoder/demultiplexer
U66	74LS138	1/8 decoder/demultiplexer
U67	74LS74	Dual-D flip-flop
U68	RN3	4.7K ohm DIP resistor network

Label	Integrated Circuit	Description	Label	Integrated Circuit	Description
U69	4164 RAM	64K × 1-bit dynamic RAM	U87	4164 RAM	64K × 1-bit dynamic RAM
U70	4164 RAM	64K × 1-bit dynamic RAM	U88	4164 RAM	64K × 1-bit dynamic RAM
U71	4164 RAM	64K × 1-bit dynamic RAM	U89	4164 RAM	64K × 1-bit dynamic RAM
U72	4164 RAM	64K × 1-bit dynamic RAM	U90	4164 RAM	64K × 1-bit dynamic RAM
U73	4164 RAM	64K × 1-bit dynamic RAM	U91	4164 RAM	64K × 1-bit dynamic RAM
U74	4164 RAM	64K × 1-bit dynamic RAM	U92	4164 RAM	64K × 1-bit dynamic RAM
U75	4164 RAM	64K × 1-bit dynamic RAM	U93	4164 RAM	64K × 1-bit dynamic RAM
U76	4164 RAM	64K × 1-bit dynamic RAM	U94	74LS04	Hex inverter
U77	4164 RAM	64K × 1-bit dynamic RAM	U95	75477	Relay driver
U78	RN4	30-ohm DIP resistor network	U96	74LS74	Dual-D flip-flop
U79	74LS158	Quad 2-input data selector/multiplexer	U97	74S08	Quad 2-input AND gate
U80	74LS125	Quad tri-state buffer	U98	74LS175	Quad-D flip-flop
U81	74S00	Quad 2-input NAND gate	U99	74LS04	Hex inverter
U82	74S74	Dual-D flip-flop			
U83	74LS04	Hex inverter			
U84	74LS10	Triple 3-input NAND gate			
U85	4164 RAM	64K × 1-bit dynamic RAM			
U86	4164 RAM	64K × 1-bit dynamic RAM			

### Other Components

Location	Device	Description
D1	Type FC	Silicon diode
X1	Crystal	14.31818 MHz crystal oscillator

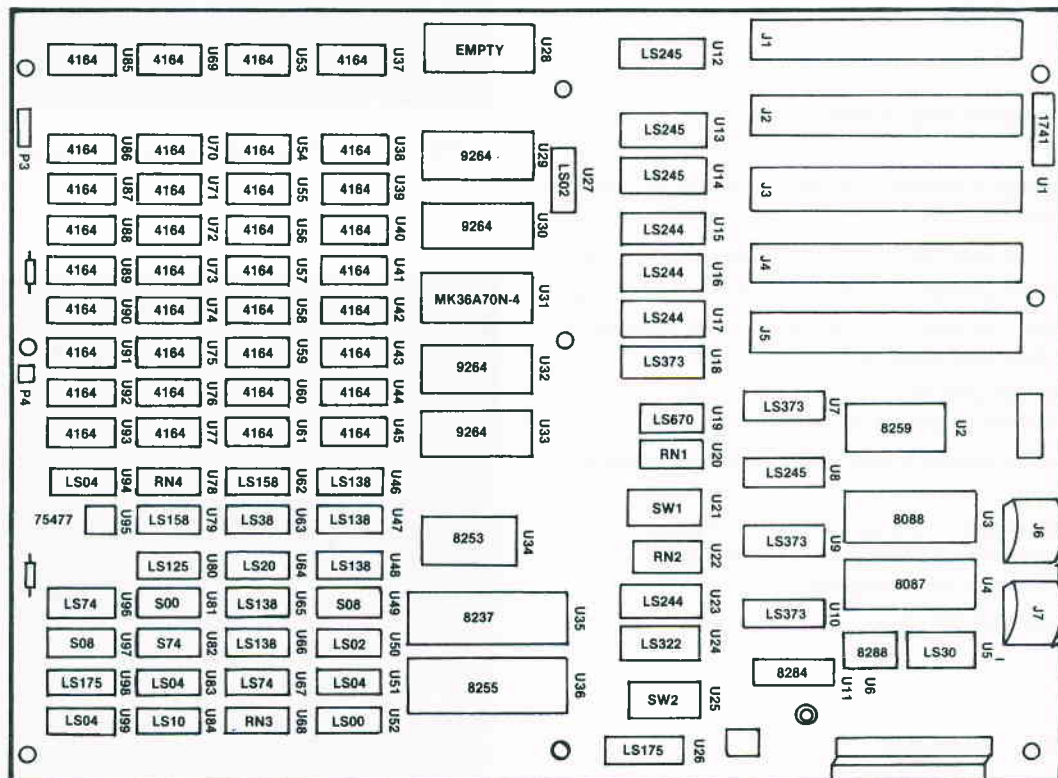


Fig. A-1. IBM Personal Computer motherboard chip location map.

## IBM PC SYSTEM UNIT DISASSEMBLY INSTRUCTIONS

These procedures apply to those repairs that require access to the internal subassemblies of the IBM PC system unit.

### System Board Removal

#### Tools and Equipment Required

- #2 flat-head screwdriver
- Uncluttered workspace
- Container to hold screws until reassembly

#### Procedure for System Board Access

1. Turn power off.
2. Unplug the power cord and any peripherals from the rear of the computer.
3. Position the system unit so the rear is facing you.
4. Using a flat-head screwdriver, remove the five screws from the rear plate. (Refer to Fig. A-2.)

**Note:** The older model IBM PC's have only three screws on the back plate.

5. Position the system unit so that the front is facing you.
6. Place your hands on either side of the cover and slide the cover off the main unit, pulling toward you as shown in Fig. A-3.

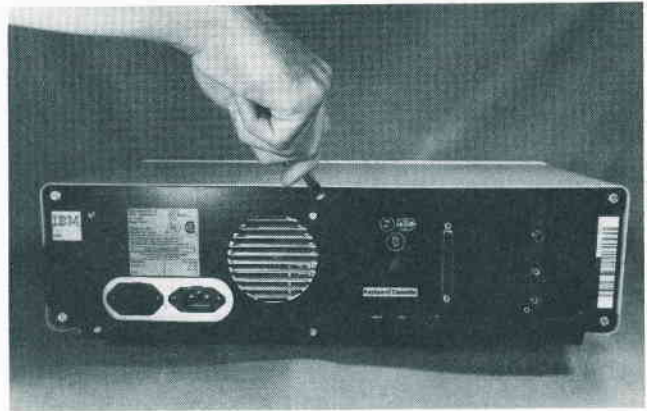
#### Procedure for Removing System Board

1. Follow steps 1 through 6 in the procedure for system board access.
2. Remove all peripheral cards from the system board.
3. Remove the power connector from the system board.
 

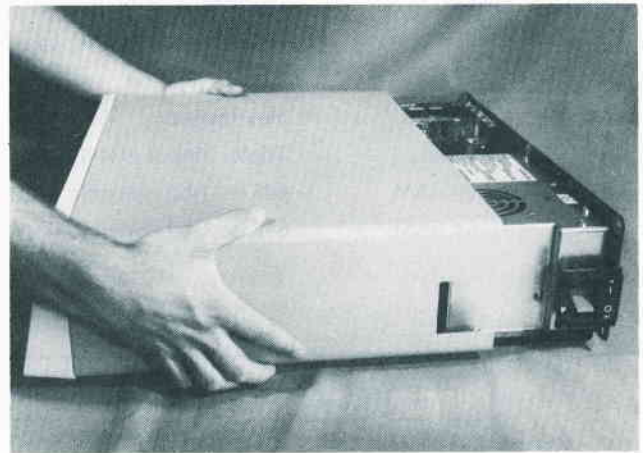
**Note:** The power connector is located in the back on the right side (looking from the front).
4. Remove the speaker cable from the connector on the lower middle section of the system board.
5. Remove the system board mounting screws as shown in Fig. A-4.
6. Slide the system unit board away from the power supply approximately 2 inches until the stand-offs can be lifted from their mounting slots.
7. Lift the system board from the system unit.

### Power Supply Removal

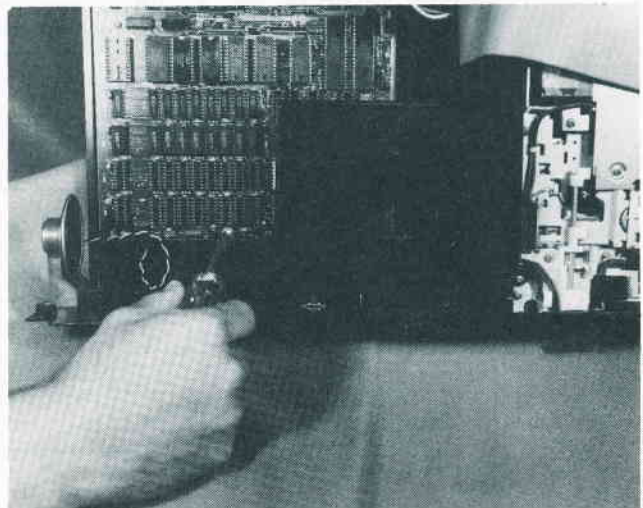
This section describes the steps required to remove the power supply from the chassis.



**Fig. A-2.** Remove these screws to disassemble the IBM PC.



**Fig. A-3.** Gently slide the system unit cover forward.



**Fig. A-4.** Remove the system-board mounting screws.

## Tools and Equipment Required

- #2 flat-head screwdriver
- Uncluttered workspace
- Container to hold screws until reassembly

## Procedure

1. Turn the power off.
2. Unplug the power cord and any peripherals from the rear of the computer.
3. Position the system unit so the rear is facing you.
4. Remove the system unit cover.
  - Note:** See "Procedure for system board access."
5. Remove the power connector from the system board.
  - Note:** This is located in the back on the right side looking from the front.
6. If you have drives hooked to your system, disconnect the power cables going to the drive analog cards.
7. Remove the four power supply screws on the back of the chassis.
8. Push the power supply forward about ½-inch.
9. To remove the supply, lift up and pull the power supply away from the motherboard.

## IBM PC SYSTEM UNIT REASSEMBLY INSTRUCTIONS

After the repair is complete, follow these steps to put your system back together.

### Reinstalling the System Board

#### Tools and Equipment Required

- #2 flat-head screwdriver
- Uncluttered workspace
- Container to hold screws until reassembly

#### Procedure for Replacing the System Board

1. Position all the stand-offs hooked to the system board above the mounting holes.
2. Gently push the system board toward the power supply until you can see that the mounting screw holes line up.
3. Reinstall the mounting screws in the system board.
4. Reconnect the signal wires to the speaker.
5. Install the adapter cards.
6. Reconnect the system board power supply connectors.

## Power Supply Installation

This section describes the steps needed to reinstall a power supply in the chassis.

### Tools and Equipment Required

- #2 flat-head screwdriver
- Uncluttered workspace
- Container to hold screws until reassembly

## Procedure

1. Hold the power supply unit approximately ½-inch from the rear of the chassis, and push the supply toward the motherboard and then back to align the screw holes in the chassis.
2. Replace the four mounting screws for the power supply.
3. Reconnect the disk drive power supply connectors.
4. Reconnect the motherboard power supply connectors.
5. Reconnect the power cord.
6. Power up and test.

## Reassembling the System Unit Case

1. Gently slide the system unit case forward over the system unit.
2. Reinstall the five flat-head screws on the back of the chassis.
  - Note:** The older model IBM PC has only three screws on the back plate.
3. Reconnect all peripherals and the power cord.

## KEYBOARD DISASSEMBLY AND REASSEMBLY INSTRUCTIONS

### Keyboard Disassembly

This section explains the proper procedures for disassembling the keyboard.

#### Tools and Equipment Required

- Small Phillips screwdriver
- Uncluttered workspace
- Container to hold screws until reassembly

#### Disassembly Procedure

1. Turn the system unit off.
2. Remove the keyboard from the connector in the back of the system unit.

3. Turn the keyboard upside down.
4. Remove the two Phillips screws from the bottom of the keyboard plate.
5. Lift the top of the plate up and out of the retaining slots in the chassis of the keyboard.
6. Disconnect the cable from the keyboard assembly.
7. Lift the rear of the keyboard out of the chassis.

### Keyboard Reassembly

This section explains the proper procedures for putting the keyboard back together after repairs have been made.

#### Tools and Equipment Required

- Small Phillips screwdriver
- Uncluttered workspace
- Container to hold screws until reassembly

#### Reassembly Procedure

1. Position the front of the keyboard assembly into the front of the keyboard chassis.
2. Lower the back of the keyboard down into the chassis.
3. Reconnect the cable to the keyboard assembly.
4. Put the tabs on the front of the base into the slots on the front of the keyboard chassis.
5. Slowly lower the back down—don't forget to include the adjustable legs on the bottom of the keyboard.
6. Install the two Phillips screws into the mounting holes on the bottom of the keyboard.
7. Reconnect the cable to the system unit assembly.
8. Power up and test.

## DISK DRIVE DISASSEMBLY AND REASSEMBLY INSTRUCTIONS

These procedures are covered in Chapter 5, "Routine Preventive Maintenance," page 135.

## REPLACING SURFACE-MOUNTED COMPONENTS ON THE SYSTEM BOARD

Desoldering and soldering on the IBM PC system board is not easy—the board construction is such that damage to the board traces and solder points can easily occur if you aren't extremely careful.

**Caution:** Proceed at your own risk.

1. Reread the section on soldering techniques found in Chapter 6.
2. Be sure you're using a temperature-controlled iron.
3. Disassemble the machine and remove the system board.
4. Place the board on its edge and locate the component to be replaced.
5. If possible, during chip removal, attach an extractor tool to the component to be replaced and use a DIP tip on your soldering iron to heat the pins and remove the chip. Or use a vacuum "solder sucker," or braided-copper wick and the temperature-controlled iron to heat the pins (start at the corners first, then desolder every other pin to avoid overheating one area of the board trace) until the component comes free.
6. Clean the solder holes using the techniques described in Chapter 6.
7. If a chip was removed, install an IC socket in its place on the system board. This lets you install a replacement chip into an already soldered connection, eliminating the need to solder directly to the chip pins themselves.
8. If a transistor is being replaced, install a transistor socket in the system board connection holes.
9. If a resistor, diode, or capacitor is being replaced, solder the leads directly in the opened holes in the board.
10. Reinstall the system board in the computer's housing.
11. Reassemble the computer.
12. Reconnect the power cord.
13. Power up and test.
14. Return the computer to service (or break back down again to replace another possibly faulty component).

**Reminder:** If your efforts didn't solve the problem, and you've replaced all the suspected components with good components, you have little recourse—pack it up, and take the system to a repair service center.

## USEFUL RECORDKEEPING FORMS

### Equipment History Record

#### EQUIPMENT HISTORY RECORD (Repair Action Log)

Name of Unit	Model	Serial Number	Card Number
--------------	-------	---------------	-------------

Manufacturer \_\_\_\_\_

Date Installed \_\_\_\_\_

Date	Nature of trouble	Cause of failure, description of work done	Name of part	Circuit symbol
_____	_____	_____	_____	_____
_____	_____	_____	_____	_____
_____	_____	_____	_____	_____

**(SAMPLE) EQUIPMENT HISTORY RECORD  
(Repair Action Log)**

Name of Unit	Model	Serial Number	Card Number
IBM PC	5150	9373985150	1
<b>Manufacturer</b>	IBM		
<b>Date Installed</b>	July 15, 1982		

Date	Nature of trouble	Cause of failure, description of work done	Name of part	Circuit symbol
1982				
09/22	Keys won't work	Bad keyboard cable	Cable	None
12/25	PM	Cleaned	—	—
1983				
03/01	PM	Cleaned	—	—
06/01	PM	Cleaned	—	—
09/01	PM	Cleaned	—	—
11/23	Read error	Disk speed off. Readjusted speed.	Drive A	Speed
1984				
01/03	PM	Cleaned, checked speed of disk drives.	—	—

**Record of Configuration Changes**

**RECORD OF CONFIGURATION CHANGES**

Name of Equipment	Serial Number	Model	Date Installed	Card Number
<b>Number</b>	<b>Kind of Change</b>	<b>Date of Change</b>		

**(SAMPLE) RECORD OF CONFIGURATION CHANGES**

Name of Equipment	Serial Number	Model	Date Installed	Card Number
IBM PC	9373985150	5150	07/15/82	1
<b>Number</b>	<b>Kind of Change</b>	<b>Date of Change</b>		
1	Filled on-board RAM to 256K	02/20/83		
2	Added CP/M interface adapter	04/05/84		

**System Description**

**SYSTEM DESCRIPTION**

**Hardware:**

System:	Model:	Serial Number:
<b>Memory Size:</b>	<b>Type</b>	<b>Serial Number</b>
<b>Disk Drives:</b>		
<b>Printer:</b>		
<b>Display:</b>		
<b>Modem:</b>		

**Software:**

System Utilities	Languages	Data Management Tools	Applications Software
<b>Communications software:</b>			

**(SAMPLE) SYSTEM DESCRIPTION**

**Hardware:**

System:	Model:	Serial Number:
System: IBM PC	Model: 5150	Serial Number: 9373985150
<b>Memory Size:</b> 256K	<b>Type</b>	<b>Serial Number</b>
<b>Disk Drives:</b>	Tandon	5306553
	Tandon	5306554
<b>Printer:</b>	Okidata Microline 92	840040
	Typrinter 221	1901
<b>Display:</b>	AMDEK Video 300	3285340
<b>Modem:</b>	Hayes SMARTMODEM 1200	162124063

**Software:**

System Utilities	Languages	Data Management Tools	Applications Software
PC-DOS	Adv BASIC	SuperCalc	WordStar
Quickcode	PASCAL/MT	dBase II	Stock Base
	CP/M 86		

**Communications software:**

- Modem 7
- Smartcom II

**Operational Log Sheet**

**OPERATIONAL LOG SHEET**

**Name of Equipment:** \_\_\_\_\_ **Serial Number:** \_\_\_\_\_

**Configuration:**

**DATE ON OFF DATE ON OFF DATE ON OFF**

## ROUTINE PREVENTIVE MAINTENANCE

Preventive maintenance, or PM, is one of the least used techniques for operational cost reduction, yet the savings that results can be substantial. If the equipment doesn't fail, you can't evaluate the bottom-line savings in conducting proper PM. But after your first mind-boggling repair bill, the fact will sink in: you might have prevented this failure by doing some easy, routine maintenance.

Someone once said "Time is money." Failure to take the time to do routine preventive maintenance can indeed cost money. Do your PMs!

Many manufacturers are not sure what an optimum PM schedule should be. Some companies prefer you don't do any PMs. (The effect is to cause more equipment repair business for their service people.) Among those who recommend PMs, there is great variation in recommended schedules for similar hardware (e.g., disk drives).

The listing that follows is a consensus of recommendations from manufacturers, dealers, and users and the author's own experience.

### Optimum PM Schedule

**Note:** Modify the schedule below if intermittents occur frequently.

#### Daily

Log operational time.

Estimate disk drive "run-light-ON" time; estimate printer "printing" time; estimate computer "power-ON" time.

Monitor humidity (a measure of static electricity).

#### Weekly

Clean computer system work area.

Pick up all loose trash; reshelve scattered books; restore magazines; toss out old printed paper; toss those "bad" disks you've been saving; wipe down hardware with anti-static, dust-absorbing cloth; wipe desk and bench space with antistatic cloth; vacuum shelves, desk, and floor.

Clean equipment housings and cases.

Wipe chassis with antistatic cloth; "wash" with lightly soaped damp cloth.

Clean display screens.

Use antistatic "dust-off" type spray or damp cloth of antistatic solution.

Clean drive read head (after 40 hours of "run-light-ON" use).

#### Monthly

Clean inside computer.

Disassemble according to the procedures in this Appendix; use soft brush and long narrow vacuum cleaner hose nozzle (it helps to spray the nozzle with antistatic solution first).

Clean inside printer.

Use same technique as for cleaning inside computer.

Check ventilation filters in equipment.

Replace if cleaning is not practical (filter becomes worn or badly soiled).

Check connector contacts.

Look for signs of corrosion, pitting, or discoloration; clean if necessary; the corrosion-removing wipes that also coat the surface with a lubricating coating to protect it from atmospheric corrosion are strongly recommended.

Some manufacturers recommend that you also demagnetize the drive read head (after 40 hours of "run-light-ON" use).

### Every Other Month

Reseat socketed chips on the motherboard.

Disassemble according to the procedures in this Appendix.

Disconnect and reconnect cable and connector plugs.

This removes corrosion buildup.

Apply antistatic treatment to computer work area.

See Chapter 6 for details.

Clean inside printer.

Use nonmagnetic, plastic vacuum hose nozzle and soft camel hair brush; spray or wipe nozzle with antistatic spray or solution first.

### Every Six Months

Replace vent filters.

Do this only if you have filters; none are standard in the IBM PC.

Check disk drive speed.

Speed test programs are advertised in computer publications; remember the fluorescent light, strobe mark test (see Chapter 6).

Check head alignment.

Do this only if you suspect a disk problem.

Clean connector contacts.

If you haven't done this during earlier inspection checks, conduct this PM now; do this PM more often if your computer system is used in a smoggy part of the country or near salt air.

Clean disk drive read head.

If you use your system daily, your drive heads may need cleaning about now, but this depends very much on the kind and quality of disks you use.

Conduct routine inspection of printer.

Do this every 6 months or 500,000 lines of print; check the tightness of the screws and connectors; conduct a printer self test as described in the printer owner's manual.

### Annually

Take routine maintenance infrared photo (optional).

## SUMMARY OF CAUTIONS AND NOTES

The following is a listing of the **Caution** and **Note** statements used in this troubleshooting and repair guide. They are repeated here so you can review them quickly. It's a good idea to review them periodically.

- Never insert or remove a peripheral connector without first turning off the power to the computer, grounding yourself, and then reaching around in back of the computer and pulling the power plug out.
- Any time you open the computer, ensure that the power is off and that you have grounded any stray static electricity you might have been carrying.
- For any procedures conducted with the IBM PC open and with the computer operating, be careful not to short out any connectors or pin leads. Use only a nonmetallic or wooden object inside an energized computer.
- Keep out of the display chassis.
- Stay out of the power supply.
- Use a power strip. Plug the IBM PC and all peripherals (except a hard disk drive) into a switch-controlled strip.
- Keep liquids away from the computer.
- Handle components with care.
- When cleaning, make *sure* that the power is off and that all plugs are pulled out of the power sockets. Use a damp cloth. Don't let any liquid run or get into your equipment.
- When rubbing to clean contacts, always rub *lengthwise* along the pin.
- When using a logic clip, turn the power to the circuit off, attach the clip, and then turn the power on. This helps prevent accidentally shorting out a chip.
- In the event of a lightning storm, unplug your entire system.
- Don't use power tools near your computer while it's operating.
- IBM PC-Easy steps to success:
  1. Don't panic.
  2. Observe the conditions.
  3. Use your senses.
  4. Retry.
  5. Document.
  6. Assume one problem.
  7. Diagnose to a section (fault identification).
  8. Consult the symptom index (error code interpretation and problem matching).
  9. Localize to a stage.
  10. Isolate to a failed part.
- 11. Repair.
- 12. Test and verify.
- Keep cables clear and away from power cords, especially coiled power cords.
- Be careful not to flex the system board or other boards too much.
- It's a good idea to log the repair action in a record book to develop a history of the maintenance conducted on the machine (see pages 186–187 for "Equipment History Records").
- Don't wait for lightning to strike before you protect your computer system investment from electrical surges.
- Always unplug your computer system when blackout occurs.
- Never touch contacts with your fingers.
- Keep your diskettes, and even your information cables, away from power sources.
- You can damage the disk drive electronics if you attach the cable incorrectly (see your disk drive owner's manual).
- Handle diskettes carefully. Don't leave the disks lying around. Keep the disks in protective jackets. Don't touch the disk surface with your fingers. Keep the disks out of the hot sun.
- Don't use both sides of your disks in a single-sided drive.
- To extend disk life
  - Buy name brand disks.
  - Never touch the disk surface.
  - Never slam the disk drive door closed on a disk.
  - Store disks in their protective jackets.
  - Never write on a label that's already on a disk.
  - Store disks in a cool, clean place.
  - Back up all data disks.
  - Store working disks and backup disks in different places.
  - Never allow smoking near your disks or your drive.
  - Never set disks near monitors or televisions.
  - Avoid placing disks near vacuum cleaners and large motors.
  - Don't bend or fold disks.
  - Don't put disks through airport X-ray machines.
- Clean the read/write heads after every 40 hours of disk operation.
- Provide adequate ventilation when cleaning read heads with solvent.
- Make sure the solvent evaporates before you operate the drive.
- If disk drive speed adjustment seems difficult (see Chapter 5), have a repair service shop do it.

## ASCII CODE CHART

The following table lists all the ASCII codes (in decimal) and their associated characters. These characters can be displayed using PRINT CHR\$(n), where *n* is the ASCII code. The column headed "Control Character" lists the standard interpretations of ASCII codes 0 to 31 (usually used for control functions or communications).

Each of these characters may be entered from the keyboard by pressing and holding the Alt key, then pressing the digits for the ASCII code on the numeric keypad. Note, however, that some of the codes have special meaning to the BASIC program editor—the program editor uses its own interpretation for the codes and may not display the special character listed here.

ASCII value	Character	Control character	ASCII value	Character	ASCII value	Character	ASCII value	Character
000	(null)	NUL	032	(space)	064	@	096	`
001	☺	SOH	033	!	065	A	097	a
002	●	STX	034	"	066	B	098	b
003	♥	ETX	035	#	067	C	099	c
004	♦	EOT	036	\$	068	D	100	d
005	♣	ENQ	037	%	069	E	101	e
006	♠	ACK	038	&	070	F	102	f
007	(beep)	BEL	039	'	071	G	103	g
008	■	BS	040	(	072	H	104	h
009	(tab)	HT	041	)	073	I	105	i
010	(line feed)	LF	042	*	074	J	106	j
011	(home)	VT	043	+	075	K	107	k
012	(form feed)	FF	044	,	076	L	108	l
013	(carriage return)	CR	045	-	077	M	109	m
014	♪	SO	046	.	078	N	110	n
015	☼	SI	047	/	079	O	111	o
016	▶	DLE	048	0	080	P	112	p
017	◀	DC1	049	1	081	Q	113	q
018	↕	DC2	050	2	082	R	114	r
019	!!	DC3	051	3	083	S	115	s
020	π	DC4	052	4	084	T	116	t
021	§	NAK	053	5	085	U	117	u
022	▬	SYN	054	6	086	V	118	v
023	↑	ETB	055	7	087	W	119	w
024	↑	CAN	056	8	088	X	120	x
025	↓	EM	057	9	089	Y	121	y
026	→	SUB	058	:	090	Z	122	z
027	←	ESC	059	;	091	[	123	{
028	(cursor right)	FS	060	<	092	\	124	
029	(cursor left)	GS	061	=	093	]	125	}
030	(cursor up)	RS	062	>	094	^	126	~
031	(cursor down)	US	063	?	095	_	127	␣

### HEXADECIMAL-TO-DECIMAL CONVERSION CHART

ASCII value	Character	ASCII value	Character	ASCII value	Character	Hex	Dec	Hex	Dec	Hex	Dec	Hex	Dec	Hex	Dec
128	Ç	177	☒	226	┘										
129	ü	178	☓	227	π	Hex	Dec	Hex	Dec	Hex	Dec	Hex	Dec	Hex	Dec
130	é	179	┘	228	Σ	\$00	00	\$34	52	\$68	104	\$9C	156	\$D0	208
131	â	180	┘┘	229	σ	\$01	01	\$35	53	\$69	105	\$9D	157	\$D1	209
132	ä	181	┘┘┘	230	μ	\$02	02	\$36	54	\$6A	106	\$9E	158	\$D2	210
133	à	182	┘┘┘┘	231	τ	\$03	03	\$37	55	\$6B	107	\$9F	159	\$D3	211
134	á	183	┘┘┘┘┘	232	ϕ	\$04	04	\$38	56	\$6C	108	\$A0	160	\$D4	212
135	ç	184	┘┘┘┘┘┘	233	ϕ	\$05	05	\$39	57	\$6D	109	\$A1	161	\$D5	213
136	ê	185	┘┘┘┘┘┘┘	234	Ω	\$06	06	\$3A	58	\$6E	110	\$A2	162	\$D6	214
137	ë	186	┘┘┘┘┘┘┘┘	235	δ	\$07	07	\$3B	59	\$6F	111	\$A3	163	\$D7	215
138	è	187	┘┘┘┘┘┘┘┘┘	236	δ	\$08	08	\$3C	60	\$70	112	\$A4	164	\$D8	216
139	ï	188	┘┘┘┘┘┘┘┘┘┘	237	∅	\$09	09	\$3D	61	\$71	113	\$A5	165	\$D9	217
140	î	189	┘┘┘┘┘┘┘┘┘┘┘	238	€	\$0A	10	\$3E	62	\$72	114	\$A6	166	\$DA	218
141	í	190	┘┘┘┘┘┘┘┘┘┘┘┘	239	∩	\$0B	11	\$3F	63	\$73	115	\$A7	167	\$DB	219
142	Ä	191	┘┘┘┘┘┘┘┘┘┘┘┘┘	240	≡	\$0C	12	\$40	64	\$74	116	\$A8	168	\$DC	220
143	Å	192	┘┘┘┘┘┘┘┘┘┘┘┘┘┘	241	±	\$0D	13	\$41	65	\$75	117	\$A9	169	\$DD	221
144	E	193	┘┘┘┘┘┘┘┘┘┘┘┘┘┘┘	242	≥	\$0E	14	\$42	66	\$76	118	\$AA	170	\$DE	222
145	æ	194	┘┘┘┘┘┘┘┘┘┘┘┘┘┘┘┘	243	≤	\$0F	15	\$43	67	\$77	119	\$AB	171	\$DF	223
146	Æ	195	┘┘┘┘┘┘┘┘┘┘┘┘┘┘┘┘┘	244	∫	\$10	16	\$44	68	\$78	120	\$AC	172	\$E0	224
147	ô	196	┘┘┘┘┘┘┘┘┘┘┘┘┘┘┘┘┘┘	245	∫	\$11	17	\$45	69	\$79	121	\$AD	173	\$E1	225
148	ö	197	┘┘┘┘┘┘┘┘┘┘┘┘┘┘┘┘┘┘┘	246	∫	\$12	18	\$46	70	\$7A	122	\$AE	174	\$E2	226
149	ò	198	┘┘┘┘┘┘┘┘┘┘┘┘┘┘┘┘┘┘┘┘	247	∫	\$13	19	\$47	71	\$7B	123	\$AF	175	\$E3	227
150	û	199	┘┘┘┘┘┘┘┘┘┘┘┘┘┘┘┘┘┘┘┘┘	248	∫	\$14	20	\$48	72	\$7C	124	\$B0	176	\$E4	228
151	ù	200	┘┘┘┘┘┘┘┘┘┘┘┘┘┘┘┘┘┘┘┘┘┘	249	•	\$15	21	\$49	73	\$7D	125	\$B1	177	\$E5	229
152	ÿ	201	┘┘┘┘┘┘┘┘┘┘┘┘┘┘┘┘┘┘┘┘┘┘┘	250	•	\$16	22	\$4A	74	\$7E	126	\$B2	178	\$E6	230
153	Ö	202	┘┘┘┘┘┘┘┘┘┘┘┘┘┘┘┘┘┘┘┘┘┘┘┘	251	√	\$17	23	\$4B	75	\$7F	127	\$B3	179	\$E7	231
154	Ü	203	┘┘┘┘┘┘┘┘┘┘┘┘┘┘┘┘┘┘┘┘┘┘┘┘┘	252	√	\$18	24	\$4C	76	\$80	128	\$B4	180	\$E8	232
155	€	204	┘┘┘┘┘┘┘┘┘┘┘┘┘┘┘┘┘┘┘┘┘┘┘┘┘┘	253	√	\$19	25	\$4D	77	\$81	129	\$B5	181	\$E9	233
156	£	205	┘┘┘┘┘┘┘┘┘┘┘┘┘┘┘┘┘┘┘┘┘┘┘┘┘┘┘	254	√	\$1A	26	\$4E	78	\$82	130	\$B6	182	\$EA	234
157	¥	206	┘┘┘┘┘┘┘┘┘┘┘┘┘┘┘┘┘┘┘┘┘┘┘┘┘┘┘┘	255	■	\$1B	27	\$4F	79	\$83	131	\$B7	183	\$EB	235
158	Pt	207	┘┘┘┘┘┘┘┘┘┘┘┘┘┘┘┘┘┘┘┘┘┘┘┘┘┘┘┘┘		(blank 'FF')	\$1C	28	\$50	80	\$84	132	\$B8	184	\$EC	236
159	f	208	┘┘┘┘┘┘┘┘┘┘┘┘┘┘┘┘┘┘┘┘┘┘┘┘┘┘┘┘┘┘			\$1D	29	\$51	81	\$85	133	\$B9	185	\$ED	237
160	á	209	┘┘┘┘┘┘┘┘┘┘┘┘┘┘┘┘┘┘┘┘┘┘┘┘┘┘┘┘┘┘┘			\$1E	30	\$52	82	\$86	134	\$BA	186	\$EE	238
161	í	210	┘┘┘┘┘┘┘┘┘┘┘┘┘┘┘┘┘┘┘┘┘┘┘┘┘┘┘┘┘┘┘┘			\$1F	31	\$53	83	\$87	135	\$BB	187	\$EF	239
162	ó	211	┘┘┘┘┘┘┘┘┘┘┘┘┘┘┘┘┘┘┘┘┘┘┘┘┘┘┘┘┘┘┘┘┘			\$20	32	\$54	84	\$88	136	\$BC	188	\$F0	240
163	ú	212	┘┘┘┘┘┘┘┘┘┘┘┘┘┘┘┘┘┘┘┘┘┘┘┘┘┘┘┘┘┘┘┘┘┘			\$21	33	\$55	85	\$89	137	\$BD	189	\$F1	241
164	ñ	213	┘┘┘┘┘┘┘┘┘┘┘┘┘┘┘┘┘┘┘┘┘┘┘┘┘┘┘┘┘┘┘┘┘┘┘			\$22	34	\$56	86	\$8A	138	\$BE	190	\$F2	242
165	Ñ	214	┘┘┘┘┘┘┘┘┘┘┘┘┘┘┘┘┘┘┘┘┘┘┘┘┘┘┘┘┘┘┘┘┘┘┘┘			\$23	35	\$57	87	\$8B	139	\$BF	191	\$F3	243
166	a	215	┘┘┘┘┘┘┘┘┘┘┘┘┘┘┘┘┘┘┘┘┘┘┘┘┘┘┘┘┘┘┘┘┘┘┘┘┘			\$24	36	\$58	88	\$8C	140	\$C0	192	\$F4	244
167	o	216	┘┘┘┘┘┘┘┘┘┘┘┘┘┘┘┘┘┘┘┘┘┘┘┘┘┘┘┘┘┘┘┘┘┘┘┘┘┘			\$25	37	\$59	89	\$8D	141	\$C1	193	\$F5	245
168	c	217	┘┘┘┘┘┘┘┘┘┘┘┘┘┘┘┘┘┘┘┘┘┘┘┘┘┘┘┘┘┘┘┘┘┘┘┘┘┘┘			\$26	38	\$5A	90	\$8E	142	\$C2	194	\$F6	246
169	[	218	┘┘			\$27	39	\$5B	91	\$8F	143	\$C3	195	\$F7	247
170	[	219	┘┘┘			\$28	40	\$5C	92	\$90	144	\$C4	196	\$F8	248
171	½	220	┘┘			\$29	41	\$5D	93	\$91	145	\$C5	197	\$F9	249
172	¼	221	┘┘┘			\$2A	42	\$5E	94	\$92	146	\$C6	198	\$FA	250
173	i	222	┘┘			\$2B	43	\$5F	95	\$93	147	\$C7	199	\$FB	251
174	«	223	┘┘┘			\$2C	44	\$60	96	\$94	148	\$C8	200	\$FC	252
175	»	224	┘┘			\$2D	45	\$61	97	\$95	149	\$C9	201	\$FD	253
176	☒	225	┘┘┘			\$2E	46	\$62	98	\$96	150	\$CA	202	\$FE	254
			┘┘			\$2F	47	\$63	99	\$97	151	\$CB	203	\$FF	255
			┘┘┘			\$30	48	\$64	100	\$98	152	\$CC	204		
			┘┘			\$31	49	\$65	101	\$99	153	\$CD	205		
			┘┘┘			\$32	50	\$66	102	\$9A	154	\$CE	206		
			┘┘			\$33	51	\$67	103	\$9B	155	\$CF	207		



# Glossary

---

## A

- Adapter** A printed-circuit card or board used to connect peripheral equipment such as disk drives and display monitors to the IBM PC.
- Address** A number that represents a unique location in IBM PC memory.
- Address bus** The collection of 16 wires that carry the memory address from the CPU to the memory or to an external storage device.
- Alphanumeric** A character set containing letters and digits.
- ALU** Arithmetic logic unit.
- American Standard Code for Information Interchange** A code representing the character symbols possible for specific hexadecimal codes.
- Analog** An electrical signal in which information is represented by the level of voltage (e.g., 0 volts, 1.5 volts, and 3.7 volts all carry information). This is the opposite of binary, a digital system that has only two levels—0 volts for logic 0 and +5 volts for logic 1.
- AND** A logic gate used in the IBM PC computer; the output is HIGH, or logic 1, if, and only if, all inputs are also logic HIGH.
- Arithmetic logic unit** The portion of the CPU that performs arithmetic and logical operations.
- ASCII** American Standard Code for Information Interchange.

## B

- BASIC** Beginner's All-purpose Symbolic Instruction Code; an easy-to-learn high-level language.
- Basic input/output system** The part of the operating system that controls the input and output functions other than those involving the disk drive.
- Baud** A unit of measurement for the speed of digital communications; 1 baud equals 1 bit per second.
- Binary** A condition in which only two states can exist. Binary numbers are 0 and 1. These can be related to OFF (0) and ON (1) or FALSE (0) and TRUE (1).
- BIOS** Basic input/output system.
- Bit** Bit is a contraction of binary digit. It is the smallest unit of information storage and is combined with other bits to form the address and data words in your IBM PC.
- Blackout** The complete loss of electrical power.
- Boot (bootstrap)** A technique for loading a routine into main memory by loading several instructions that then bring the entire routine into main memory. The program, in effect, pulls itself up to completion by its "bootstrap."
- Brownout** A deliberate reduction in the electrical line voltage; usually caused by excessive electrical demand or insufficient power generation capability.
- Buffer** A storage location in an electronic chip that is used to temporarily hold data during electronic communication between two devices that are operating at different speeds. It may also be used to temporarily hold data until a data path is clear.
- Bus** The main communication circuit in a computer. Each register and location in memory is connected to the bus. The bus needs to consist of as many wires as there are bits in the computer words. For instance, there are 16 wires in the address bus to carry 16 bits of information.

**Byte** The size of the data word in your computer. A byte is 8 bits wide and represents a numerical value between 0 and 255 (decimal).

## C

**Cathode ray tube** The display screen used in computer systems for viewing data and graphics.

**Central processing unit** The 8088 microprocessor, which is the heart of your computer. This portion of the computer is composed of the ALU and the control unit. It fetches, decodes, and executes instructions and controls the overall activity of the computer is controlled.

**Channel** A pathway for input or output of information. The expansion slots are called the PC's I/O channel.

**Chip** An integrated circuit created on a small silicon flake. It consists of a large number of gates and the paths connecting them, formed by very thin films of metal acting as wires. The term "chip" includes the silicon flake as well as the plastic support package.

**Clock** A circuit that sends a consistent, periodic signal that is used to step logic information through a computer circuit.

**Cold boot** Initializing the start-up conditions in your IBM PC computer. The cold boot process assumes no previous activity in the computer and sets all the registers in the machine to initial conditions.

**Control bus** The circuit along which control signals are transmitted.

**Control unit** The part of the IBM PC that receives and decodes instructions from a program in main memory, and then signals the appropriate units to execute the instructions.

**CPU** Central processing unit.

**CRT** Cathode ray tube.

**Cursor** The symbol on the display screen that indicates the position in which the next character will appear.

## D

**Data** Computer information such as numbers, letters, or special symbols.

**Data bus** The collection of wires or traces that carry the 8-bit data word from one location to another in your IBM PC computer.

**Diagnostic** An action or program that detects and isolates malfunctions or failures in computer hardware or software.

**DIN** A standard for computer equipment; the Deutsche Industrie Norm.

**DIP** Dual in-line package

**Direct memory access** A method for transferring data directly to and from main memory, bypassing the CPU.

**Disk** The magnetic medium on which computer data is stored.

**Disk operating system** A disk drive controller program.

**Display** The device on which visual information is displayed on a screen. The monitor in your IBM PC.

**DMA** Direct memory access.

**DOS** Disk operating system.

**Driver** A short subroutine or program that controls the I/O interaction between two devices (e.g., between the disk drives and the computer's CPU).

**Dual in-line package** The most common type of integrated circuit chip package, having two parallel rows of seven pins each.

## E

**Erasable programmable read-only memory** A type of ROM that can be erased and reprogrammed by applying a specified voltage to a certain pin on the chip.

**EPROM** Erasable programmable read-only memory.

## F

**Firmware** Programs that are stored in hardware, such as ROM.

**Flip-flop** An electronic device that maintains a value of 1 or 0 until acted on by a signal on a certain input pin.

## H

**Hardware** The physical components of a computer system. The computer itself, the printer, the monitor display unit, and so on.

**Head** The electromagnetic device that transfers data to and from your disks.

**Hertz** A unit of frequency; one cycle per second.

**Hexadecimal** The numbering system based on 16 digits, in which the values above 9 become A, B, C, D, E, and F. Each hexadecimal number can be represented as a 4-bit code.

## I

**IC** Integrated circuit, see chip.

**Initialize** To set a storage location, counter, or variable, for example, to a starting value.

**Input/output** The process of entering information into the computer or of transferring data from the computer to the outside world; for example, disk drives, keyboard, and display unit are input/output devices.

**Interface** A boundary shared by two or more devices.

**I/O** Input/output.

## K

**K** Stands for *kilo*, and in computer jargon is equal to 1024. K is the symbol used to represent the size of memory in your computer. The term 64K actually means 65,536.

## L

**Location** A place in memory where information may be stored.

## M

**Main storage** The storage located in the computer for programs, along with their data, while they are executing. The main storage in the PC is the RAM memory.

**Memory** The hardware in or on which programs are stored. Memory can be RAM or ROM chips, magnetic disks, magnetic tape, or magnetic bubbles (in bubble memory).

**MHz** Megahertz; a frequency of 1 million cycles per second.

**Microprocessor** An integrated circuit device that executes coded instructions that are entered, integrated, or stored within the device.

**Modem** A device (Modulator-Demodulator) that converts digital information into tones so it can be transmitted and received over communications lines such as telephone lines.

**Monitor** 1. A high-resolution display unit that produces sharper images than a standard television display. 2. A special program that is stored permanently in ROM; it enables interaction between you and the computer.

**Motherboard** The large printed-circuit board (system board) in the computer on which most of the electronic devices are mounted. The motherboard is the primary or main board in the computer. All other interfaces receive control signals or information from the motherboard.

## N

**Noise** The electrical interference that distorts the transmission of data and results in errors in the data. Noise can be caused by the presence of an electrical field such as that generated by data busses or TV/radio in the vicinity of electrical signals.

**NOR** A logic gate whose output is a logic 0 if any input is a logic 1, and a logic 1 only if all inputs are logic 0.

## O

**Operating system** A collection of system programs that controls the operation of a computer system. It can also handle the interaction between parts of the computer system.

## P

**Peripheral** A device, often sold as part of the computer,

that is connected to the computer to enhance its operation. Examples of peripherals include disk drives, monitor display units, printers, and modems.

**Pin** Any of the leads on a device, such as a chip, that plug into a socket and connect it to a system.

**Pixel** A picture element. The smallest unit in a display. Usually, this is a dot on the screen.

**Port** A connection between the CPU and another device, such as main memory or an I/O device, which allows data to enter or leave the computer or to be transferred between the CPU and memory.

## R

**RAM** Random-access memory.

**Random-access memory** Memory that can be directly read from or written to by your IBM PC's CPU. This memory is lost once the computer is turned off.

**Read-only memory** A type of memory chip that can be read from but cannot be written to or altered. ROM provides permanent storage for program instructions.

**Resolution** The measure of sharpness of a display image.

**ROM** Read-only memory.

## S

**Serial** One after the other; sequential.

**Software** The programs that determine or control the actions of your computer.

**Spike** A short, high-energy burst of electrical energy that, if not bypassed (or shorted) to ground, can cause damage to electronic components.

**Surge** A temporary increase in electrical voltage lasting long enough for its effect to be noticed on a meter.

## T

**Transient** Brief fluctuations in voltage.

**Troubleshoot** To systematically locate a computer hardware failure. Software failures are found by systematic debugging.

## W

**Warm boot** The process of restarting the computer without reloading the operating system.

**Word** A grouping of binary information that represents a unique value or character. A word in the IBM PC can be an 8-bit data word, or byte, or it can be a 16-bit address word.



# Bibliography

---

- Anderson, Garry J. "Designer's Guide to the CMOS STD Bus." *Electronic Products*, November 17, 1983, pp. 81-87.
- Archibald, Dale. "The Making of the Magnetic Media for Micros." *Softalk*, February 1982, pp. 160-164.
- Babcoke, Carl. "Practical Information About Testing and Replacing Capacitors." *Electronic Servicing*, July 1970, pp. 28-37.
- Babcoke, Carl. "Quick Testing of Transistors." *Electronic Servicing*, November 1970, pp. 26-33.
- Babcoke, Carl. "Simple Servicing Tips." *Electronic Servicing & Technology*, July 1983, pp. 44-49.
- Baker, Alan, and Mielke, Neal. "Detecting Quality and Reliability Defects in EPROMs." *Electronic Test*, November 1983, pp. 56-62.
- Barden, William, Jr. "Getting Your Micro Repaired." *Popular Computing*, May 1983, pp. 54-58.
- Bausell, James. "Desoldering Components From High Density PCB's." *Electronics*, February 1984, pp. 97-101.
- Belt, Forest. "1-2-3-4 Servicing Simplifies Industrial Electronic Maintenance." *Electronic Servicing*, September 1979, pp. 21-27.
- Benyo, Richard. "Singing the Praises of Dustcovers." *Popular Computing*, April 1983, p. 165.
- Bethune, Robert W. "Getting Along With Cassette Storage." *Popular Computing*, June 1983, pp. 190-192.
- Bogges, Andrew L., and Brown, Fred A. "Components Update: Cooling Fans." *Electronic Engineering Times*, June 4, 1984, p. 49.
- Bohannon, George. "The ABCs of IBM Graphics." *Softalk*, February 1983, pp. 30-36.
- Boyd, Alan. "System Notebook." *Softalk*, January 1983, pp. 60-64.
- Boyd, Alan. "System Notebook." *Softalk*, February 1983, pp. 82-85.
- Boyd, Alan. "System Notebook." *Softalk*, March 1983, pp. 108-110.
- Bradley, D.J. *Assembly Language Programming for the IBM Personal Computer*. Englewood Cliffs, NJ: Prentice-Hall, 1984.
- Brawley, Harry E., Jr. "Keep Your Cool." *Call A.P.P.L.E.*, May 1982, pp. 57-61.
- Brunelle, Robert. "Meeting the New Radio Interference Standards." *Digital Design*, November 1982, pp. 36-38.
- Bulkeley, William M. "Originators of BASIC Computer Language Seek To Profit from Success of Their Work." *Wall Street Journal*, November 15, 1983, p. 38.
- Bullard, Bobbi. "Comparing the IBM PC and the TI PC." *Byte*, November 1983, pp. 232-242.
- Camenker, Brian. "The Making of the IBM PC." *Byte*, November 1983, pp. 254-256.
- "Choosing and Using the Proper Soldering Iron." *Electronic Servicing & Technology*, December 1981, pp. 36-39.
- Choudhury, Margaret A. "Heat Shows Its Colors for Testing." *Electronic Packaging & Production*, May 1983, pp. 120-121.
- Crosby, Mark L. "Singin' the Disk I/O Blues." *Apple Orchard*, Winter 1981/82, pp. 63-68.
- Cunningham, John E. "Troubleshooting Digital Equipment." *Electronic Servicing*, September 1980, pp. 18-21.
- Curran, Lawrence J., and Shuford, Richard S. "IBM's Estridge." *Byte*, November 1983, pp. 88-97.

- Dale, Alan. "1-2-3-4 Servicing." *Electronic Servicing*, December 1970, pp. 26-30.
- Dash, Glen. "Understanding EMI Test Methods Eases Product Acceptance." *EDN*, May 1983, pp. 183-192.
- Davis, Dwight B. "Diagnostics Improve as Computer Systems Proliferate." *Mini-Micro Systems*, August 1982, pp. 115-123.
- Davis, Dwight B. "Manufacturers Work Out Last RFI Kinks as Final FCC Deadline Approaches." *Mini-Micro Systems*, September 1983, pp. 127-138.
- Deavenport, Joe E. "EMI Susceptibility Testing of Computer Systems." *Computer Design*, March 1980, pp. 145-149.
- DeVoney, Chris. *IBM's Personal Computer*. Indianapolis, Indiana: Que Corporation, 1983.
- DeVore, John A. "To Solder Easily." *Circuits Manufacturing*, June 1984, pp. 62-70.
- Disk Operating System*. Boca Raton, FL: IBM Corporation, 1983.
- Earle, A. Scott. "Taking a Closer Look at the RGB Monitor." *PC Magazine*, April 3, 1984, pp. 145-154.
- Engel, George M. "Line Cleaner—A Construction Project." *In Cider*, August 1983, pp. 108-110.
- Fastie, Will. "The IBM Personal Computer." *Creative Computing*, December 1981, pp. 19-40.
- Fenichel, Lisa. "The Dishonorable Discharge." *Circuits Manufacturing*, June 1984, pp. 88-98.
- Field, Tim. "The IBM PC and the Intel 8087 Coprocessor." *Byte*, August 1983, pp. 331-374.
- Field, Tim. "Enhancing Screen Displays for the IBM PC." *Byte*, November 1983, pp. 99-116.
- Frank, Dr. Arthur L. "Survey: Eyestrain." *Government Computer News*, December 1983, pp. 26-30.
- Freedman, David H. "Designing the Right Enclosure." *Mini-Micro Systems*, August 1983, pp. 229-242.
- Friedman, Herb. "Choosing the Right Floppy Disk." *Computers and Programming*, September/October 1981, pp. 29-31, 70.
- Freitag, Walter D. "Lubricants for Separable Connectors." *IEEE Transactions on Parts, Hybrids, and Packaging*, March 1977, pp. 32.
- Gayler, Winston D. *The Apple II Circuit Description*. Indianapolis, Indiana: Howard W. Sams & Co., Inc., 1983.
- Glasco, David B. "Using IBM's Marvelous Keyboard." *Byte*, May 1983, pp. 402-415.
- Glinert-Cole, Susan. "Upgrading a PC to an 'Xtra T.'" *PC Tech Journal*, February 1984, pp. 75-82.
- Goldblatt, Robert C. "How Computers Can Test Their Own Memories." *Computer Design*, July 1976, pp. 125-129.
- Goodman, Robert. "An Ounce of Prevention." *Electronic Servicing & Technology*, May 1983, pp. 24-39.
- Goodman, Robert L. "Techniques for Repairing Intermittents." *Electronic Servicing*, July 1979, pp. 33-39.
- Grant, Glenn. "Blackout." *The Byte Buyer*, Vol. 1, No. 12, December 16, 1983, pp. 7-13.
- Grolle, Carl G. *Electronic Technician's Handbook of Time-Savers and Shortcuts*. West Nyack, New York: Parker Publishing Company, Inc., 1974.
- Halperin, Stephen A. "Guarding Against Electrostatic Discharge." *Mini-Micro Systems*, August 1983, pp. 257-258.
- Hancock, Earle. "A Man of Letters." *In Cider*, December 1983, pp. 172-174.
- Hancock, Earle. "Do-It-Yourself Disk Drive Repair." *In Cider*, November 1983, pp. 32-34.
- Harbatkin, Lisa. "Where Do You Go When the Lights Don't Glow." *PC Magazine*, October 1983, pp. 143-147.
- Harwood, Robert. "Diagnostic and Utility Software." *Personal Computing*, October 1981, pp. 47-54, 166-169.
- Henriques, Vico E. "Visual Display Unit Legislation: New Hurdle to Efficient Government." *Government Executive*, April 1983, pp. 47-48.
- Hogan, Thom. "We're Not in Kansas Anymore." *The Portable Companion*, June/July 1982, pp. 11-14.
- Howson, Hugh R. "POKEing Around in the IBM PC." *Byte*, November 1983, pp. 121-131.
- Hunter, David. "The Roots of DOS." *Softalk*, March 1983, pp. 12-15.
- Illowsky, Dan, and Abrash, Michael. "Up, Down, Right, Left & Check." *PC Tech Journal*, February 1984, pp. 93-116.
- Jesson, Joseph E. "Smart Keyboards Help Eliminate Entry Errors." *Computer Design*, October 1982, pp. 137-142.
- Kaminer, David A. "What To Do When Your System Crashes." *Popular Computing*, April 1983, pp. 154-156.
- Kear, Fred W. "Board Warp: Causes and Prevention." *Circuits Manufacturing*, December 1983, pp. 95-98.
- Kotelly, George V. "Video Display Terminals: Help or Hazard?." *Mini-Micro Systems*, November 1983, p. 7.
- Lafore, Robert. *Assembly Language Primer for the IBM PC*. San Rafael, California: Plume/Waite, 1984.
- Lancaster, Don. *CMOS Cookbook*. Indianapolis, Indiana: Howard W. Sams & Co., Inc., 1977.
- Lemons, Phil. "The IBM Personal Computer First Impressions." *Byte*, October 1981, pp. 27-34.
- Lemons, Wayne. "Streamlined Tests for Transistors." *Electronic Servicing*, August 1977, pp. 34-39.
- Lerner, Eric J. "The Drive to Regulate Electromagnetic Fields." *IEEE Spectrum*, March 1984, pp. 63-70.
- Lewis, Gordon. "Disks, Drives, and Dirt." *Pro/Files*, September/October 1983, pp. 59-61.
- Lieberman, David. "Data Input Alternatives." *Electronic Products*, June 6, 1983, pp. 47-55.
- Lieberman, David. "The Clean Connection." *Nibble*, Vol.2, No.8, 1981, pp. 159-165.
- Little, M. Andre. "System Security." *In Cider*, December 1983, pp. 117-121.
- Little, Tom. "Ins and Outs." *Call A.P.P.L.E.*, June 1982, pp. 24-35.
- Little, Tom. "Ins and Outs." *Call A.P.P.L.E.*, July 1982, pp. 19-26.
- Littlefield, Patti. "What to Try Before Taking Your Microcomputer Into the Repair Department." *Educational Computer Magazine*, May/June 1983, pp. 73.
- Machrone, Bill. "How Boca Does It." *PC Magazine*, August 1983, pp. 111-115.
- Machrone, Bill. "User-to-User." *PC Magazine*, August 1983, pp. 565-566.
- Mann, Timothy J. "Disk Cleaner." *In Cider*, October 1983, pp. 166-168.
- Mardiguan, Michael, and White, Donald R. J. "Electrostatic Discharge, What It Is and How to Control It." *Electronic Products*, September 30, 1983, pp. 111-115.
- Margolin, Bob. "Video Display Terminals and Vision." *Com-*

- puters & Electronics, July 1984, pp. 56-59.
- Margolis, Art. *Troubleshooting & Repairing Personal Computers*. Blue Ridge Summit, Pennsylvania: Tab Books, Inc., 1983.
- May, Larry. "Choosing a Keyboard Technology." *Electronic Products*, September 30, 1983, pp. 91-96.
- McCain, John. "Spikes: Pesky Voltage Transients and How to Minimize Their Effects." *Byte*, November 1977, pp. 54-56.
- McCann, Scott. "Using a Switch-type Joystick on the IBM PC." *PC Tech Journal*, May 1984, p. 195.
- McClain, Larry. "Servicing Your System: Be Prepared." *Personal Computing*, September 1982, pp. 50-55, 148-154.
- McDermott, Jim. "EMI Shielding and Protective Components." *EDN*, September 5, 1979, pp. 165-176.
- McMullen, Barbare E., and McMullen, John F. "How Blue Can You Get?" *PC Magazine*, April 3, 1984, pp. 112-113.
- Miastkowski, Stan. "A Close Look at the IBM Personal Computer." *Popular Computing*, December 1981, pp. 52-57.
- Miller, Beth. "Microsystem Reliability Testing." *Electronic Test*, November 1983, pp. 48-54.
- Milner, Edward J. "Fast Memory Test Checks Individual Bits." *EDN*, October 13, 1983, pp. 222-229.
- Morgan, Chris. "IBM's Personal Computer." *Byte*, July 1981, pp. 6-10.
- Morgan, Christopher L. *Bluebook of Assembly Routines for the IBM PC*. San Rafael, California: New American Library, 1984.
- Naus, Herb. "Quiet Solutions for Military EMI/RFI Problems." *Circuits Manufacturing*, May 1984, pp. 41-44.
- "Need for EMI/RFI Shielding Spurs Use of Conductive Plastics." *Electronic Packaging & Production*, February 1984, p. 240.
- Norton, Peter. *Inside the IBM PC*. Bowie, MD: Robert J. Brady Company, 1983.
- Norton, Peter. "Snooping in ROM: The Software Interrupt." *Softalk*, February 1983, pp. 87-89.
- Norton, Peter. "Snooping in ROM: The Computer Musician." *Softalk*, March 1983, pp. 79-81.
- Norton, Peter. "Snooping in ROM: Which Version Did You Get?" *Softalk*, January 1983, pp. 86-88.
- Pearlman, Dara. "Coping With Static Electricity." *Popular Computing*, January 1984, pp. 150-155.
- Pingry, Julie. "The Expanding Realm of the IBM PC." *Digital Design*, February 1984, pp. 80-88.
- Poole, Lon. "Under the Hood of the PC." *PC Magazine*, September 1982, pp. 50-58.
- Quinn, G.C. "ESK Damage Today: Potentially More Destructive and Costly." *Electronics Test*, April 1984, pp. 94-104.
- Radding, Alan. "When Your Computer Breaks Down." *Popular Computing*, May 1983, pp. 196-198.
- Rampil, Ira. "A Floppy Disk Tutorial." *Byte*, December 1977, pp. 24-45.
- Rechsteiner, Emil B. "Keeping Power Clean and Steady." *Mini-Micro Systems*, August 1983, pp. 245-252.
- Riccio, Ronald. "How to Avoid Damage When Repairing PC Boards." *Electronic Servicing & Technology*, February 1983, pp. 38-42.
- Rich, Alan. "Understanding EMI-Type Noise." *Electronics Test*, May 1983, pp. 34-46.
- Robinson, J. B. *Modern Digital Troubleshooting*. Redmond, Washington: Data I/O Corporation, 1983.
- Rosch, Winn L. "High-Resolution Color Monitors." *PC Magazine*, June 1983, pp. 247-258.
- Santoni, Andy. "Probes and Test Cells Simplify EMI Testing." *EDN*, September 5, 1979, pp. 51-54.
- Sargent, Murray, III, and Shoemaker, Richard L. *The IBM Personal Computer from the Inside Out*. Menlo Park, CA: Addison-Wesley Publishing Company, 1984.
- Schatz, Gerald S. "Video Terminals Do Not Threaten Vision, Concludes National Research Council." *The IEEE Institute*. September 1983, pp. 1, 5.
- Schilling, Robert, Jr. "Hardware Diagnostics for the Home." *Popular Computing*, August 1983, pp. 204-210.
- Scovern, John L. "No Corrosion with Antistat." *Circuits Manufacturing*, January 1983, pp. 51-53.
- Shafer, Kurt. "Diverse UPS Technologies Provide Design Alternatives." *Digital Design*, June 1983, pp. 81-96.
- Shaffer, Richard A. "Electronic Interference Rises Causing Havoc in Many Fields." *Wall Street Journal*, November 18, 1983, p. 31.
- Sloop, Joe. "Troubleshooting Logic Systems Logically." *Electronic Servicing & Technology*, July 1983, pp. 26-37.
- Socha, John. "The Monochrome/Color Switch." *Softalk*, February 1983, pp. 31-33.
- Somerson, Paul. "Goblins, Gremlins and Glitches." *PC Magazine*, October 1983, pp. 111-129.
- Somerson, Paul. "User-to-User." *PC Magazine*, June 12, 1984, pp. 434-437.
- Snyder, E. J. "Engineering for EMI Compliance." *Mini-Micro Systems*, August 1983, pp. 254-255.
- Snyder, Harry L. "Visual Ergonomics and VDT Standards." *Digital Design*, February 1983, pp. 24-34.
- Technical Reference. Boca Raton, FL: IBM Corporation, 1983.
- Updegraff, Stephen W. "Better Than Gold—Substrate Coating Surpasses Gold in Hi-Rel Connectors." *Circuits Manufacturing*, December 1983, pp. 54-59.
- Van Leeuwen, Case J. "ESD Control Program: A Case History." *Electronics*, February 1984, pp. 58-61.
- Victor, Jesse. "Low Noise Topologies, Innovative Designs To Be Spotlit at Powercon 9." *EDN*, June 9, 1982, pp. 75-84.
- Weghorn, Frank. "Testers Address Segmented Disk Drive Market." *Electronics Products*, October 24, 1983, pp. 67-71.
- Whitaker, Lewis A. "Maintenance Alternatives for Personal Computers." *Byte*, June 1982, pp. 452-459.
- Wiles, James P., and Stewart, George. "What Happens When the Lights Go Out?" *Popular Computing*, August 1982, pp. 97-102.
- Williams, Gregg. "A Closer Look at the IBM Personal Computer." *Byte*, January 1982, pp. 36-68.
- "Wohl Talks About Peanuts and Other PCs." *Government Computer News*, December 1983, p. 5.
- Zachmann, Mark. "PC Tutor." *PC Magazine*, June 1983, pp. 65-83.
- Zachmann, Mark. "PC Tutor." *PC Magazine*, July 1983, pp. 69-74.
- Zachmann, Mark. "PC Tutor." *PC Magazine*, October 1983, pp. 577-585.
- Zachmann, Mark. "PC Tutor." *PC Magazine*, May 29, 1984, pp. 393-397.



# Index

## A

Arithmetic logic unit (ALU), 25, 191  
ASCII character set, 18, 40, 50, 191  
code chart, 190

## B

BASIC. See Cassette BASIC  
Boot-up routine, 54-55, 191  
cold boot, 54-55, 192  
failures. See Start-up failures  
warm boot, 55, 193  
Bus structure, 36-39, 191  
address bus, 37, 38-39, 391  
control bus, 38, 39, 192  
data bus, 37, 38, 39, 192  
PC bus, 39  
62-pin system bus, 39  
system bus, 39

## C

Cable connection failures, 65  
Capacitor failures, 63, 169-170  
aging process, 169  
capacitance measuring, 173  
dielectric oxide, dissolving, 169  
electrolyte insulator, 169  
open circuit, 169  
plate short, 169  
power surge, 169-170  
replacing capacitors, 63, 173  
temperature changes, 170  
testing capacitors, 172-173

Capacitors, 61-62  
anode, 169  
capacitor (cap) value identification, 61-62  
cathode, 169  
ceramic film, 61  
color-band values, 62  
description, 169  
dielectric layer, 169  
electrolytic, 61, 169  
failures. See Capacitor failures  
farads, 61  
film, 169  
function, 61  
polarity markings, 62  
tantalum, 61  
temperature-dependence values, 62  
tolerance values, 62  
variable, 61  
Cassette BASIC, 18, 21, 55  
dynamically relocatable program, 29  
interpreted language, 55  
ROM address allocation, 33  
Cassette recorder, 44-45  
circular cable connection, 44  
computer connection, 19  
jumper pin setting, 44  
programmable peripheral interface, 45  
Cassette recorder failures, 130-134  
data, can't write, 132-134  
data, won't read, 130-132  
Cassette tape storage, 22-23  
archival storage, 23  
Cathode ray tube. See CRT  
Central processing unit, 20, 27-32, 192  
address lines, 29  
bus controller, 29  
data transfer, 29

functions, 26-27  
Intel 8088, 21, 26, 28-29  
replacement parts, 71  
support chips, 29-32  
Chapter summaries, 14-15  
Chip failures, 63  
asphyxiation, 65  
bent/broken pins, 64  
cleaning, 149  
corrosion prevention, 148, 149  
dust, 137  
Easter egg test approach, 172  
fan-in/fan-out, 171  
floating, 171  
heating/cooling, 172  
high-voltage stress, 63, 169  
loose chips, 68  
metal migration, 168-169  
microvolt measuring, 172  
open connections, 63, 168  
open connections testing, 171  
piggybacking, 172  
power-cycling environments, 63, 169  
proper handling, 64, 73  
removing chips, 69  
replacing chips, 69-70  
shorts, 63, 169  
shorts testing, 170-171  
solder splashes, 64  
thermal stress, 63, 168  
wear-out failure, 63, 169  
Chips, 20, 59-61, 192  
description, 168  
failures. See Chip failures  
information chart, 182-183  
location scheme, 27  
manufacturer's device code markings,

60-61  
 manufacturer's logo markings, 59-60  
 manufacturer's type number markings, 60-61  
 pin numbering system, 59  
 pin 1, identification, 59  
 sizes, 21, 59  
 special chips, 21  
 transistor-transistor-logic (TTL) chips, 170  
**Circuit board.** See Motherboard  
**Clock generator (8284),** 21, 29-30, 192  
 basic clock signals, 30  
 clock timing signal, 29  
 oscillator signal, 29  
 power ready signals, 29  
**Color/graphics adapter card,** 22, 42-44  
 ASCII character set, 42  
 attribute code, 42  
 character production, 42  
 composite video output, 42  
 high-resolution graphics, 22, 42  
 light pen connection, 42  
 low-resolution graphics, 22, 42, 43  
 medium-resolution graphics, 22, 42, 43  
 radio-frequency (RF) modulator output, 42  
 RAM, 42  
 red-green-blue (RGB) output, 42  
 ROM, 42  
 synchronization signals, 42  
**Color/graphics monitor failures,** 106-121  
 bad characters displayed, 114-118  
 bad color, 118-120  
 no color, 118-120  
 no display, 106-109  
 no graphics, 120-121  
 no hi-res text, 120-121  
 no horizontal synchronization, 112-113  
 no lo-res text, 120-121  
 no text, graphics work, 113-114  
 no vertical synchronization, 110-112  
**Compiled-language programs,** 55  
**Component failures,** 63  
**Component recognition,** 58  
**Components.** See specific components  
**Configuration changes record sheet,** 187  
**Connector slots.** See Expansion slots  
**Control unit,** 25, 26, 192  
**Corrosion,** 148-149  
 atmospheric corrosion, 148  
 direct oxidation, 148  
 galvanic corrosion, 148-149  
 gold-plated connectors, 149  
 high temperatures, 149  
 prevention, 149  
**CPU.** See Central processing unit  
**CRT,** 64, 192  
 body strain, 16  
 eyestrain, 159-160  
 light radiation, 159  
 x-radiation, 159  
 See also Display monitor  
**Crystals,** 62  
 function, 62  
 oscillation frequency, 62

**D**

**Diodes,** 62  
 description, 170  
 digital multimeter (DMM) testing, 173-174  
 diode effect (DE), 174  
 failures, 63, 170  
 function, 62

identifying, 62  
 replacement, 63  
 DIP, 32, 61, 176  
**Disk drive,** 17, 18, 23, 45-48  
 computer connection, 20, 23  
 data transfer, 46-47  
 direct memory access (DMA) controller, 46-47  
 disassembly, 155-156  
 disk controller card, 45-46  
 hard disk maintenance, 158  
 modification, 47  
 multifunction boards, 47-48  
 preventive maintenance, 152-158  
**Disk drive failures,** 63-64  
 alignment, 157-158  
 disk drive speed tests, 155  
 disk speed program, 156  
 drive rotation speed, 64  
 drives can't be accessed, 91-93  
 head-cleaning, 152-155  
 head-cleaning timesheet, 155  
 magnetism, 149  
 neither drive will read, 84-87  
 neither drive will write, 89-91  
 one drive won't read, 81-84  
 one drive won't write, 87-89  
 read/write head alignment, 64, 157  
 tracking check, 157  
 tuning lamp, 156-157  
**Diskette.** See Disks  
**Disk failures,** 149-152  
 disk life extension checklist, 151  
 dust, 138, 150  
 magnetic oxide coating, 150  
 magnetism, 149  
 oxide layer build-up, 150-151  
 proper handling, 72  
 smoke, 150  
 storage envelopes, 150  
 thermal stress, 136  
**Disks,** 23, 45-46, 192  
 description, 46, 152  
 disk life, 150  
 preventive maintenance, 150-152  
 sounds, 152  
 using second side, 151-152  
**Display monitor,** 17, 19, 192  
 cleaning, 138-139  
 color/graphics adapter. See Color/graphics adapter card  
 color signal adjustment, 62  
 computer connection, 19, 20  
 monochrome adapter. See Monochrome adapter card  
 radio frequency (RF) modulator, 19, 22, 42  
**Display monitor failures,** 64  
 dust, 137  
 repairing, 64, 134  
 safety precautions, 72  
 See also Monochrome monitor failures;  
 Color/graphics monitor failures  
**Dynamically relocatable programs,** 29

**E**

**Equipment history record sheet,** 186-187  
**Error codes,** 77  
**Expansion slots,** 20-21, 26  
 adapter card, 20, 26  
 open architecture, 20

**F**

**Failures.** See specific component; specific problem; repair-generated failures  
**Firmware.** See ROM  
**Floppy disks.** See Disks  
**FORTLAN,** 55

**G**

**Game control adapter,** 51-52  
 circuitry, 51-52  
 HIGH output check, 52  
 joystick connection, 51  
 loop polling, 52  
 pushbutton connection, 51  
 value of resistance, 52

**H**

**Hardware troubleshooting approach,** 65, 161  
**Hexadecimal-to-decimal conversion chart,** 190

**I**

**IBM-Easy troubleshooting approach,** 58, 67-71, 161  
**IBM PC,** 17-24  
 binary operations, 57, 59  
 connections, 19  
 data sheet, 181-182  
 digital machine, 57  
 interrupt-driven machine, 21, 30  
 life-cycle cost, 135  
 operational life, 179  
 structure, 18-19  
 system configuration, 23-24  
 third-party components, 17-18  
**Input unit,** 25, 26  
 expansion slots, 18  
 Input/Output devices, 26  
 memory-mapped I/O, 39  
**Integrated circuits.** See Chips  
**Interference.** See Noise interference

**K**

**Keyboard,** 18-19, 48-50  
 ASCII character set, 50  
 automatic repeat, 19  
 character storage space, 19  
 computer connection, 19  
 chord keying, 48  
 DIN specification, 19  
 disassembly, 185-186  
 electronic circuits, 19, 48  
 function keys, 18  
 key redefinition, 19  
 keys, 19, 48  
 numeric key pad, 18  
 phantom switch condition, 49  
 position adjustment, 19  
 reassembly, 186  
 scan code, 48-49  
 special keys, 18-19, 48  
 switch matrix, 48  
 system interrupt, 49-50  
**Keyboard failures,** 121-125

computer locks up, keyboard entries  
won't work, 93-95  
keyboard stays in lower case, 124-125  
keyboard stays in upper case, 124-125  
keyboard won't respond, 121-123  
keys won't work, 124  
liquid spillage, 64, 73  
wrong character printed, 121-123

## L

Light pen connecting, 42  
Light pen failure, 128-130  
Liquid crystals (LC), 158-159  
recording-temperature-limit liquid crystal  
(RTL-LC), 159  
temperature-limited liquid crystal (TL-LC),  
158-159

## M

Magnetism, 149-150  
magnetic flux, 149  
preventing harmful effects of, 150  
sources, 149  
Main logic board. See Motherboard  
Main memory. See RAM  
Mass storage, 22-23, 26  
See also specific storage units  
Memory, 20, 25, 193  
address space, 32  
dual in-line package switches (DIP), 32  
expansion, 20, 32  
memory design, 32  
See also RAM, ROM  
Metal oxide semiconductor (MOS) chip  
handling, 73  
Microprocessor. See Central processing unit  
Minidiskettes. See Disks  
Modem, 26, 193  
Monitor. See Display monitor  
Monochrome adapter card, 22, 39-42  
ASCII character set, 40  
character production, 39  
computer connection, 40  
CRT controller (6845), 40  
functions, 39  
operating description, 40-42  
Monochrome monitor failures, 95-106  
bad characters displayed, 101-104  
no display, 95-98  
no hi-res display, 104-106  
no horizontal synchronization, 100-101  
no lo-res display, 104-106  
no vertical synchronization, 98-99  
Motherboard, 18, 20, 193  
chips, 20  
disassembly, 184  
hairline cracks, 171  
hot spots, 172  
mounted devices, 58-59  
mounted devices, replacement, 186  
RAM location, 36  
reassembly, 185  
repairing, 178

## N

Noise interference, 69, 139-145, 193  
acoustic noise, 139

capacitance values, 140  
conducted RFI, 139  
crosstalk, 140  
description, 139  
electromagnetic interference (EMI), 139  
electromagnetic radiation (EMR), 139  
electrostatic discharge (ESD), 139, 140, 149  
glitches, 140, 143  
high-voltage transients, 141  
internal EMI, 139, 140  
magnetic fields, 141  
power-line noise, 140  
radiated RFI, 139  
radio frequency interference (RFI), 139  
sources, 140-141  
spikes, 140  
transient EMI, 139, 140  
triboelectric series chart, 143-144  
Noise interference countermeasures, 69,  
141-145  
acoustic pads, 141  
audible noise, 141  
bonding originals, 141  
component design improvements, 141  
conducted EMI, 142  
electromagnetic interference (EMI),  
141-143  
electrostatic discharge (ESD), 143-144  
FCC EMI requirements, 142  
ferrite-shield beads, 142  
fiber-optic cables/connectors, 143  
filtering, 141  
filter pins, 142  
intermittent failures repair, 69  
metal enclosures, 142  
radiated EMI, 142  
radio frequency interference (RFI), 144-145  
shielded cables, 142  
shielding, 141, 145  
wiring improvements, 141  
Numeric data processor chip (8087), 21

## O

Operating system, 17, 56, 193  
Operational log sheet, 187  
Output unit, 25, 26

## P

PC-DOS operating system, 56  
Peripherals. See Input/Output devices;  
specific device  
Power-line problems, 145-148  
blackouts, 145  
brownouts, 145  
brown-up, 145  
transients, 146, 193  
Power-line problems, prevention of,  
146-148  
auxiliary power source, 146  
backup power supply selection checklist,  
147-148  
continuous-service UPS, 147  
filters, 146  
forward-transfer UPS, 147  
isolators, 146  
metal oxide varistor (MOV), 146  
motor generators, 147  
power-line conditioners, 146, 147  
regulators, 146

reverse-transfer UPS, 147  
uninterruptible power supply (UPS),  
146-147  
Power supply. See Switching power supply  
Preventive maintenance, 135-160  
annual routines, 188  
cold temperatures, 137  
daily routines, 188  
dust, 137-138  
dust countermeasures, 138-139  
fans, 137  
heat countermeasures, 136-137  
monthly routines, 188  
static electricity, 137  
thermal stress, 136  
thermal wipeout, 136  
weekly routines, 188  
Printer, 17, 19  
audible noise, 141  
dust problems, 137  
Processor. See Central processing unit  
Programmable interrupt controller (8259),  
21, 30-31  
hardware-interrupt, 31  
interrupt controller, 31  
interrupt-request-line inputs, 31  
interrupt signals, 30  
Programmable interval timer (8253 PIT), 21,  
32  
Programmable peripheral interface (8255  
PPI), 21, 31-32  
cassette operating, 45  
functions, 32  
handshaking lines, 31

## R

RAM, 21-22, 25, 34, 193  
addressing error, 66  
bank addressing scheme, 34-35  
expansion, 22, 34  
motherboard address location, 36  
parity checking, 32, 35-36  
storage error, 66  
Random access memory. See RAM  
Read-only memory. See ROM  
Relays, 62  
Repair-generated failures, 64  
Repair parts, 71  
electronic parts stores, 71  
IBM service center, 71  
spare parts checklist, 178-179  
trade magazines, 71  
Repair service checklist, 72  
Resistors, 61  
color-band values, 61  
cylindrical wire-wound device, 61  
DIP resistor networks, 61  
failures, 63, 170  
functions, 61  
ohms, 61  
replacement, 63  
resistor network, 61  
SIP resistor networks, 61  
ROM, 21, 25-26, 193  
address allocations, 32-33  
basic input/output system (BIOS), 21, 33  
direct memory access controller (8237  
DMA), 21  
self-tests, 33  
RUN failures. See Disk drive failures;  
Keyboard failures

Rust. See Corrosion

## S

Safety precautions, 72-73  
 component handling, 73  
 disk handling, 72  
 display monitor chassis, 72  
 liquids, 73  
 logic clip, 163  
 oxidation, 149  
 power cycling, 72-73  
 power off, 58, 68, 72, 149  
 power strip, 73  
 soldering, 76  
 summary list, 189  
 switching power supply, 72  
 Software, 17, 193  
 debugging, 167  
 See also specific type  
 Software troubleshooting approach, 65-67, 161  
 Butterfield test, 67  
 diagnostic software tests, 65-66  
 dual-address test, 66-67  
 memory diagnostic tests, 66-67  
 rotating-bit test, 66  
 self-diagnostic capability, 67  
 sequential numbers test, 66  
 simple store-and-read test, 66  
 sum test, 67  
 walking-bit test, 66  
 Soldering, 175-178  
 capacitors, 173  
 chips, 70-71, 176  
 circuit testing, 178  
 DIP extractor, 176  
 flux, 177  
 melting temperature, 176  
 motherboards, 178, 186

removing solder, 175-176  
 safety precautions, 76  
 soldering tip, 177  
 solder sucker, 175  
 technique, 176-177  
 tinning, 177  
 tip cleaning, 177  
 wave soldering, 176  
 Solid-state components, 63  
 Speaker, 22, 50-51  
 failures, 125-127  
 Start-up failures, 76-81  
 beep indicators, 76  
 error displays, 78  
 I/O error codes, 77-78  
 no power light, nothing works, nothing on screen, 78-79  
 power light on, nothing works, nothing on screen, 79-81  
 system error codes, 77  
 Static. See Noise interference  
 Switching power supply, 18, 22, 52-53  
 description, 53  
 disassembly, 184-185  
 reassembly, 185  
 repairing, 53, 134  
 safety precautions, 72  
 voltages, 52-53  
 System board. See Motherboard  
 System description record sheet, 187  
 System monitor, 55  
 System unit, 18, 19-22  
 disassembly, 19-20  
 reassembly, 185

## T

Telephone interference, 145  
 Television interference, 141  
 Thermal imaging, 158

Tools, 161-168

advancements, 162-163  
 current tracer, 165  
 digital multimeter (DMM), 162, 173  
 digital voltmeter (DVM), 71, 162  
 DIP extractor, 176  
 IC tester, 166  
 logic analyzers, 71, 167  
 logic clip, 71, 163  
 logic probe, 71, 163-164, 171  
 logic pulser, 163-164, 171  
 ohmmeter, 173, 174  
 oscilloscope, 71, 166-167  
 oscilloscope bandwidth, 166  
 recommended equipment, 178  
 resistance test, 71  
 signature analyzer, 71, 167-168  
 vacuum-tube-voltmeter (VTVM), 162, 171  
 voltage test, 71  
 volt-ohm-milliammeter (VOM), 161-162, 171  
 Transistors, 62  
 failures, 63, 170  
 functions, 62, 170, 174  
 identifying, 62  
 ohmmeter testing, 174-175  
 replacement, 63  
 Troubleshooting, basic, 57-58  
 hardware approach, 65  
 IBM-Easy approach, 65-67  
 safety precautions, 72-73  
 software approach, 67-71  
 steps, 58  
 Troubleshooting index, 76

## V

Video display. See Display monitor  
 Von Neumann machine, 59